



This is a digital copy of a book that was preserved for generations on library shelves before it was carefully scanned by Google as part of a project to make the world's books discoverable online.

It has survived long enough for the copyright to expire and the book to enter the public domain. A public domain book is one that was never subject to copyright or whose legal copyright term has expired. Whether a book is in the public domain may vary country to country. Public domain books are our gateways to the past, representing a wealth of history, culture and knowledge that's often difficult to discover.

Marks, notations and other marginalia present in the original volume will appear in this file - a reminder of this book's long journey from the publisher to a library and finally to you.

Usage guidelines

Google is proud to partner with libraries to digitize public domain materials and make them widely accessible. Public domain books belong to the public and we are merely their custodians. Nevertheless, this work is expensive, so in order to keep providing this resource, we have taken steps to prevent abuse by commercial parties, including placing technical restrictions on automated querying.

We also ask that you:

- + *Make non-commercial use of the files* We designed Google Book Search for use by individuals, and we request that you use these files for personal, non-commercial purposes.
- + *Refrain from automated querying* Do not send automated queries of any sort to Google's system: If you are conducting research on machine translation, optical character recognition or other areas where access to a large amount of text is helpful, please contact us. We encourage the use of public domain materials for these purposes and may be able to help.
- + *Maintain attribution* The Google "watermark" you see on each file is essential for informing people about this project and helping them find additional materials through Google Book Search. Please do not remove it.
- + *Keep it legal* Whatever your use, remember that you are responsible for ensuring that what you are doing is legal. Do not assume that just because we believe a book is in the public domain for users in the United States, that the work is also in the public domain for users in other countries. Whether a book is still in copyright varies from country to country, and we can't offer guidance on whether any specific use of any specific book is allowed. Please do not assume that a book's appearance in Google Book Search means it can be used in any manner anywhere in the world. Copyright infringement liability can be quite severe.

About Google Book Search

Google's mission is to organize the world's information and to make it universally accessible and useful. Google Book Search helps readers discover the world's books while helping authors and publishers reach new audiences. You can search through the full text of this book on the web at <http://books.google.com/>

NYPL RESEARCH LIBRARIES



3 3433 08184133 4

The
Gordon Lester Ford
Collection
Presented by his Sons
Worthington Chauncey Ford
and
Paul Leicester Ford
to the
New York Public Library

THE NEW YORK
PUBLIC LIBRARY.
ASTOR, LENOX AND
TILDEN FOUNDATIONS.



Tramway 761 D

THE 100th U.S. INFANTRY, CAMP BURNETT, CALIF. (REAR VIEW)

THE 100th U.S. INFANTRY

Gordon L. Ford

N I N E V E H

AND

ITS REMAINS :

WITH AN ACCOUNT OF A VISIT TO THE CHALDÆAN
CHRISTIANS OF KURDISTAN, AND THE YEZIDIS,
OR DEVIL-WORSHIPPERS; AND AN INQUIRY
INTO THE MANNERS AND ARTS OF
THE ANCIENT ASSYRIANS.

BY AUSTEN HENRY LAYARD, ESQ., D.C.L.



"She saw men portrayed upon the wall, the images of the Chaldeans portrayed with vermilion,

"Girded with girdles upon their loins, exceeding in dyed attire upon their heads, all of them princes to look to, after the manner of the Babylonians of Chaldeæ, the land of their nativity."

ESKIZEL, xxiii. 14, 15.

IN TWO VOLUMES.—VOL. II.

NEW-YORK:
GEORGE P. PUTNAM, 155 BROADWAY.
1849.

THE NEW YORK
PUBLIC LIBRARY
160925
ASTOR, LENOX AND
TILDEN FOUNDATIONS.
1899

WROY W. B.
CLUB
WATER

CONTENTS:

CHAPTER XI.

Death of Tahyar Pasha—Excavations carried on—Discoveries in the Northwest Palace—New Chambers and Bas-reliefs—Ivory Ornaments and Cartouches with Hieroglyphics—Painted Chambers—Pottery—Discovery of upper Chambers—Paintings on the Walls—Pavement Slabs—Discoveries in the Centre of the Mound—Tombs containing Vases and Ornaments—Their Egyptian Character—Bas-reliefs collected together—Description of the Sculptures—Further Discoveries in the Southwest Edifice—Crouching Sphinxes—Sculptures—A Description of the Bas-reliefs—Small Figures in unbaked Clay—A Beam of Wood—Discovery of more Tombs in the Southeast corner—of Chambers beneath them—of an arched or vaulted Room—Discoveries in various parts of the Mound Page 9

CHAPTER XII.

Excavations undertaken at Kalah Sherghat—Departure for the Ruins—Senidij—The Bitumen Pits—Abd'rubbou—My Reception—Reach the Ruins—Fears of the Workmen—Discovery of a sitting Figure—Arab Encampment—Arab Life—Excavations in the Mound—Discovery of Tombs—Remains of Building—Description of the Mounds—Return to Nimroud 41

CHAPTER XIII.

System of Irrigation adopted by the ancient Assyrians—Want of Rain—Fears for the Crops—Preparations for the removal of a winged Bull and winged Lion—Construction of a Cart—Surprise of the Natives—Discovery of a Bas-relief—of a Drain—Lowering of the winged Bull—Its removal from the Ruins—Excitement of the Arabs—Rejoicings in the Village—The Bull dragged down to the

CONTENTS.

River—The Removal of the Lion—Discontent amongst the Arabs—They leave the Ruins—Rafts prepared for the Transport of the Sculptures to Busrah—The Lion and Bull placed upon them—Their Departure from Nimroud—Return of the Arabs—Excavations commenced in the Pyramid—Conclusion of the Excavations at Nimroud—General Description of the Ruins Page 59

CHAPTER XIV.

Excavations planned at Kouyunjik—Leave Nimroud—Remove to Mosul—Discovery of a Building in Kouyunjik—Bas-reliefs—General Description of the Sculptures—Excavations carried on by Mr. Ross—His Discoveries—Bas-reliefs—A sculptured Slab and Sarcophagus—Preparations for my Return to Constantinople—Leave Mosul 94

PART II.

CHAPTER I.

Materials for the History of Assyria—Comparative Dates of Monuments—Assyrian Writing—The Cuneiform—Its Varieties—Assyrian Records—Writing Materials—Monumental Records—Bricks and Tiles—Progress in Deciphering—Assyrian Monuments of various Periods—The Ivory Ornaments—Cartouches—Connection between Assyria and Egypt—Historical Evidence of Period of Ninus—The Assyrian Dynasties—The Tombs at Nimroud—Antiquity of Nineveh 123

CHAPTER II.

Semitic Origin of the Assyrians—Identification of the Site of Nineveh—Dimensions of the City—Architecture of the Assyrians—Their first Cities—Building Materials—Sun-dried Bricks—Alabaster—Painted Walls—The Roof and Ceiling—Knowledge of Vaulting and the Arch—Pavement and Drains—Description of an Assyrian Palace—The sculptured and pictorial Records—The Nature of the Buildings discovered in Assyria—Exterior Architecture—Private Houses—Absence of the Column—Walls of the Cities—Their Towers and Gateways 187

CHAPTER III.

The Arts amongst the Assyrians—Their Origin—Connection between Assyrian and Greek Art—The Assyrian Origin of Persian Art—Its Passage into Asia Minor—The Lycian Sculptures—Various Greek Ornaments and Forms borrowed from Assyria—Taste of Assyrians displayed in Embroideries, Arms, and personal Or-

naments—in domestic Furniture—in Vessels of Gold and Silver—Paintings—Ezekiel's Description of painted Bas-reliefs—Colors used by the Assyrians—Their Dyes—Materials for Sculpture—Alabaster or Mosul Marble—Limestone and Basalt—Knowledge of Mechanics—The Pulley—Mode of Transport of Blocks of Stone Page 291

CHAPTER IV.

Costume of the Assyrian Kings—Their Arms—The Eunuchs—Their Dress—The History of Parsondes—Officers of State—The Warriors—Their Armor—Their Costume—Spearmen—Archers—Helmets—Arms—Slingers—Shields—Regular Troops—Chariots—Harness and Caparison of the Horses—Cavalry—Horses 248

CHAPTER V.

Military System of the Assyrians—Magnitude of their Armies—Their Pomp—Sieges—The Battering-ram and other Engines of War—Mode of Defence—Scaling the Walls—Sack of a City—Treatment of the Captives and of the City—Knowledge of Ship-building—Earliest Vessels—Later Vessels, as represented at Khorsabad and Kouyunjik—Enemies of the Assyrians, distinguished by their Dress—Armenians and Parthians or Persians—Captives and Tribute from India—The Arabs—The Jews—The Babylonians—The Phœnicians—Northern Nations—Identification of Enemies of the Assyrians with those of the Egyptians 278

CHAPTER VI.

Private Life of the Assyrians—Public Festivals—Music—Manufactures—Embroideries and Carpets—Metals—Gold and Silver—Iron and Copper—Ivory—Glass—Agriculture—Domestic Animals—Wild Animals—The Lion—The Wild Bull—The Ibex—Hunting—Parks or Paradises—Wild Animals brought as Tribute—The Bactrian Camel, Elephant, and Rhinoceros—Monkeys and Apes—Birds—Fish—Trees 311

CHAPTER VII.

Religion of the Assyrians—Distinction between earliest and latest Periods—Sabæanism and Worship of the Heavenly Bodies—Identity of Assyrian and Persian Systems of Fire-worship—The Chaldæans—Religious Emblems in the Sculp-

CONTENTS.

ures—The winged Figure in the Circle—Baal or Belus—Hera, Venus, or Astarte—Rhea—Nisroch or Eagle-headed God—The Gryphon—Winged Bulls and Lions—The Sphinx—Mythological Figures—Symbolic Figures of Ezekiel—Oannes or the Man-fish—Fire-worship—The Magi—Flowers and sacred Emblems—Influence of Religion on public and private Life—Mode of Burial—Tomb of Ninus—Death and Tomb of Sardanapalus—Conclusion Page 333

LIST OF PLATES, WOODCUTS, AND PLANS,

IN VOLUME II.

Procession of the Bull beneath the Mound of Nimroud.	<i>Frontispiece.</i>
The King. (N. W. Palace, Nimroud.)	Facing page 13
Plan 4. Upper Chambers on the West Side of the Mound. (Nimroud.)	Page 19
Enemy asking Quarter of Assyrian Horsemen. (S. W. Palace, Nimroud.)	Page 29
Part of a Bas-relief showing a Pulley, and a Warrior cutting a Bucket from the Rope.	Page 32
Plan 5. Excavations in the South-east Corner of the Mound. (Nimroud.)	Page 37
Sitting Figure in Basalt, from Kalah Sherghat.	Page 47
Warriors hunting the Lion. (N. W. Palace, Nimroud.)	Facing page 66
Plan of excavated Ruins at Kouyunjik.	Facing page 101
The King in his Chariot returning from Battle. (Kouyunjik.)	Facing page 110
Wedge or Arrow-head on an Altar. (From a Stone in the Bibliotheque Nationale at Paris.)	Page 144
Scribes writing down the Number of Heads of the Slain, and the Amount of the Spoil. (Kouyunjik.)	Page 147
Figures, and Cartouche with Hieroglyphics, on an Ivory Panel from the N. W. Palace, Nimroud.	Facing page 166
The Egyptian Goddess Ken (from a Tablet in the British Museum); and Assyrian Deity, ? the Astarte of the Assyrians and the Ken of the Egyptians (from a Rock Tablet at Malthaiyah, near Mosul).	Page 169
Forms of Pottery found in the Tombs above the Ruins at Nimroud	Page 174
A House. (Kouyunjik.) The Interior of a Tent. (Kouyunjik.)	Page 214
A Temple, or Fishing Pavilion, supported by Proto-Ionic Columns, and standing in a River or artificial Lake. (Khorsabad.)	Page 216

Head of winged Bull. (Khorsabad and Kouyunjik.)	Head of winged Monster.	
(Persepolis.)		Page 223
Fragment of a Lycian Monument in the British Museum.		Page 229
Bas-relief from a Monument from Xanthus, in the British Museum.		Page 230
Assyrian Ornament. (Nimroud.)	Greek Honeysuckle Ornaments.	Page 231
Ornament on a Lath at Allahabad.	Ornament. (N. W. Palace, Nimroud.)	Page 232
Ornaments. (N. W. Palace, Nimroud.)		Page 228
Sacred Tree. (N. W. Palace, Nimroud.)		Page 233
Ear-ring. (N. W. Palace, Nimroud.)	Assyrian Ear-rings. (Khorsabad.)	Hilt of a Sword. (Khorsabad.)
	End of a Sword Sheath. (N. W. Palace, Nimroud.)	Page 234
Handles of three Daggers carried in the Girdle. (N. W. Palace, Nimroud.)		Page 228
A Throne or Stool. (N. W. Palace, Nimroud.)		Page 234
A Stool. (Khorsabad.)	An Arm-chair. (Khorsabad.)	Page 234
A Couch or Table. (Khorsabad.)	A Footstool supported by Lion's Paws. (N. W. Palace, Nimroud.)	Page 236
A Table. (N. W. Palace, Nimroud.)	Cup with Handle. (Khorsabad.)	Page 234
Altars, or Stands for Jars. (N. W. Palace, Nimroud.)		Page 236
Drinking Cup. (Khorsabad.)	Vase from a Bas-relief. (Khorsabad.)	Page 236
Basket or Vessel carried by winged Figures. (Khorsabad.)		Page 236
Head-dress of the King. (N. W. Palace, Nimroud.)	Head-dress of the King. (Kouyunjik.)	Page 236
A Sandal. (N. W. Palace, Nimroud.)	A Sandal. (Khorsabad.)	Page 236
A Spearman. (Kouyunjik.)		Page 261
Greaves or Gaiters worn by Warriors. (Khorsabad.)		Page 236
An Archer. (Kouyunjik.)		Page 261
Helmets. (Centre Palace, Nimroud.)		Page 236
Circular Helmet. (Centre Palace, Nimroud.)		Page 236
Assyrian Warriors fighting with the Enemy. An Eagle is carrying away the entrails of the Slain. (Centre Palace, Nimroud.)		Page 261
Slinger. (Kouyunjik.)		Page 261
Assyrian Warrior with Spear and Shield. (Kouyunjik.)		Page 261
Warriors forming a Phalanx before the Walls of a besieged City. (Kouyunjik.)		Page 268
Assyrian Warriors in a Chariot. (S. W. Ruins, Nimroud; but originally brought from the N. W. Palace.)		Facing page 269
Groom leading Horses. (From a Fragment discovered at Khorsabad, and now in the British Museum.)		Page 268
Assyrian Chariot of the later Period. (S. W. Ruins, Nimroud.)		Facing page 273
Horsemen — one drawing the Bow, the other holding the Reins of both Horses. (N. W. Palace, Nimroud.)		Page 274
Head-dress of a riding Horse. (Kouyunjik.)		Page 275
A Horseman pursued by Assyrian Warriors. (Kouyunjik.)	(From a Cast in the	

British Museum.)	Facing page 276
Battering-ram, with movable Tower containing Warriors. (N. W. Palace, Nimroud.)	Page 274
Bas-relief representing Warriors before a besieged City. A Battering-ram drawn up to the Walls, and Captives impaled. (Centre Palace Nimroud.)	Page 283
Warriors forcing Stones out of the lower Part of the Wall of a besieged City. (S. W. Palace, Nimroud.)	Page 284
A City taken by Assault, and the Inhabitants led away Captive. (Kouyunjik.)	Facing page 285
Manacles for the Feet. (Khorsabad and Kouyunjik.)	Manacles for the Hands.
(Khorsabad and Kouyunjik.)	Page 261
A pair of Scales for weighing the Spoil. (Khorsabad.)	Page 284
A Boat carrying a Chariot, and Men floating on inflated Skins.	Page 284
A Ship. (Khorsabad.)	Page 293
Ship. (Kouyunjik.)	Page 295
Coin of uncertain Origin, conjectured to belong to a City on the Syrian Coast during the Persian Occupation.	Page 284
Castle of a maritime People, probably the Tyrians. (Kouyunjik.)	Page 284
A Galley. (Kouyunjik.)	Page 297
Flying Warrior discharging an Arrow. (N. W. Palace, Nimroud.)	Page 297
A walled City standing on a River or on the Sea. (Centre Palace, Nimroud.)	Page 303
Captive Women in a Cart drawn by Oxen. (Centre Palace, Nimroud.)	Page 284
Assyrian Horsemen pursuing a Man, probably an Arab, on a Camel. (Centre Ruins, Nimroud.)	Facing page 301
Chariot carried away by the Assyrians, amongst other Spoil, from a captured City. (Khorsabad.)	Page 303
Enemies of the Assyrians discharging their Arrows behind them. (Kouyunjik.)	Page 297
Bactrian or two-humped Camels. (Obelisk, Nimroud.)	Page 330
Elephant, the Ouran Outan (?), the Hounuman, or small Indian Monkey (?). (Obelisk, Nimroud.)	Page 330
The Bull, the Rhinoceros, and the Chikara, or large Indian Antelope (?). (Obelisk, Nimroud.)	Page 330
The Brub, or great Indian Monkey (?), and the Wanderoo, or maned Ape (?). (Obelisk, Nimroud.)	Page 330
Sacred Emblems suspended round the Neck of the King. (N. W. Palace, Nimroud.)	Page 303
Emblems of the Deity. (N. W. Palace, Nimroud.)	Page 340
Winged Circle. (Pterium.)	Page 303
Idols carried in Procession by Assyrian Warriors. (S. W. Ruins, Nimroud.)	Facing page 342
Hera or the Assyrian Venus. (From a Rock Tablet near the ancient Pterium.)	Facing page 346
A Gryphon. (N. W. Palace, Nimroud.)	Page 351

Winged Horse. (N. W. Palace, Nimroud.)	Page 351
Eagle-headed Figure. (S. W. Palace, Nimroud.)	Warriors carrying a Bird.
(Centre Palace, Nimroud.)	Page 351
Lion-headed Figure. (S. W. Palace, Nimroud.)	Page 354
The Fish God. (Khorsabad.)	Page 351
An Altar, resembling that on the Sassanian Coins. (Khorsabad.)	Page 351
Fire-Altar. (Khorsabad.)	Page 351
Fire-Altar and Sacrifice. (Kouyunjik.)	Page 354
Altar, or Tripod. (From Khorsabad.)	Page 354

NINEVEH

AND

ITS REMAINS.

CHAPTER XI.

As I was drawing one morning at the mound, Ibrahim Agha came to me, with his eyes full of tears, and announced the death of Tayhar Pasha. The Cawass had followed the fortunes of the late Governor of Mosul almost since childhood, and was looked upon as a member of his family. Like other Turks of his class, he had been devoted to the service of his patron, and was treated more like a companion than a servant. In no country in the world are ties of this nature more close than in Turkey; nowhere does there exist a better feeling between the master and the servant, and the master and the slave.

I was much grieved at the sudden death of Tahyar; for he was a man of gentle and kindly manners, just and considerate in his government, and of considerable information and learning for a Turk. I felt a kind of affection for him. The cause of his death showed his integrity. His troops had plundered a friendly tribe, falsely represented to him as rebellious by his principal officers, who were anxious to have an opportunity of enriching themselves with the spoil. When he

learnt the particulars of the affair, and that the tribe, so far from being hostile, were peaceably pasturing their flocks on the banks of the Khabour, he exclaimed, "You have destroyed my house" (*i. e.* its honor), and, without speaking again, died of a broken heart. He was buried in the courtyard of the principal mosque at Mardin. A simple but elegant tomb, surrounded by flowers and evergreens, was raised over his remains; and an Arabic inscription records the virtues and probable reward of one of the most honest and amiable men that it has been my lot, in a life of some experience amongst men of various kinds, to meet. I visited his monument on my return to Constantinople. From the lofty terrace, where it stands, the eye wanders over the vast plains of Mesopotamia, stretching to the Euphrates—in spring one great meadow, covered with the tents and flocks of innumerable tribes.

The Kiayah, or chief secretary, was chosen Governor of the province by the council, until the Porte could name a new Pasha, or take other steps for the administration of affairs. Essad Pasha, who had lately been at Beyrout, was at length appointed to succeed Tahyar, and soon after reached his Pashalic. These changes did not affect my proceedings. Armed with my firman I was able to defy the machinations of the Cadi and the Ulema, who did not cease their endeavors to throw obstacles in my way.

After the celebration of Christmas I returned to Nimroud, and the excavations were again carried on with activity.

I should weary the reader, were I to describe, step by step, the progress of the work, and the discoveries gradually made in various parts of the great mound. The labors of one day resembled those of the preceding; but it would be difficult to convey to others an idea of the excitement which was produced by the constant discovery of objects of the highest interest. A mere journal of my proceedings would afford but little amusement, and I should have to repeat, over and over again, the same details, and should probably be led into a repetition of the same reflections. I prefer, therefore, describing

at once the results of my labors during the first three months of the year; and I will endeavor to explain, as concisely as possible, the extent of the operations, and the nature of the buildings uncovered. I must necessarily make frequent reference to the plans; as without the assistance they afford, it would be difficult to convey an accurate idea of the form of the edifices and the position of the chambers.

The northwest palace was naturally the most interesting portion of the ruins, and to it were principally directed my researches. I had satisfied myself beyond a doubt that it was the most ancient building yet explored in Assyria. Not having been exposed to a conflagration like other edifices, the sculptures, bas-reliefs, and inscriptions, which it contained, were still admirably preserved.

When the excavations were resumed after Christmas, eight chambers had been discovered. There were now so many outlets and entrances, that I had no trouble in finding new rooms and halls—one chamber leading into another. By the end of the month of April I had explored almost the whole building; and had opened twenty-eight chambers cased with alabaster slabs. Although many new objects of sculpture of considerable interest and importance were found in them, still the principal part of the edifice seems to have been that to the north. Chambers B and G contained the most remarkable bas-reliefs; they represented the deeds of the king in war and in the chase, his triumphant return, and the celebration of religious ceremonies. The best artists had evidently been employed upon them; and they excelled all those that had yet been discovered, in the elegance and finish of the ornaments, and in the knowledge of art displayed in the grouping of the figures. The walls of the other chambers were either occupied by a series of winged figures, separated by the sacred tree,—the figures resembling one another in every respect,—or the usual inscription alone was carved upon the slabs.

It will be perceived that a certain symmetry was, to some extent, observed in the plan of the building; particularly in

the arrangement of the chambers to the East ; those marked I and L corresponding in form and size, and both leading into small rooms, which do not communicate with any other part of the edifice. Each slab, however, in chamber L, is occupied by only one figure,—a gigantic winged divinity, or priest,—and is not divided into two compartments, as in chamber I. But it is remarkable that on the slab No. 20, there is a figure differing from all the rest, and corresponding with the figures found on the lower part of the slab No. 16, of chamber I. It is that of a winged female deity or priestess, bearing a garland in one hand, and raising the other as if in some act of adoration. Around her neck are suspended, in the form of a double necklace, the star-shaped ornaments already described.* In this chamber also occur niches similarly placed to those in I. In front of the female figure, and forming part of the pavement, was a slab with a hole through the centre. On raising it I found an earthen pipe, about eight inches in diameter and two feet in length, communicating with a drain running underneath, the whole being lined and cemented with bitumen. One or two fragments of ivory were also found in this room.

In chamber H all the groups were similar—representing the king holding a cup in one hand and his bow in the other, attended by two winged figures with garlands round their heads. The sculptures in chamber G, as I have already observed, were chiefly remarkable for the variety and elegance of the ornaments on the robes of the king and his attendants. Amongst them were groups of figures similar to those represented on the walls of the palace, such as the king slaying the lion, and hunting the bull ; winged figures before the sacred tree ; religious emblems ; various animals and elaborate scroll work ; all furnishing not only beautiful designs, but important illustrations of the religion of the Assyrians.

The entrance *d* to this chamber was formed by two gigantic

* See page 279, Vol. I. This figure has been moved, and is amongst the sculptures which have been secured for the British Museum.

THE NEW YORK
PUBLIC LIBRARY.
ASTOR, LENOX AND
TILDEN FOUNDATIONS.



THE KING, (N. W. FACED, NINEP0001)

eagle-headed winged figures, of considerable beauty and finish. One of them was moved, and will be brought to England. In the chamber beyond, were repeated the winged divinities or priests, with the emblematic tree; except on slab 6, which had the king holding a bow in one hand, and two arrows in the other.

The four sculptures in the chamber, or rather passage, P (Nos. 1, 2, 3, and 4), were remarkable for the beauty of the ornaments and details, and their careful finish. They all represented winged figures, either holding a mace, a fir-cone, or some religious emblem. On their dresses, however, were a variety of groups and designs—lion hunts, bull hunts, winged animals, and many groups of winged figures. Amongst the last was a curious representation of the Assyrian Venus, Mylitta or Astarte, in an indecent posture which indicated the peculiar nature of her worship.

On each of the slabs forming the narrow passage *a*, leading from the chamber P, were two winged figures back to back. They were well designed and carefully executed. Beyond them, on slabs 2, 3, and 4, of chamber S, was the king between two eunuchs. The figure of the king, one of the most carefully sculptured and best preserved in the palace, has been removed, and will be brought to England. He is represented with one hand on the hilt of his sword, the other being supported by a long wand, or staff.

On the remaining slabs of chamber S the winged figures were repeated. Some carried flowers of various shapes, whilst others had the usual fir-cone, and square basket, or utensil.

Three sides alone of the great hall Y, were found entire. From its size it is probable that it was not roofed in, but was an open court. It appears to have been nearly square; but the western wall has been completely destroyed; the slabs having perhaps been carried away to be used in the construction of the southwest palace. Three entrances are still standing. The one at *b*, formed by a pair of winged lions—those at *e* and *f*, by winged bulls. There was probably a fourth en-

trance on the western side, formed by a pair of lions, to correspond with that on the eastern ; but I found no remains of it, although some might perhaps be discovered on a more careful examination. The removal of the slabs, which formed the western wall, has caused a depression in the mound ; and consequently, if any large sculptures, such as the winged lions, had been left, when the slabs adjoining them were taken away, they would probably have been exposed to decay ; and the upper part, remaining longest uncovered, would have been completely destroyed.

Behind the great hall Y, to the south, were a cluster of chambers leading one into another. Their proportions were small. V and W did not contain sculptures. T was surrounded by the usual winged figures ; one of its entrances (*a*) being formed by two gigantic priests or divinities, with garlands round their heads, holding in one hand an ear of corn, and in the other an ibex, or mountain goat.

The chamber V is remarkable for the discovery, near the entrance *a*, of a number of ivory ornaments of considerable beauty and interest. These ivories, when uncovered, adhered so firmly to the soil, and were in so forward a state of decomposition, that I had the greatest difficulty in extracting them, even in fragments. I spent hours lying on the ground, separating them, with a penknife, from the rubbish by which they were surrounded. Those who saw them when they first reached this country, will be aware of the difficulty of releasing them from the hardened mass in which they were embedded. The ivory separated itself in flakes. Even the falling away of the earth was sufficient to reduce it almost to powder. This will account for the condition of the specimens which have been placed in the British Museum. With all the care that I could devote to the collection of the fragments, many were lost, or remained unperceived, in the immense heap of rubbish under which they were buried. Since they have been in England, they have been admirably restored and cleaned. The gelatinous matter, by which the particles forming

the ivory are kept together, had, from the decay of centuries, been completely exhausted. By an ingenious process it has been restored, and the ornaments, which on their discovery fell to pieces almost upon mere exposure to the air, have regained the appearance and consistency of recent ivory, and may be handled without risk of injury.

The important evidence as to the epoch of the destruction of the building, furnished by these ivories, will be alluded to in another place. I will here merely describe them. The most interesting are the remains of two small tablets, one nearly entire, the other much injured. Upon them are represented two sitting figures, holding in one hand the Egyptian sceptre or symbol of power. Between them is a cartouche, containing a name or words in hieroglyphics, and surmounted by a feather or plume, such as is found in monuments of the eighteenth, and subsequent dynasties of Egypt. The chairs on which the figures are seated, the robes of the figures themselves, the hieroglyphics in the cartouche, and the feather above it, were enamelled with a blue substance let into the ivory, and the whole ground of the tablet, as well as the cartouche and part of the figures, was originally gilded—remains of the gold leaf still adhering to them. The forms, and style of art, have a purely Egyptian character; although there are certain peculiarities in the execution, and mode of treatment, that would seem to mark the work of a foreign, perhaps an Assyrian, artist. The same peculiarities—the same anomalies—characterize all the other objects discovered. Several small heads in frames, supported by pillars or pedestals, most elegant in design and elaborate in execution, show not only a considerable acquaintance with art, but an intimate knowledge of the method of working in ivory. Found with them were oblong tablets, upon which are sculptured, with great delicacy, standing figures, with one hand elevated, and holding in the other a stem or staff, surmounted by a flower or ornament resembling the Egyptian lotus. Scattered about were fragments of winged sphinxes, the head of a lion of singular beauty, but which un-

fortunately fell to pieces, human heads, hands, legs, and feet, bulls, flowers, and scroll-work. In all these specimens the spirit of the design and the delicacy of the workmanship are equally to be admired.*

On the two slabs forming the entrance to chamber U, were two remarkable inscriptions, cut above those which invariably occur on the slabs of this palace. They contained the name of the king who founded Khorsabad, and they had evidently been placed there long after the lower inscriptions (from which they differ in the forms of many characters) had been cut. They may have been carved to celebrate the reopening, or the restoration, of the building.

In all the chambers to the south of the great hall Y, were found copper vessels of peculiar shape; but they fell to pieces almost immediately on exposure to the air, and I was unable to preserve one of them entire.

Beyond the entrance *b*, as far as chamber S, the alabaster slabs ceased altogether; and I was, for some time, at a loss to account for the manner in which the building had been con-

* I add Mr. Birch's description of the most important of the ivory ornaments—that containing the cartouche. "The first of these panels, which is the most complete, measures nine inches long by six inches high. The cartouche is placed vertically in the centre, surmounted by a solar disk, gilded, flanked by two ostrich feathers, which are inlaid with narrow horizontal strips of opaque blue glass, probably imitations of lapis-lazuli, and with some few bars in green. The area of the cartouche is gilded, and the hieroglyphics are incised, and inlaid with blue glass. At each side is a divinity, beardless, wearing the long hair-dress called *namms*, also inlaid with blue, and draped in linen garments, enveloping the whole of the form, with a border of inlaid blue ovals. The seats on which they sit are the usual Egyptian throne, the side decorated with scales alternately of blue and opaque green pastes, inlaid into the ivory, and intended to imitate lapis-lazuli and felspar. At the lower corner, in a compartment, in gilded ivory on a blue back-ground, is a symbol of life. Each divinity holds in one hand a *tam* or *kukupha* sceptre, and holds up the other with the palm turned towards the cartouche. No name is attached to either of these figures, which are probably intended for deities of an inferior rank, such as the Persian Ixjeds. Like all the Egyptian figures, they are unbearded; but their drapery is not that of Egyptian females." (*Trans. of the Royal Society of Literature*, New Series.) For a detailed description of all the ivory fragments discovered, see Appendix.

tinued. The pavement of baked bricks was still carried on, and it was evident that the edifice did not end here. It was some time before I discovered that I was now digging into chambers formed by walls of sun-dried bricks, over which a thin coating of plaster had been laid. They had been painted with figures and ornaments; but the colors had faded so completely, that scarcely any of the subjects or designs could be traced. It required the greatest care to separate the rubbish from the walls, without destroying, at the same time, the plaster to which it adhered. I seldom succeeded in uncovering even a small portion of the paintings, as the plaster fell from the walls in flakes, notwithstanding all my efforts to preserve it. I was able to draw a few of the ornaments, in which the colors chiefly distinguishable were red, blue, black, and white. The subjects of the paintings appeared to be generally processions, in which the king was represented followed by his eunuchs and attendant warriors. The figures were merely in outline, in black upon a blue ground, and I was unable to distinguish any other color. In design they resembled the sculptures—exhibiting the same features, and the same peculiar treatment in the draperies and attitudes.

As the means at my disposal did not warrant any outlay in making more experiments, without the promise of the discovery of something to carry away, I felt myself compelled, much against my inclination, to abandon the excavations in this part of the mound, after uncovering portions of two chambers. The doorway, which united them, was paved with one large slab, ornamented with flowers and scroll-work. The flooring was of baked bricks.

I found, by opening trenches behind chambers I and L, that similar painted rooms existed in other parts of the mound. The palace did not, therefore, only contain chambers formed by slabs of alabaster, but had other apartments, extending considerably beyond the limits shown in the plan. How far, I could not ascertain.

It may be mentioned that on the slabs 1 and 2, and those

opposite, of chamber Z, were sculptured small winged figures, —two, one above the other, on each. On removing No. 2, I found behind it, imbedded in the wall of sun-dried bricks, a small earthen bowl, or cup, of baked clay of a dark red color. This, consequently, is the most ancient specimen of pottery hitherto discovered in Assyria; for, from its position behind the slab, it is evident that it must have been placed there at the time of the building of the edifice.* Between the bulls and lions, forming the entrances in different parts of the palace, were invariably found a large collection of baked bricks, elaborately painted with figures of animals, and flowers, and with cuneiform characters. It is remarkable, that on the back of these bricks, or on one of the sides not colored, are rude designs, in black paint or ink, of men and animals, and marks having the appearance of numbers. They appear to have been built into a wall above the sculptures. That they belonged to this edifice is proved by the name of the king which is painted upon them.†

Whilst excavating above the southern chambers of this palace, I found, in the rubbish several feet above the walls, numerous vases of baked clay. In those that were preserved entire, human remains could be distinguished; but it was not until I had made further discoveries, that I learnt the nature and importance of these objects.

On the western side of the great mound, to the south of the palace in which the discoveries just described were made, there is a considerable elevation. The spot is marked *e* on plan 1. To examine the place, a trench was opened on a level with the platform. It was some time before I discovered that we were cutting into a kind of tower, or nest of upper chambers, constructed entirely of unbaked bricks; the walls being plastered, and elaborately painted. I explored three rooms, and part of a fourth, on the southern side of the building.

* It has been preserved, and will be placed in the British Museum.

† Many specimens have been secured, and will be deposited in the British Museum.

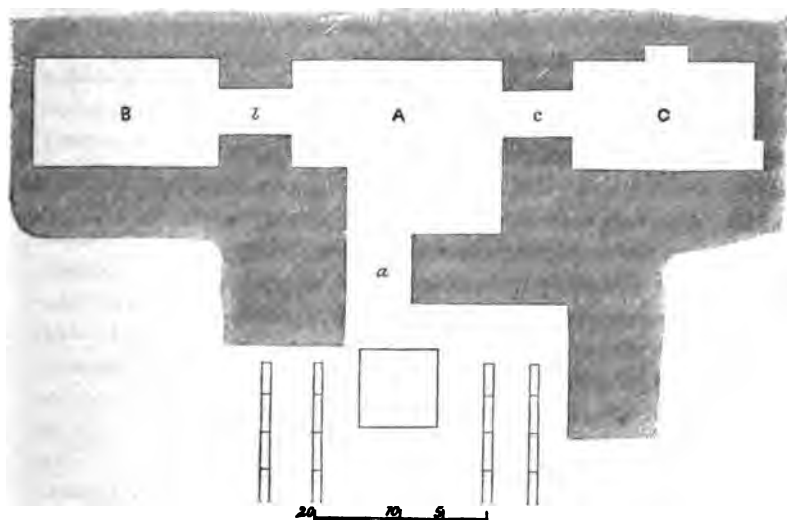

PLAN 4.—Upper Chambers on the West Side of the Mound. (Nimroud.)

It is probable that there were four similar groups of chambers, facing the four cardinal points. In front of the entrance *a*,* was a large square slab with slightly-raised edges, similar to those frequently found in the northwest palace. Parallel with it were two narrow pieces of alabaster, with a groove running down the centre, carefully cut and fitted together, which I can only compare to the rails of a railroad. I cannot form any conjecture as to their use. The rooms had been twice painted—two distinct coats of plaster being visible on the walls. The outer coating, when carefully detached, left the under; on which were painted ornaments differing from those above.

In the centre, and in one of the corners, of chamber C, were recesses, similar to those in some of the alabaster slabs in the northwest palace. No remains of plaster, or color,

* See plan 4.

could be traced upon the sun-dried bricks, forming the back of these recesses.

The painted ornaments were elaborate and graceful in design. The Assyrian bull was frequently portrayed, sometimes with wings, sometimes without. Above the animals were painted battlements, similar to those of castles, as represented in the sculptures. Below them, forming a kind of cornice, were squares and circles, tastefully arranged; and more elaborate combinations were not wanting. The colors found were blue, red, white, yellow, and black. I doubt whether any green was used in this building; the green on the under coating of plaster, being rather the result of the decomposition of the blue. The pale yellow of the ground, on which the designs were painted, resembles the tint on the walls of Egypt; but it is possible that white had changed to this color.

But the most important discovery, connected with these upper chambers, was that of the slabs forming the pavement of the two entrances *a* and *b*. Upon them were the names and titles of five kings, in genealogical succession; commencing with the father of the founder of the northwest palace, and ending with the grandson of the builder of the centre edifice. By this valuable record, I was able to verify the connection between the names already discovered, and to add two more to the list.*

I could not ascertain whether there were any chambers, or remains of buildings, beneath this upper edifice; or whether this was a tower constructed on the solid outer wall. A deep trench was opened on the eastern side of it,† and about twenty feet below the surface, a pavement of brick and several square slabs of alabaster were uncovered; but these remains did not throw any light upon the nature of the building above; nor were they sufficient to show that the northwest palace had been carried under these upper chambers. To the south of them there were no remains of building, the platform

* One of these slabs will be placed in the British Museum.

† At *d*, in plan 1.

of unbaked bricks being continued up to the level of the flooring of the chambers ; but there is reason to believe that this part of the mound is of a more recent date than that to the north of it, and was added at a subsequent period.

In the centre of the mound, to the north of the great winged bulls, I had in vain endeavored to find traces of building. Except the obelisk, two winged figures, and a few fragments of yellow limestone, which appeared to have formed part of a gigantic bull or lion, no remains of sculpture had yet been discovered. On excavating to the south, I found a well-formed tomb, built of bricks, and covered with a slab of alabaster. It was about five feet in length, and scarcely more than eighteen inches in breadth in the interior. On removing the lid, parts of a skeleton were exposed to view ; the skull and some of the larger bones were still entire ; but, on an attempt being made to move them, they crumbled into dust. With them were three earthen vessels. A vase of reddish clay, with a long narrow neck, stood in a dish of such delicate fabric, that I had great difficulty in removing it entire. Over the mouth of the vase was placed a bowl or cup, also of red clay. This pottery appears to have stood near the right shoulder of the body. In the dust, which had accumulated round the skeleton, were found beads and small ornaments belonging to a necklace. The beads are of opaque colored glass, agate, cornelian, and amethyst. A small crouching lion of lapis lazuli, pierced on the back, had been attached to the end of the necklace. The vases and ornaments are Egyptian in their character, being identical with similar remains found in the tombs of Egypt, and preserved in collections of antiquities from that country. With the beads was a cylinder, on which is represented the king in his chariot, hunting the wild bull, as in the bas-relief from the northwest palace. The surface of the cylinder has been so much worn and injured, that it is difficult to distinguish the figures upon it. A copper ornament resembling a modern seal, two bracelets of silver, and a pin for the hair were also discovered. I carefully collected and preserved

these interesting remains, which seemed to prove that the body had been that of a female.

On digging beyond this tomb, I found a second, similarly constructed, and of the same size. In it were two vases of highly glazed green pottery, elegant in shape, and in perfect preservation. Near them was a copper mirror, and a copper lustral spoon, all Egyptian in form.

Many other tombs were opened, containing vases, plates, mirrors, spoons, beads, and ornaments. Some of them were built of baked bricks, carefully joined, but without mortar; others were formed by large earthen sarcophagi, covered with an entire alabaster slab, similar to those discovered in the south-east corner of the mound, and already described.*

Having carefully collected and packed the contents of the tombs, I removed them and dug deeper into the mound. I was surprised to find, about *five feet beneath them*, the remains of a building. Walls of unbaked bricks could still be traced; but the slabs, with which they had been cased, were no longer in their places, being scattered about without order, and lying mostly with their faces on the flooring of unbaked bricks. Upon them, were both sculptures and inscriptions. Slab succeeded to slab; and when I had removed nearly twenty tombs, and cleared away the earth from a space of about fifty feet square, the ruins, which had been thus uncovered, presented a very singular appearance. Above one hundred slabs were exposed to view, packed in rows, one against the other, as slabs in a stonecutter's yard, or as the leaves of a gigantic book. Every slab was sculptured; and as they were placed in a regular series, according to the subjects upon them, it was evident that they had been moved, in the order in which they stood, from their original positions against the walls of sun-dried brick; and had been left as found preparatory to their removal elsewhere. That they were not thus arranged before being used in the building for which they had been originally sculp-

* See Vol. I. p. 285.

tured, was evident from the fact, proved beyond a doubt by repeated observation, that the Assyrians carved their slabs after, and not before, they were placed. Subjects were continued on adjoining slabs, figures and chariots being divided in the centre. There were places for the iron brackets, or dovetails. They had evidently been once filled, for I could still trace marks and stains left by the metal. To the south of the centre bulls were two gigantic figures, similar to those discovered to the north.*

These sculptures resembled, in many respects, some of the bas-reliefs found in the southwest palace, in which the sculptured face of the slab was turned, it will be remembered, towards the walls of unbaked bricks. It appeared, therefore, that the centre building had been destroyed, to supply materials for the construction of this edifice. But here were tombs *over* the ruins. The edifice had perished, and in the earth and rubbish accumulating above its remains, a people whose funeral vases and ornaments were identical in form and material with those found in the catacombs of Egypt, had buried their dead. What race, then, occupied the country after the destruction of the Assyrian palaces? At what period were these tombs made? What antiquity did their presence assign to the buildings beneath them? These are questions which I am yet unable to answer; and which must be left undecided, until the origin and age of the contents of the tombs can be satisfactorily determined.

The bas-reliefs differed considerably from those of the northwest palace, both in the character of the sculpture, and the treatment of the subjects; in the costumes of the figures, in the caparisons of the horses, and in the form of the chariots. The distinction was so great, that the short period elapsing between the reigns of a father and son could scarcely have given rise, except under extraordinary circumstances, to so considerable a change in all these points. As the centre bulls

* See Vol. I. p. 261.

were inscribed with the name of the son of the founder of the northwest building, it might be presumed that the ruins near them belong to the same period as the rest of the palace. However, this is liable to doubt. The bulls, as it has already been pointed out,* may have stood alone on the platform, and may have been placed long previous to the construction of an edifice. There were a few inscriptions accompanying the bas-reliefs, and they may hereafter serve to decide the question. On the greater number of slabs, however, the space between the bas-reliefs was left without any inscription.

The subjects principally recorded by the sculptures thus found collected together, with the exception of a few gigantic figures of the king and his attendant eunuchs, and of the winged priests or divinities, were battle-pieces and sieges. Some cities were represented as standing on a river, in the midst of groves of date-trees; others on mountains. Amongst the conquered people were warriors mounted on camels. It may be inferred, therefore, that a part of these sculptures were made to record the invasion or conquest of an Arab nation, or perhaps of a part of Babylonia; the inhabitants of the cities being assisted by auxiliaries, or allies from the neighboring desert. The conquered race, as in the bas-reliefs of the northwest palace, were generally without helmets or armor, their hair falling loosely on their shoulders. Some, however, were provided with helmets, which vary in shape from those worn by the conquerors.

A battering ram, differing in form from that seen in the earlier sculptures, was found on bas-reliefs representing sieges. They were unaccompanied by the moving tower; some were provided with two rams, the ends of which, instead of being broad and blunt, were pointed, and resembled the heads of spears.

On two slabs (occupied by one subject) were bas-reliefs of considerable interest. They have been sent to England, and

* Vol. I. p. 261.

represent the taking of a city, within the walls of which grew the palm and other trees. The place having been sacked, the conquerors are seen carrying away the spoil. Two eunuchs, standing near the gates, count, as they pass before them, the sheep, oxen, and other cattle driven away by the warriors, and write down the numbers with a pen upon rolls of paper or leather. In the lower part of the bas-relief, are two carts drawn by oxen. Two women and a child are in each. The women appear to be carrying away bags, containing provisions or valuable property, saved during the sack. Near the gates stand two battering rams, which, the city having been taken, are no longer at work. The subject is not ill-arranged, and the oxen drawing the cart are well designed.

On the fragment of a slab were found two gigantic horses' heads, well designed; but sculptured in very low relief, and greatly injured. I also discovered parts of a winged human-headed bull, the whole being in relief. I was able to preserve one of the heads.

Upon other slabs were the king seated on his throne, the sun, moon, and other religious symbols being placed above his head, and receiving prisoners with their arms bound behind them; eunuchs registering the heads of the enemy, laid at their feet by the conquering warriors; a procession of gods borne on the shoulders of men; and many other subjects.

The sides of all the slabs thus placed one against the other—the part which, in the event of their gradual covering up, would have been longest exposed—were worn away. It was, therefore, evident that they had not been buried by the same process as the sculptures in the northwest palace, the walls of which could not have been long exposed. If the edifice to which they originally belonged had been suddenly covered up, it must have been subsequently excavated. The slabs were then removed from their places, and arranged as they were found, preparatory to being used for other purposes, probably for the construction of the southwest palace. Not having been carried away, as that palace had not been finished, they

were left exposed, and were gradually covered by dust and rubbish. As the slabs stood on their sides, and not upright, all the bas-reliefs had suffered more or less injury. Many were completely destroyed, no traces of sculpture remaining upon them. The upper part of the slabs had not been the first injured; this proves that they were not exposed whilst standing in their original position, but subsequent to their removal.

Although on each slab the two bas-reliefs were divided by an unsculptured space, as in the northwest palace, in few instances, as I have already mentioned, were inscriptions cut upon it. It had been left blank; but whether intentionally, or because the building had never been completed, there were no means of ascertaining. The slabs, too, were much thinner than those used in other parts of the mound; and, as the dove-tailed and circular holes for metal braces on the top were cut in half, it is evident that they had been reduced in size after having been used. They had probably been sawn in two, the other half having been carried elsewhere. There were no inscriptions on the back, as is invariably the case in the northwest palace; and this is another proof that the slabs had been reduced after they had been placed. In fact, I have little doubt, from the appearance of these ruins, that the building to which the sculptures originally belonged had been suddenly buried, like that in the northwest corner of the mound; and that it had subsequently been uncovered, the materials being wanted for the construction, as I have conjectured, of the southwest palace. The slabs, not having been required, were left exposed, until they were reburied by a gradual accumulation of dust and rubbish. I could still trace the walls of unbaked bricks, forming the divisions of chambers in the old edifice.

To the east of the centre bulls I discovered the remains of several slabs, still standing in their proper position. The lower part alone remained, the upper having been completely destroyed. Upon them had been sculptured gigantic winged figures, carrying the usual square vessel, and a sacred flower

Several trenches were opened around these remains; but, with the exception of the sculptures just mentioned, and the fragments of a second winged bull of yellow limestone, I could find no traces of building in the centre of the mound.

I have described the singular appearance presented by the ruins in the southwest corner. Several parties of workmen were now engaged in exploring them. When all the walls still standing had been traced, and trenches opened in opposite directions, so that no remains of building could escape observation, I was equally at a loss to determine the position of the chambers, and the extent of the edifice.

It will be seen, by a reference to plan 2, that the only portion of the building sufficiently well preserved to give any idea of its original form, was one large hall curiously constructed. Leading into it were two entrances, formed by gigantic winged bulls and lions with human heads; and, in the centre, was a portal formed by a second pair of bulls. At entrance *a*, were a pair of lions with the crouching sphinxes between; at entrance *c*, a pair of bulls much injured, only the lower part being entire. A human head, belonging to one of them, was, however, discovered near the remains of the body; and as it was nearly entire, I sent it to Busrah. The second pair of bulls were at entrance *b*. They resembled the lions at entrance *a*, in having figures sculptured behind the body of the animal, and between the cap and the wings. Between them were a pair of double sphinxes—two sphinxes, resembling those already described, being united, and forming one pedestal. They had been greatly injured by fire, and the heads and all the sculptured portions of the figure had fallen to pieces.*

The lions and bulls were all sculptured out of a coarse gray limestone; the space between them was paved with small slabs of the same material. I have called all the space in-

* The remains of a small double sphinx of this kind had already been found in the rubbish at entrance *a*. See Vol. I. page 234.

closed by the walls *d*, *e*, *m*, *l*, *k*, and *j*, one hall ; although it is divided into four separate chambers by a thick partition in the centre. This partition appears to have been merely constructed to support the beams of the roof, and not to have been meant as a division between different rooms.

The hall narrows near the four corners, and in the narrowest part at each extremity were two low spherical stones, flattened at the top. I cannot account for their use. If they were bases of columns supporting the roof, why were they placed in the narrowest part of the hall ? No remains of pillars were found near them, and if any ever existed they must have been of wood. It appears more probable that these stones corresponded in some manner with the crouching sphinxes between the bulls and lions ; and were altars to receive sacrifices, or tables upon which vases or utensils were laid.

The whole of this hall was panelled with slabs brought from elsewhere ; the only sculptures, attributable to those who built it, being the gigantic lions and bulls, and the crouching sphinxes. The slabs were not all from the same edifice. Some, and by far the greater number, belonged to the northwest, others to the centre, palace. But there were many bas-reliefs which differed greatly, in the style of art, from the sculptures discovered in both those buildings. From whence they were obtained I was unable to determine ; whether from a palace of another period once existing at Nimroud, and still concealed in a part of the mound not explored, or from some ruin in the neighborhood.

All the walls had been exposed to fire ; the slabs were nearly reduced to lime, and were too much injured and cracked to bear removal. They were not all sculptured ; the bas-reliefs being scattered here and there ; and, as I have already observed, always when left entire, turned towards the wall of sun-dried brick. The earth had consequently to be removed by the workmen from both sides of the slabs.

I will proceed to describe the walls as they are marked on

the plan ; without a reference to which, the details and form of the ruins can scarcely be understood.

All the slabs in wall *a* were unsculptured, except Nos. 5 and 10. On the first were represented the walls of a castle, the king being within, seated on his throne, and receiving his vizir. Around him were his attendants, and above him a groom bringing corn to a horse tied to a manger. On the other slab was a horseman wearing a helmet with a curved crest, of which a sketch is given. He appears to be raising his hand in the act of asking for quarter, whilst his horse,



Enemy asking quarter of Assyrian horsemen. (S. W. Palace, Nimrod.)

pierced by the spears of two pursuing warriors, is rearing and plunging.* Both the slabs had been greatly injured.

No remains of sculpture could be traced on walls *b*, *c*, and *d*. Upon the faces of most of the slabs forming wall *e*, were the marks of a chisel, or of some metal instrument. The bas-reliefs had been carefully erased, the only part of the figures remaining being the feet, which would probably have been concealed by the pavement of the chamber. As the sculptured face of the slabs had been turned towards the chamber, and not to the wall of sun-dried brick, it is evident that the bas-reliefs had been purposely destroyed; the intention of the builders of the edifice being either to recarve the alabaster, or to reduce it to a smooth surface. The boots, and fringes on the lower part of the dresses of the erased figures, identified them with the sculptures in chambers D and E of the north-west palace (plan 3), from whence indeed they may have been brought, as the ravine to the north of that edifice must have been partly caused by the removal of a wall. On the slab adjoining entrance *e*, were two bas-reliefs, the upper (partly destroyed) representing warriors hewing down trees; the lower, a warrior on horseback hunting the wild bull. Both were too much injured to bear removal.

Only parts of walls *f* and *h* had been finished; many of the slabs not having been used, and still lying in the centre of the chamber. It was evident that they had not fallen after having been placed, for they were entire, having only suffered injury from fire; they were, moreover, arranged in rows with great regularity, and, in one or two instances, heaped one above the other. These prostrate slabs, therefore, furnished additional evidence that the building had been destroyed before its completion. In wall *f*, were the two sculptured slabs already described.† In wall *h*, there were bas-reliefs on Nos. 1, 2, and on the adjoining prostrate slab. In the upper compart-

* This sculpture will be placed in the British Museum.

† See Vol. I. page 55.

ment of No. 2, was represented the king, in his chariot, discharging an arrow against a charioteer, whose horses had already been wounded. Scattered about, were the bodies of the slain. The top of this bas-relief had been destroyed, and the slab so much injured, that it could not be moved. In the lower compartment were two kneeling archers, wearing the conical helmet, and a eunuch also discharging an arrow; behind them were several figures, probably prisoners, raising their hands. The draperies, and ornaments on both bas-reliefs were elegant and elaborate, resembling those on the opposite slab (No. 1, wall *f*), to which they appear originally to have been joined, forming part of the same subjects.

The corner stone (No. 1) was reversed; upon it was a figure with the conical cap, apparently made of bands of linen or felt, and already described as represented in the sculptures of chambers D and E (plan 3).* The upper part of the stone (or the lower part of the reversed figure) had been purposely destroyed, the marks of the chisel being visible. In this respect, and in its position, it resembled the opposite corner stone.

On the prostrate slab were two bas-reliefs. The upper was so much injured that the outlines of a chariot, and warriors on foot, could with difficulty be traced. The lower was the siege of a castle; a eunuch was represented discharging his arrows against warriors, without helmets, who manned the towers and walls. The besiegers were leading away prisoners, and carrying off the spoil. One high-capped warrior was seen cutting a bucket from a rope passed through a pulley; and probably used by the besieged to supply themselves with water from a well, without the castle walls. The pulley resembled those now in common use for raising and lowering buckets into wells. This bas-relief had been brought from the north-west palace.

* See Vol. I. page 118. The head of this figure will be placed in the British Museum.

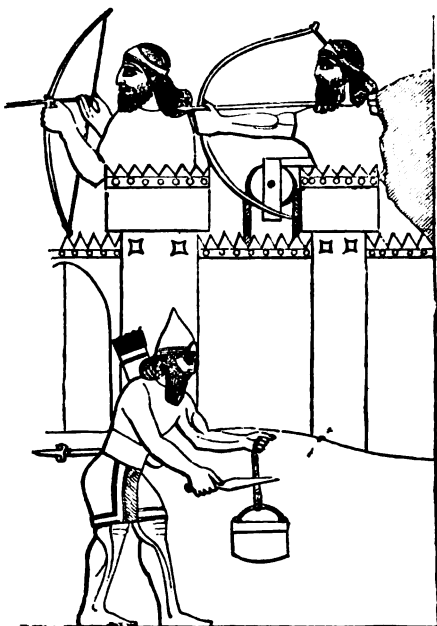

Part of a bas-relief, showing a pulley, and a warrior cutting a bucket from the rope.

There were no slabs against wall *g*, nor near it; those of wall *i* were unsculptured. Upon the two opposite slabs at *ii*, were winged human-headed bulls, resembling in form those at the entrance to the hall; except that the whole, including the head and forepart, was sculptured in low relief. They bore no traces of an inscription. The cap was high and square; and they resembled, in all respects, the remains of the bull discovered in the centre of the mound.

Walls *j*, and *jj*, were cased with unsculptured slabs, each bearing an inscription similar to that on the back of the slabs in the northwest palace: they had evidently been brought from that building.

In wall *k* there were three sculptured slabs. The bas-re-

liefs on Nos. 12 and 16 have already been described.* On No. 17 was a winged figure almost completely destroyed. On the floor, and opposite No. 18 of this wall, was a large square slab bearing a long inscription. It commenced with the name and titles of a king, of whom no other records have yet been discovered. The forms of certain arrow-headed characters show, that this inscription belongs to a period posterior to the reign of the great-grandson of the founder of the northwest palace.

On the backs of several slabs, forming the wall *l*, were bas-reliefs; but all so much injured, that scarcely a trace of the sculpture remained. The slab lying on the pavement opposite this wall was plain; the edges were raised, and it was pierced in the centre.

On all the slabs of wall *m*, was the inscription containing the name of the founder of the northwest palace; and the reversed slab (No. 10), already described, appears to have been a pavement stone, also brought from that building.

To the north of the entrance *c* of the great hall, remains of buildings were discovered, but no entire chamber. A large number of unplaced slabs were scattered about. They appear to have been brought from elsewhere, to be used in the construction of the palace, and to have been abandoned before they reached their destination. Although many detached walls were uncovered, it was impossible to determine the form and size of the chambers to which they belonged.

In front of entrance *c*, and about 220 feet from it, were the remains of a pair of winged bulls, forming another entrance. The whole space between may have been comprised in one large hall, open at the top. The wall forming the east side of this hall, if it had ever been finished, had almost completely disappeared; the traces of it being only marked here and there, by fragments of calcined alabaster. Of the opposite, or western wall, a few sculptured slabs, probably brought from elsewhere,

* See Vol. I. page 64.

were alone standing. To the right and left of the entrance *f*, were the remains of gigantic figures in relief; but they had been exposed to the fire, and had been cracked into a thousand pieces.* They also appear to have belonged to another edifice.

Upon the three slabs forming the wall *r*, were bas-reliefs of considerable interest. They once formed part of another building, but do not belong to either the northwest, or the centre palace. They appear to be of the same period as the bas-reliefs on wall *q*,† already described. In the lower compartment of No. 1 was a charioteer, in a highly ornamented chariot—the horse being held by a groom on foot, preceded by a eunuch. This relief must have formed part of a series; the figures represented in it being probably the attendants of the king. The caparisons of the horses resembled those at Khorsabad. Above this bas-relief was also a chariot, and a man on foot; but they had been almost entirely destroyed. On the lower part of No. 2 was the king placing his foot on the neck of a prostrate prisoner, and raising his spear over him. Following the king is a eunuch carrying a fan; and standing before him, his vizir, also attended by a eunuch. This bas-relief did not form part of the preceding; for the king would have faced the chariot on that slab—a position which he never appears to occupy in the Assyrian sculptures. The upper compartment was nearly defaced; I could, however, trace the figures of warriors discharging their arrows from behind a high shield held in front of them by an attendant.

On the lower part of slab No. 3, was a bas-relief of considerable interest. It represented either a procession of gods, borne on the shoulders of warriors; or warriors returning from the sack of a city, carrying away the idols of the conquered people. Each figure was raised by four men; the first was that of a female, seated on a high-backed arm-chair, look-

* On No. 2, wall *v*, could be still traced a winged figure leading a goat, or an ibex.

† Vol. I. page 68.

ing towards the spectator; the face is, consequently, sculptured in full,—a rare occurrence in Assyrian sculpture. In one hand, she holds a ring; in the other, apparently, a kind of fan or triangle; on the top of her square-horned cap is a star. The next figure is also that of a female, wearing a similar cap, seated in a chair, and holding in her left hand a ring; she carries something in her right hand, but its form cannot be distinguished. The third figure is much smaller in its proportions than those preceding it, and is half concealed in a case, or box, carried on a chair: there is also a ring in its left hand. The fourth is that of a man in the act of walking; in one hand he holds the thunderbolt of the Greek Jove—represented as at Malthaiyah; and in the other, an axe. He wears a richly ornamented tunic descending to the knees. The warriors, bearing these figures, were probably preceded and followed by others, also carrying idols; but no traces of the slabs, forming the rest of the series, could be found amongst the ruins. On each slab between the bas-reliefs, was an inscription, divided into two parts by a perpendicular line.

Trenches were opened, in various directions, across the corner of the mound in which these remains were discovered. Nothing, however, was found but isolated unplaced slabs, and fragments of burnt walls. With adequate means and time at my disposal, I might have determined, by a careful examination, the position of the walls of sun-dried bricks, if they had ever been built. Tracing them, by the fragments remaining, I could have ascertained the form of the chambers, and perhaps that of the entire building. It would have been difficult, however, to distinguish between these walls and the earth and rubbish under which they were buried; and as no more sculptures appeared to exist, I did not think it worth while to incur additional expense in such an examination.

As *the bottom* of the slabs, forming this edifice, was even above the level of *the top* of those in the northwest palace, and as no building had yet been found from which many of the sculptures could have been taken, it appeared to me possible

that the southwest palace stood above other ruins. By way of experiment, I directed long and very deep trenches to be opened in three different directions; nothing, however, was discovered, but a box or square hole, formed by bricks carefully fitted together, containing several small heads in unbaked clay of a dark brown color. These heads are furnished with beards, and have very high pointed caps (not helmets) or mitres.* They were found about twenty feet beneath the surface, and were probably idols placed, for some religious purpose, under the foundations of buildings. Objects somewhat similar, in unbaked clay, were discovered at Khorsabad, buried under the slabs forming the pavement between the gigantic bulls.

Near the entrance *d* of the great hall was found, amidst a mass of charred wood and charcoal, and beneath a fallen slab, part of a beam in good preservation. It appears to be mulberry. This is the only portion of entire wood as yet discovered in the ruins of Assyria.

The southeast corner of the mound, which was considerably higher than any other part, appears to have been the principal burying place of those who occupied the country after the destruction of the oldest of the Assyrian palaces. I have already described two tombs discovered there;† many others were subsequently found. The sarcophagi were mostly of the same shape, that of a dish-cover; but there were other tombs constructed of bricks, well fitted together and covered by a slab, similar to those above the ruins of the edifice in the centre of the mound. In nearly all were earthen vases, copper and silver ornaments, lachrymatories and small alabaster bottles. The skeletons, as soon as uncovered, crumbled to pieces, although entire when first exposed. Two skulls alone have been preserved. Scattered amongst these tombs were a large number of vases of all sizes, lamps, and small objects of pottery—some uninjured, others broken into fragments.

* They will be deposited in the British Museum. † See Vol. I. p. 285, etc.

THE NEW YORK
PUBLIC LIBRARY.

ASTOR LENOX AND
TILDEN FOUNDATIONS.

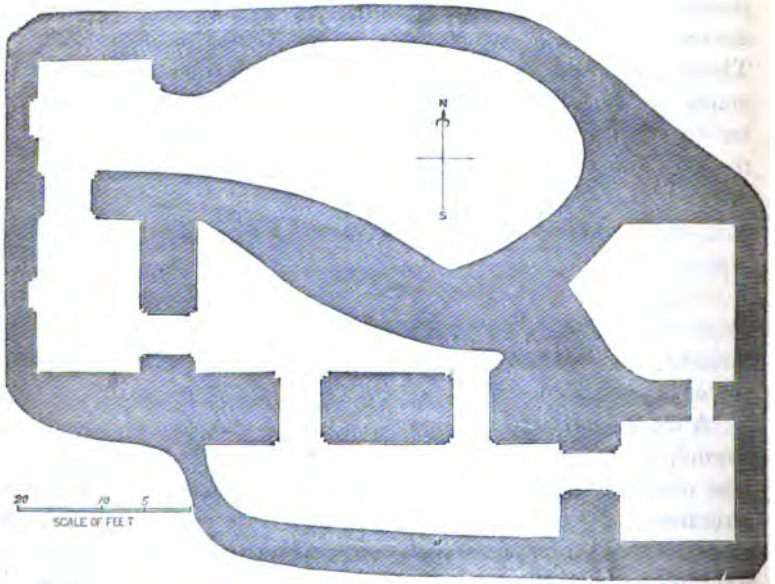

PLAN 5.—EXCAVATIONS IN THE SOUTHEAST CORNER OF THE MOUND. (Nimroud.)

Removing these tombs I discovered beneath them the remains of a building, and explored seven chambers, of which I give the plan. No sculptured slabs or inscriptions were found in them. They resembled those in the ruin to the north of Kouyunjik;* the lower part of the walls being built of plain slabs of limestone, three feet seven inches high and from two to three feet wide, closely fitted together. The upper part, of sun-dried bricks, had been covered by a thick coat of white plaster. I could trace this brick wall about fourteen feet above the slabs. The chambers were paved with limestone. There were no traces of inscriptions, nor were there any remains or fragments by which the comparative age of the building could be determined. In the walls were recesses like those in some of the chambers of the northwest palace, and the door-posts were slightly ornamented with a rough kind of cornice. No remains of color could be seen on the plastered walls.

In the rubbish, near the bottom of these chambers, several small objects were found; amongst them I may mention a female head in white alabaster, highly ornamented and showing traces of color.†

A trench having been opened on the southern edge of the mound, an outer wall, built of squared stones, or rather slabs, was discovered. Behind it were other walls of similar construction leading inwards, and a low platform, resembling a stone seat, in which were cut several holes, like the fireplaces used by the natives of the country to hold charcoal when they roast their meat. The Arabs consequently named the place the "Kibab Shop." The whole was buried under a heap of charcoal and rubbish, in which were found several small vases, and part of a highly polished black slab, having, on either face, a cuneiform inscription, and on the sides figures of animals. Similar remains of building were discovered on the southeastern edge of this part of the mound. The whole, including

* Vol. I. p. 132.

† This head will be placed in the British Museum.

the centre chambers, appeared to form parts of one extensive edifice.

Between the palace in the southwest corner and the ruins last described, was a deep ravine; whether an ancient artificial ascent to the platform, gradually deepened and widened by the winter rains, or entirely a natural water-course, I was unable to determine. Along its sides, to a considerable depth, were exposed masses of brickwork. I directed several trenches to be carried from this ravine into the southeastern corner, in the expectation of finding buildings beneath the chambers already explored. A few fragments of sculptured alabaster, the remains of a winged bull in yellow limestone, and a piece of black stone bearing small figures, evidently from an obelisk resembling that found in the centre palace, were discovered; but to the west of the upper building. I could also trace walls of sun-dried brick, still bearing remains of painted ornaments, but the excavations were not sufficiently extensive to enable me to ascertain the nature and extent of the edifice. Finding no sculptured slabs, I did not continue my researches in this part of the ruins.

It only remains for me to mention a singular discovery on the eastern face of the mound, near its northern extremity. I had opened a trench* from the outer slope, with a view to ascertain the nature of the wall surrounding the inner buildings. I found no traces of stone, or of alabaster slabs; the wall being built of sun-dried bricks and nearly fifty feet thick. In its centre, about fifteen feet below the surface of the platform, the workmen came upon a small vaulted chamber, built of baked bricks. It was about ten feet high, and the same in width. The arch was constructed upon the well-known principle of vaulted roofs—the bricks being placed sideways, one against the other, and having been probably sustained by a framework until the vault was completed. This chamber was nearly blocked up with rubbish, the greater part being a kind of slag.

* *r*, plan 1.

The sides of the bricks, forming the arched roof and the walls, were almost vitrified, and had evidently been exposed to very intense heat. In fact, the chamber had the appearance of a large furnace for making glass, or for fusing metal. I am unable to account for its use. It is buried in the centre of a thick wall, and I could find no access to it from without. If, therefore, either originally a furnace or serving for any other purpose, it must have been used before the upper part of the wall was built.

Several trenches were opened in other parts of the mound.* Every where I found traces of buildings, and generally reached a pavement of baked bricks between ten and fifteen feet beneath the surface. In the northern half of the mound, the name of the founder of the earliest palace was written upon all these bricks. No remains, however, of sculptured slabs or inscriptions were discovered; but many small objects of considerable interest were occasionally taken out of the rubbish: amongst them I may mention three lions' paws in copper, of beautiful form, which may have belonged to the bottom of a couch or throne.†

The ruins were, of course, very inadequately explored; but with the small sum at my disposal I was unable to pursue my researches to the extent that I could have wished. If, after carrying a trench to a reasonable depth and distance, no remains of sculpture or inscription appeared, I abandoned it and renewed the experiment elsewhere. By this mode of proceeding I could ascertain, at least, that in no part of the mound was there any very extensive edifice still standing; although it is highly probable that slabs taken from such an edifice, and placed together in readiness for removal, like those discovered in the centre, may still be buried under the soil. But there is nothing to point out the spot where such remains may be deposited, and I might have sought after them in vain for months.

* At *s*, *p*, *q*, *e*, and *t*, in plan 1.

† Found at *p*, plan 1.

There were too many tangible objects in view to warrant an outlay in experiments, perhaps leading to no results; and I have left a great part of the mound of Nimroud to be explored by those, who may hereafter succeed me in the examination of the ruins of Assyria.

CHAPTER XII.

I HAD long wished to excavate in the mounds of Kalah Sherghat,—ruins rivalling those of Nimroud and Kouyunjik in extent. An Arab, from the Shammar, would occasionally spend a night amongst my workmen, and entertain them with accounts of idols and sculptured figures of giants, which had long been the cause of wonder and awe to the wandering tribes, who occasionally pitch their tents near the place. On my first visit, I had searched in vain for such remains; but the Arabs, who are accustomed to seek for pasture during the spring in the neighborhood, persisted in their assertions, and offered to show me where these strange statues, carved, it was said, in black stone, were to be found. As there is scarcely a ruin in Mesopotamia without its wondrous tale of apparitions and Frank idols, I concluded that Kalah Sherghat was to be ranked amongst the number, and that all these accounts were to be attributed to the fertile imagination of the Arabs. As the vicinity is notoriously dangerous, being a place of rendezvous for all plundering parties, whether of the Shammar, the Aneyza, or the Obeid, I had deferred a visit to the ruins, until I could remain amongst them for a short time under the protection of some powerful tribe. This safeguard was also absolutely necessary in the event of my sending workmen to the place, to carry on excavations.

The pastures in the neighborhood of Mosul having this year been completely dried from the want of rain, the three great divisions of the Jebour Arabs sought the jungles on the

banks of the Tigris below Mosul. Abd'rubbou with his tribe descended the river, and first pitching his tents at Senidij,* near the confluence of the Tigris and the Zab, subsequently moved towards Kalah Sherghat. I thought this a favorable time for excavating in the great mound; and the Sheikh having promised to supply me with Arabs for the work, and with guards for their defence, I sent Mansour, one of my superintendents, to the spot. I followed some days afterwards, accompanied by Mr. Hormuzd Rassam, the Bairakdar, and several well-armed men, chosen from amongst the Jebour who were employed at Nimroud.

We crossed the river on a small raft—our horses having to swim the stream. Striking into the desert by the Wadi Jehennem, we rode through a tract of land, at this time of year usually covered with vegetation; but then, from the drought, a barren waste. During some hours' ride we scarcely saw any human being, except a solitary shepherd in the distance, driving before him his half-famished flocks. We reached at sunset a small encampment of the Jebour. The tents were pitched in the midst of a cluster of high reeds on the banks of the Tigris, and nearly opposite to the tomb of Sultan Abdallah. They were so well concealed, that it required the experienced eye of a Bedouin to detect them,† by the thin smoke rising above the thicket. The cattle and sheep found scanty pasturage in a marsh formed by the river. The Arabs were as poor and miserable as their beasts; they received us, however, with hospitality, and killed a very lean lamb for our entertainment.

Near the encampment was a quadrangle, resembling on a small scale the great inclosures of Nimroud and Kouyunjik,

* A corruption of Sunedik, the plural form of Sanduk, a box. The place is so called by the Arabs from the peculiar form of the rocks near the river.

† In the desert, the vicinity of an encampment is generally marked by some sign well known to the members of the tribe. It would otherwise be very difficult to discover the tents, pitched, as they usually are, in some hollow or ravine to conceal them from hostile plundering parties.

formed by low mounds, and evidently marking the site of an Assyrian town or fort. I searched for some time, but without success, for fragments of pottery or brick bearing the traces of cuneiform characters.

On the following day we passed the bitumen pits, or the "Kiyara," as they are called by the Arabs. They cover a considerable extent of ground; the bitumen bubbling up in springs from crevices in the earth. The Jebour, and other tribes encamping near the pits, carry the bitumen for sale to Mosul, and other parts of the Pashalic. It is extensively used for building purposes, for lining the boats on the river, and particularly for smearing camels, when suffering from certain diseases of the skin to which they are liable. Before leaving the pits, the Arabs, as is their habit, set fire to the bitumen, which sent forth a dense smoke, obscuring the sky, and being visible for many miles. We reached the tents of Abd'rubbou early in the afternoon. They were pitched about ten miles to the north of Kalah Sherghat, at the upper end of a long slip of rich alluvial soil, lying between the river and the range of low hills parallel to it. The great mound was visible from this spot, rising high above the Zor, or jungle, which clothes the banks of the Tigris.

No Sheikh could have made a more creditable show of friendship than did Abd'rubbou. He rode out to meet me, and, without delay, ordered sheep enough to be slain to feast half his tribe. I declined, however, to spend the night with him, as he pressed me to do, on the plea that I was anxious to see the result of the excavations at Kalah Sherghat. He volunteered to accompany me to the ruins after we had breakfasted, and declared that if a blade of grass were to be found near the mound, he would move all his tents there immediately for my protection. In the meanwhile, to do me proper honor, he introduced me to his wives, and to his sister, whose beauty I had often heard extolled by the Jebour, and who was not altogether undeserving of her reputation. She was still unmar-

ried. Abd'rubbou himself was one of the handsomest Arabs in Mesopotamia.

We started for the ruins in the afternoon, and rode along the edge of the jungle. Hares, wolves, foxes, jackals, and wild boars continually crossed our path, and game of all kinds seemed to abound. The Arabs gave chase; but the animals were able to enter the thick brushwood, and conceal themselves before my greyhounds could reach them. Lions are sometimes found near Kalah Sherghat, rarely higher up on the Tigris.* As I floated down to Baghdad a year before, I had heard the roar of a lion not far from this spot: they are, however, seldom seen, and we beat the bushes in vain for such noble game.

As for grass, except in scanty tufts at the foot of the trees in the jungle, there appeared to be none at all. The drought had been felt all over the desert: in the place of the green meadows of last year, covered with flowers, and abounding in natural reservoirs of water, there was a naked yellow waste, in which even the abstemious flocks of the Bedouin could scarcely escape starvation.

As we rode along, Abd'rubbou examined every corner and ravine in the hope of finding an encamping place, and a little pasture for his cattle, but his search was not attended with much success.

The workmen on the mound, seeing horsemen approach, made ready for an encounter, under the impression that we were a foraging party from a hostile tribe. As soon, however, as they recognized us, they threw off the superfluous garments they possessed. Dropping their shirts from their

* The lion is frequently met with on the banks of the Tigris below Baghdad, rarely above. On the Euphrates it has been seen, I believe, almost as high as Bir, where the steamers of the first Euphrates expedition, under Colonel Chesney, were launched. In the Sinjar, and on the banks of the Khabour, they are frequently caught by the Arabs. They abound in Khuzistan, the ancient Susiana: I have frequently seen three or four together, and have hunted them with the chiefs of the tribes inhabiting that province.

shoulders, and tying them round their waist by the arms, they set up the war cry, and rushed in and out of the trenches like madmen.

We heard their shouts from afar, but could see nothing from the dust they made in throwing out the earth. I found that Mansour, the superintendent, had organized a regular system of warlike defence. We were hailed by scouts as we advanced, and there were well-armed watchmen on all the heights. Near each trench were the matchlocks and spears of the workmen, ready for use. "What need of all these precautions?" said I to the timid Christian, as he advanced to receive me. "Yia Rubbi! May God preserve you, O Bey!" replied he. "Our lives, under your shadow, are, of course, of no value—may yours be prolonged. But all the unbelievers in the world—whether they be Aneyza, Shammar, Obeid, or any other manner of infidel—congregate here. If we put a morsel of bread into our mouths—lo! we have to spit it out again, before we can eat it, to meet those accursed Bedouins. If we shut our eyes in sleep, they steal our caldrons and pots, and we have nothing wherewith to bake our bread; so that, if we are not killed, we must be starved. They come from the desert and from the river—from north, south, east and west. But we have eaten your bread, and shall not go unrewarded after all these sufferings." The concluding paragraph accounted to some extent for this exaggerated history of their miseries; but I learnt that scarcely a day had elapsed without the appearance of a body of horsemen from some of the tribes of the desert, and that their visits were not always prompted by the most friendly intentions. The general scarcity, and the rivalry between Sofuk and Nejrîs, had unsettled the Arabs, and every one was on the look-out to help himself to his neighbor's property. Moreover, reports had soon been spread abroad that a Frank, acquainted with all the secrets and hidden mysteries of wisdom, had been successfully searching for treasure. Many of those who rode to Kalah Sherghat, expected to return much wealthier men than they went, by seizing the heaps of gold

and silver to which, as possessors of the country, they were convinced they had better claims than a stranger. However, with the exception of an occasional squabble with the Bedouins who visited the mound, ending in a few broken heads, no very serious engagement had yet taken place—my workmen presenting much too formidable an appearance to be exposed to the attack of any but a large and well-armed party.

The principal excavations had been made on the western side of the mound. After I had succeeded in obtaining silence, and calming the sudden fit of enthusiasm which had sprung up on my arrival, I descended into the trenches. A sitting figure in black basalt, of the size of life, had been uncovered. It was, however, much mutilated. The head and hands had been destroyed and other parts of the statue had been injured. The square stool, or block, upon which the figure sat, was covered on three sides with a cuneiform inscription. The first line, containing the name and titles of the king, was almost defaced; but one or two characters enabled me to restore a name identical with that on the great bulls in the centre of the mound at Nimroud. On casting my eye down the first column of the inscription, I found the names of his father (the builder of the most ancient palace of Nimroud), and of his grandfather, which at once proved that the reading was correct. An Arab soon afterwards brought me a brick bearing a short legend, which contained the three names entire. I was thus enabled to fix the comparative epoch of the newly-discovered ruins. At no time did I feel the value of the genealogical lists on the different monuments at Nimroud, more than when exploring other remains in Assyria. They enabled me to ascertain the comparative date of every edifice and rock tablet with which I became acquainted; and to fix the style of art of each period.

The figure, unlike the sculptures of Nimroud and Khorsabad, was in full, and not in relief; and probably represented the king. Part of the beard was still preserved; the hands appear to have rested on the knees, and a long robe edged

with tassels reached to the ankles. The Arabs declared that this statue had been seen some years before; and it is possible that, at some period of heavy rain, it may have been for a



Sitting figure in basalt, from Kalah Sherghat.

short time exposed to view, and subsequently reburied. It stood on a spur of the mound, and probably in its original position. Mansour had dug trenches at right angles with it on four sides, in the expectation of finding a corresponding figure; but he was disappointed in his search, and no remains of building were discovered near it.

In other parts of the mound there were ruins of walls, but we found no more sculptures. Several tombs, similar to those discovered above the palaces at Nimroud, had been opened; and Mansour brought me earthen vases, and bottles taken from them. He had also picked up, amongst the rubbish, a few fragments of stone bearing cuneiform characters, a piece of copper similarly inscribed, and several bits of black stone with small figures in relief, which appeared to have belonged to an obelisk, like that dug up at Nimroud.

Having made a hasty survey of the trenches, I rode to my tent. It had been pitched in the midst of those of my workmen.

The Arabs had found for their encampment a secure place in the jungle at the northern foot of the mound, and not far from the Tigris. A ditch, leading from the river, nearly surrounded the tents, which were completely concealed by the trees and shrubs. Abd'rubbou remained with me for the night. Whilst I was examining the ruins, he had been riding to and fro, to find a convenient spot for his tents, and grass for his cattle. Such is the custom with the Arabs. When the grass, within a certain distance of their encampment, has been exhausted, they prepare to seek new pastures. The Sheikhs and the principal men of the tribe mount their mares, and ride backwards and forwards over the face of the country, until they find herbage sufficient for the wants of their flocks. Having fixed upon a spot, they return to acquaint their followers with their success, and announce their intention of moving thither on the following morning. The Sheikh's tent is generally the first struck; and the rest of the Arabs, if they feel inclined, follow his movements. If any of the tribe have quarrelled with the chief and wish to desert him, they seize this occasion; leaving their tents standing until the others are gone, and then moving off in another direction.

Abd'rubbou having, at length, fixed upon a suitable spot on the banks of the river, to the south of the mound, he marked out a place for his tents, and sent a horseman to his tribe, with orders for them to move to Kalah Sherghat on the following morning. These preliminaries having been settled, he adjourned to my tent to supper. It was cold and damp, and the Arabs, collecting brushwood and the trunks of trees, made a great fire, which lighted up the recesses of the jungle. As the night advanced, a violent storm broke over us; the wind rose to a hurricane—the rain descended in torrents—the thunder rolled in one long peal—and the vivid streams of lightning, almost incessant, showed the surrounding landscape. When the storm had abated, I walked to a short distance from the tents to gaze upon the scene. The huge fire we had kindled, threw a lurid glare over the trees around our encampment. The

great mound could be distinguished through the gloom, rising like a distant mountain against the dark sky. From all sides came the melancholy wail of the jackals—thousands of these animals having issued from their subterranean dwellings in the ruins, as soon as the last gleam of twilight was fading in the western horizon. The owl, perched on the old masonry, occasionally sent forth its mournful note. The shrill laugh of the Arabs would sometimes rise above the cry of the jackal. Then all earthly noises were buried in the deep roll of the distant thunder. It was desolation such as those alone who have witnessed such scenes, can know—desolation greater than the desolation of the sandy wastes of Africa; for there was the wreck of man, as well as that of nature. Some years before, I had passed a night on the same spot. We were four strangers in the land, without guide or defence. Our horses were picketed about us; and although surrounded by dangers, of which we then thought little, and exposed to a continual rain, we ate the frugal fare our own guns had obtained for us; and slept in our cloaks undisturbed, round the embers of the small fire we had lighted.* I did not think then that I should ever revisit the place.

Soon after sunrise on the following morning, stragglers on horseback from Abd'rubbou's late encampment, began to arrive. They were soon followed by the main body of the tribe. Long lines of camels, sheep, laden donkeys, men, women, and children, such as I have described in my visit to Sofuk, covered the small plain, near the banks of the river. A scene of activity and bustle ensued. Every one appeared desirous to outdo his neighbor in vehemence of shouting, and violence of action. A stranger would have fancied that there was one general quarrel; in which, out of several hundred men and women concerned, no two persons took the same side of the question. Every one seemed to differ from every one else. All this confusion, however, was but the result of a friendly

* Ainsworth's Travels in Asia Minor, Mesopotamia, &c., vol. ii.

debate on the site of the respective tents; and when the matter had been settled to the general satisfaction, without recourse to any more violent measures than mere yelling, each family commenced raising their temporary abode. The camels being made to kneel down, and the donkeys to stop in the place fixed upon, the loads were rolled off their backs. The women next spread the coarse, black, goat-hair canvas. The men rushed about with wooden mallets to drive in the stakes and pegs; and in a few minutes the dwellings, which were to afford them shelter until they needed shelter no longer, and under which they had lived from their birth upwards, were complete. The women and girls were then sent forth to fetch water, or to collect brushwood and dry twigs for fire. The men, leaving all household matters to their wives and daughters, assembled in the tent of the Sheikh; and crouching in a circle round an entire trunk of an old tree, which was soon enveloped in flames, they prepared to pass the rest of the day in that desultory small-talk, relating to stolen sheep, stray donkeys, or successful robberies, which fills up the leisure of an Arab, unless he be better employed in plundering, or in war.

There is a charm in this wandering existence, whether of the Kurd or the Arab, which cannot be described. I have had some experience in it, and look back with pleasure to the days I have spent in the desert, notwithstanding the occasional inconveniences of such a life, not the least of them being a strong tendency on the part of all nomads to profess a kind of communist philosophy, supposed in Europe to be the result of modern wisdom; but which appears to have been known, from the earliest times, in the East. Friends and strangers are not always exempted from the rules of this philosophy, and, as reciprocity is as little understood in the Asiatic, as in the European system, their property is made no less free with than that of Job was, by Arabs and Chaldees, some four thousand years ago. Still this mode of life has not always a bad effect on human nature; on the contrary, it frequently acts favorably. One cannot but admire the poor half-naked Arab, who, intrusted

with a letter or message from his Sheikh to the haughty Pasha of Baghdad, walks proudly up to the great man's sofa, and seats himself, unbidden, upon it as an equal. He fulfils his errand as if he were half ashamed of it. If it be too late to return to his tent that night, or if business still keep him from the desert, he stretches himself under a tree outside the city gate, that he may not be degraded by sleeping under a roof or within walls. He believes that the town corrupts the wanderer; and he remembers that, until the Sheikh of the desert visited the citizens, and was feasted in the palaces of their governors, oppression and vices most odious to the Arab were unknown in his tribe.

Leaving Abd'rubbou and his Arabs to pitch their tents, and settle their domestic matters, I walked to the mound. The trenches dug by the workmen around the sitting figure, were almost sufficiently extensive to prove, that no other remains of building existed in its immediate vicinity. Had not the figure been in an upright position I should have concluded, at once, that it had been brought from elsewhere; as I could not find traces of pavement, nor any fragments of sculpture or hewn stone, near it. Removing the workmen, therefore, from this part of the mound, I divided them into small parties, and employed them in making experiments in different directions. Wherever trenches were opened, remains of the Assyrian period were found, but only in fragments; such as bits of basalt, with small figures in relief, portions of slabs bearing cuneiform inscriptions, and bricks similarly inscribed. Many tombs were also uncovered. Like those of Nimroud, they had been made long after the destruction of the Assyrian building, and in the rubbish and earth which had accumulated above it. The sarcophagi resembled those I have already described—large cases of baked clay, some square, others in the form of a dish-cover; as at Nimroud, they were all much too small to hold a human body, unless it had been violently forced in, or the limbs had been separated. That the body had not been burned, was proved by all the bones of the skeleton being found entire

They may have been exposed, as is the custom amongst the Parsees, until, by the usual process of decomposition, or from the flesh being devoured by birds and beasts of prey, the bones were left naked; they may then have been collected, and buried in these earthen cases. In the sarcophagi were found numerous small vases, metal ornaments, and a copper cup, resembling in shape and in the embossing upon it, that represented in the hand of the king, in one of the bas-reliefs of a chamber of the northwest palace of Nimroud.*

Above these ancient tombs were graves of more recent date; some of them, indeed, belonged to the tribes which had, but a few days before, encamped amongst the ruins.† The tenant of one had been removed from his last resting-place by the hungry hyenas and jackals, who haunt these depositories of the dead. The rude casing of stones, forming the interior of an Arab grave, was exposed to view; and the bones and skull, still clothed with shreds of flesh, were scattered around.

Although I remained two days at Kalah Sherghat, I was not able to find the platform of sun-dried bricks upon which the edifice, now in ruins, and covered with earth, must originally have been built. Remains of walls were found in abundance; but they were evidently of a more recent period than the Assyrian building, to which the inscribed bricks, and the fragments of sculptured stone belonged. The trenches opened by the workmen were deep; but still they did not, I think, reach the platform of the older building. The ruins were consequently not thoroughly explored. I saw no remains of the alabaster or Mosul marble, so generally employed in the palaces

* This cup was taken out entire, but was unfortunately broken by the man who was employed to carry it to Mooul.

† The Arabs generally seek some elevated spot to bury their dead. The artificial mounds, abounding in Mesopotamia and Assyria, are usually chosen for the purpose, and there is scarcely one whose summit is not covered with them. On this account I frequently experienced great difficulty whilst excavating, and was compelled to leave unexamined one or two ruins, into which I wished to open trenches.

to the north of Kalah Sherghat. As quarries of that stone do not exist in that neighborhood, unbaked bricks alone may have been used; and if so, the walls built with them could no longer, without very careful examination, be distinguished from the soil in which they are buried. Had there been sculptured slabs, as at Nimroud, it is probable that fragments, at least, would have been found in the ravines after the earth had been washed away by the rains; and they would then most likely have been taken by the Arabs to decorate their graves (the use to which they are generally applied); but no such fragments were to be met with. All the hewn stones discovered amongst the ruins, except the remains of basalt, were evidently obtained from the hills in the immediate vicinity.*

The Tigris has been gradually encroaching upon the ruins, and is yearly undermining and wearing away the mound. Large masses of earth are continually falling into the stream, leaving exposed to view vases, sarcophagi, and remains of building. Along the banks of the river, to the south of the great mound, several remains of circular masonry, which had the appearance of wells, had been thus uncovered. At the time of my first visit, similar wells were exposed, and we were at a loss to account for their origin and use. I now opened two or three of them. They were filled with earth, mixed with human bones and fragments of vases and pottery;† but whether the bones and vases had been originally deposited there, or had fallen in from above with the rubbish, I could not determine. It is possible that these wells may have been constructed, at a very early period, for purposes of irrigation, or to supply water to the inhabitants of the city; and may have been buried, like the surrounding buildings, long before the erection of the upper edifices, and even before the time of the tombs.

The principal ruin at Kalah Sherghat, as at Nimroud,

* They are of a coarse fossiliferous limestone.

† I found similar wells amongst the ruins on the banks of the rivers of Susiana. One having been opened on the river of Dizful, remains, similar to those described in the text, were found in it.

Khorsabad, and on other ancient Assyrian sites, is a large square mound, surmounted by a cone or pyramid. Long lines of smaller mounds or ramparts, inclose a quadrangle, which, from the irregularities in the surface of the ground, and from the pottery and other rubbish scattered about, appears originally to have been partly occupied by small houses, or unimportant buildings.

At Kalah Sherghat, the high conical mound rises nearly in the centre of the north side of the great platform. Immediately below this cone, and forming a facing to the great mound, is a wall of well-hewn stones or slabs, carefully fitted together, and bevelled at the edges. The battlements still existing on the top of this wall, are cut into gradines, resembling in this respect the battlements of castles and towers, as frequently represented in the Nimroud sculptures. It is probably an Assyrian work, and the four sides of the mound may originally have been similarly cased.

It is not improbable that much of the masonry, still visible on the summit of the mound, may be the remains of an Arab or Turkish fort. The position of Kalah Sherghat is well adapted to a permanent settlement. The lands around are rich, and could be irrigated without much labor. If the population of Mesopotamia were more settled than it now is, the high road between Mosul and Baghdad would be carried along the western banks of the Tigris; and Kalah Sherghat might soon become a place of importance, both as a station and as a post of defence. At present, caravans, carrying on the trade between these two cities, are compelled to make a considerable detour to the left of the river. They pass through the towns of Arbil and Kerkouk, and skirt the Kurdish hills, to avoid the Arab tribes of Tai and Obeid. The journey is long and circuitous; and, from the number of large rivers and torrents to be crossed, merchants are, in the winter and spring, frequently delayed for many days. The road through the desert to the right of the Tigris would be direct and short; water could, of course, be easily obtained during the whole

journey, and there are no streams to interrupt the progress of a caravan. There can be little doubt that, in the days of the Arab supremacy, a flourishing commerce was carried on through this wilderness, and that there was a line of settlements, and stations on both sides of the river; but its banks are now the encamping places of wild tribes; and no merchant dares to brave the dangers of the desert, or to compound, if he escapes them, by the payment of an enormous blackmail to the Arab Sheikhs, through whose pasture-grounds his camels must pass.

The principal mound of Kalah Sherghat, is one of the largest ruins with which I am acquainted in Assyria. I had not the leisure, or the means, to measure it accurately during this visit; but when on the spot with Mr. Ainsworth, we carefully paced round it; and the result, according to that gentleman's calculation, gives a circumference of 4685 yards.* A part of it, however, is not artificial. Irregularities in the face of the country, and natural eminences, have been united into one great platform by layers of sun-dried bricks. It is, nevertheless, a stupendous structure, yielding in magnitude and extent to no other artificial mound in Assyria. In height it is unequal; to the south it slopes off nearly to the level of the plain, whilst to the north, where it is most lofty, its sides are perpendicular, in some places rising nearly one hundred feet above the plain.

I will not attempt to connect, without better materials than we now possess, the ruins of Kalah Sherghat with any ancient city whose name occurs in the sacred books, or has been preserved by ancient geographers. That it was one of the most ancient cities of Assyria, the identification of the name of the king, found on its monuments and bricks, with that of the founder of the centre palace of Nimroud, will be sufficient to prove; but whether it be Chalah, one of the four primitive cities mentioned in Genesis,† or the Ur of Abraham, still

* Journal of the Royal Geographical Society, vol. xi. p. 5. † Chap. x. 11.

existing in the time of Ammianus Marcellinus,* I will not venture to determine. Of the geography of ancient Assyria, we know scarcely any thing. When even the site of Nineveh could not recently be determined with any degree of certainty, we can scarcely expect to be able to identify the ruins of less important places. We possess but few names of cities preceding the Persian conquest; and the accounts handed down to us are too meagre and vague, to lead to the identification of the site of any of them. An extended knowledge of the monuments of Assyria, and an acquaintance with the contents of the inscriptions, may, hereafter, enable us not only to fix the position of these cities, but to ascertain the names of many more, which must have existed in so well-peopled a country, and may have perished on the fall of the Empire.

Having directed Mansour to continue the excavations, I prepared to return to Mosul. Abd'rubbou offered to accompany me, and as the desert between Kalah Sherghat and Hammum Ali was infested by roving parties of the Shammar and Aneyza Arabs, I deemed it prudent to accept his escort. He chose eight horsemen from his tribe, and we started together for the desert.

We slept the first night at the tents of a Seyyid, or descendant of the Prophet, of some repute for sanctity, for the miraculous cure of diseases, which he effected by merely touching the patient. The Arabs are fully persuaded of the existence of this power; but I never saw any one who even pretended to have been cured, although there was certainly no lack of subjects for the Seyyid to practise upon. The old gentleman's daughter, a dark, handsome girl, was claimed by a Sheikh of the Jebour, to whom, according to some accounts, she had been betrothed. The greater part of the night was spent in quarrelling and wrangling on this subject. The Sey-

* Lib. xxv. c. 8. Ammianus does not mention Hatra after, but before Ur; so that Mr. Ainsworth's argument in favor of the identification of the latter city with Kalah Sherghat, is scarcely tenable. (Journal of the Geog. Soc. vol. xi.)

jid resolutely denied the contract, on the mere plea that one of such holy descent could not be united to a man, in whose veins the blood of the Prophet did not flow. Abd'rubbou and his friends, on the other hand, as stoutly contended for the claims of the lover, not treating, I thought, so great a saint with a proper degree of respect. Although my tent was pitched at some distance from the assembly, the discordant voices, all joining at the same time in the most violent discussion, kept me awake until past midnight. Suddenly the disputants appeared to have talked themselves out, and there was a lull. Vainly flattering myself that the company had sunk into sleep, I prepared to follow their example. But I had scarcely closed my eyes, when I was roused by a fresh outbreak of noises. An Arab had suddenly arrived from the banks of the Khabour—the old pasture grounds of the tribe; he was overwhelmed with a thousand questions, and the news he brought of struggles between the Aneyza and the Asai, and the defeat of the former enemies of the Jebour, led to continual bursts of enthusiasm, and to one or two attempts to raise a general shouting of the war-cry. Thus they passed the night, to my great discomfort.

On the morrow I started early with Abd'rubbou and his horsemen. We struck directly across the desert, leaving my servants and baggage to follow leisurely along the banks of the river, by a longer but safer road. When we were within four or five miles of that part of the Tigris at which the raft was waiting for me, I requested Abd'rubbou to return, as there appeared to be no further need of an escort. Mr. Hormuzd Rassam and myself galloped over the plain. We disturbed, as we rode along, a few herds of gazelles, and a solitary wolf, or a jackal; but we saw no human beings. Abd'rubbou and his Arabs were less fortunate; they had scarcely left us when they observed a party of horsemen in the distance, whom they mistook for men of their own tribe returning from Mosul. It was not until they drew nigh that they discovered their mistake. The horsemen were plunderers from the Aneyza. The

numbers were pretty equal. A fight ensued, in which two men on the side of the enemy, and one of the Jebour, were killed; but the Aneyza were defeated, and Abd'rubbou carried off, in triumph, a couple of mares.

A few days after my return to Nimroud, the Jebour were compelled, from want of pasturage, to leave the neighborhood of Kalah Sherghat. The whole desert, as well as the jungle on the banks of the river, which generally supplied, even in the driest seasons, a little grass to the flocks, was dried up. Abd'rubbou, with his tribe, moved to the north. A few of his people came to Nimroud to cultivate millet; but the Sheikh himself, with the greater part of his followers, left the district of Mosul altogether, and migrated to the sources of the Khabour, and to the Nisibin branch of that river—the ancient Mygdonius. The desert to the south of the town was now only frequented by wandering parties of plunderers, and the position of my workmen at Kalah Sherghat became daily more insecure. After they had been once or twice exposed to molestation from the Aneyza, and the Obeid, I found it necessary to withdraw them—had I not, they would probably have run away of themselves. I renounced the further examination of these ruins with regret, as they had not been properly explored; and I have little doubt, from the fragments discovered, that many objects of interest, if not sculptured slabs, exist in the mound.

Although I was unable, at this time, to remove the sitting figure, I have, since my return to England, at the desire of the Trustees of the British Museum, sent orders for its transport to Baghdad. This has been accomplished under the directions of Mr. Ross. It will, I trust, be ere long added to the Assyrian remains now in the national collection. Although it has unfortunately suffered greatly from long exposure, it is of considerable interest, as being the only specimen, hitherto discovered, of an entire Assyrian figure.

CHAPTER XIII.

ASSYRIA PROPER, like Babylonia, owed its ancient fertility as much to the system of artificial irrigation, so extensively and successfully adopted by the inhabitants of the country, as to the rains which fell during the winter and early spring. The Tigris and Euphrates, unlike the Nile, did not overflow their banks, and deposit a rich manure on the face of the land. They rose sufficiently at the time of the melting of the snows in the Armenian hills, to fill the numerous canals led from them into the adjacent country; but their beds were generally so deep, or their banks so high, that when the stream returned to its usual level, water could only be raised by artificial means.

The great canals dug in the most prosperous period of the Assyrian Empire, and used for many centuries by the inhabitants of the country—probably even after the Arab invasion—have long since been choked up, and are now useless. When the waters of the rivers are high, it is still only by the labor of man that they can be led into the fields. I have already described the rude wheels constructed along the banks of the Tigris. Even these are scarce. The government, or rather the local authorities, levy a considerable tax upon machines for irrigation, and the simple buckets of the Arabs become in many cases the source of exaction or oppression. Few are consequently bold enough to make use of them. The land, therefore, near the rivers, as well as that in the interior of the country out of the reach of the canals, is entirely dependent upon the rains for its fertility.

Rain, amply sufficient to insure the most plentiful crops, generally falls during the winter; the grain, in the days of Herodotus, yielding two and even three hundred fold. Indeed, such is the richness of the soil of Assyria, that even a few heavy showers in the course of the year, at the time of sowing the seed, and when the corn is about a foot above the ground, are sufficient to insure a good harvest.* It frequently, however, happens that the season passes without rain. Such was the case this year. During the winter and spring, no water fell. The inhabitants of the villages, who had been induced to return by the improved administration and conciliatory measures of the late Pasha, had put their whole stock of wheat and barley into the ground. They now looked in despair upon the cloudless sky. I watched the young grass as it struggled to break through the parched earth; but it was burnt up almost at its birth. Sometimes a distant cloud hanging over the solitary hill of Arbela; or rising from the desert in the far west, led to hopes, and a few drops of rain gave rise to general rejoicings. The Arabs would then form a dance, and raise songs and shouts, the women joining with the shrill *tahlehl*. But disappointment always ensued. The clouds passed over, and the same pure blue sky was above us. To me, the total absence of verdure in spring was particularly painful. For months my eye had not rested upon a green thing; and that unchanging yellow, barren waste, has a depressing effect upon the spirits. The Jaif, which the year before had been a flower-garden and had teemed with life, was now as naked and bare as a desert in the midst of summer. I had been looking forward to the return of the grass

* The description of Herodotus agrees exactly with the present state of the country, and with the remains of canals still existing near the two rivers, the Tigris and Euphrates. "The Assyrians," he says, "have but little rain; the lands, however, are fertilized, and the fruits of the earth nourished, by means of the river. This does not, like the Egyptian Nile, enrich the country by overflowing its banks, but is dispersed by manual labor, or by hydraulic engines. The Babylonian district is intersected by a number of canals. Of all countries which have come under my observation this is the most fruitful in corn." (lib. i. c. 193.)

to encamp outside the village, and had meditated many excursions to ancient ruins in the desert and the mountains ; but I was doomed to disappointment like the rest.

The Pasha issued orders that Christians, as well as Mussulmans, should join in a general fast and in prayers. Supplications were offered up in the churches and the mosques. The Mohammedans held a kind of three days Ramazan, starving themselves during the day, and feasting during the night. The Christians abstained from meat for the same length of time. If a cloud were seen on the horizon the inhabitants of the villages, headed by their mullahs, would immediately walk into the open country to chant prayers and verses from the Koran. Sheikhs—crazy ascetics who wandered over the country, either half-clothed in the skins of lions or gazelles, or stark naked—burnt themselves with hot irons, and ran shouting about the streets of Mosul. Even a kind of necromancy was not neglected, and the Cadi and the Turkish authorities had recourse to all manner of mysterious incantations, which were pronounced to have been successful in other parts of the Sultan's dominions on similar occasions. A Dervish returning from Mecca, had fortunately brought with him a bottle of the holy water of Zemzem. He offered it, for a consideration, to the Pasha, declaring that when the sacred fluid was poured out in the great mosque, rain must necessarily follow. The experiment had never been known to fail. The Pasha paid the money,—some twenty purses,—and emptied the bottle ; but the results were not such as had been anticipated ; and the dervish, when sought after to explain, was not to be found.

There was no rain, not even the prospect of a shower. A famine appeared to be inevitable. It was known, however, that there were abundant supplies of corn in the granaries of the principal families of Mosul ; and the fact having been brought to the notice of the Pasha, he at once ordered the stores to be opened, and their contents to be offered for sale in the market at moderate prices. As usual, the orders were given to the very persons who were speculating upon the mis-

eries of the poor and needy—to the *cadi*, the *mufti*, and the head people of the town. They proceeded to obey, with great zeal and punctuality, the orders of his Excellency; but somehow or another overlooked their own stores and those of their friends, and ransacked the houses of the rest of the inhabitants. In a few days, consequently, those who had saved up a little grain for their own immediate wants, were added to the number of the starving; and the necessities and misery of the town were increased.

The Bedouins, who are dependent upon the villages for supplies, now also began to feel the effects of the failure of the crops. As is generally the case in such times, they were preparing to make up for their sufferings by plundering the caravans of merchants, and the peaceable inhabitants of the districts within reach of the desert. Although early in the spring, the Shammar and other formidable tribes had not yet encamped in the vicinity of Mosul; still, casual plundering parties had made their appearance among the villages, and it was predicted that as soon as their tents were pitched nearer the town the country without the walls would be not only very unsafe, but almost uninhabitable.

These circumstances induced me to undertake the removal of the larger sculptures as early as possible. The dry season had enabled me to carry on the excavations without interruption. As no rain fell to loosen the earth above the ruins there was no occasion to prop up the sides of the trenches, or to cover the sculptures: considerable expense was thus saved. Had there been the usual violent storms, not only would the soil have continually fallen in and reburied the building, but the bas-reliefs would have been exposed to injury. A marsh would also have been formed round the base of the mound, completely cutting me off from the river, and impassable to any cart carrying the larger sculptures. My first plan, when anticipating the usual wet weather, was to wait, before moving the bas-reliefs, until the rain had completely ceased, and the low ground under the mound had been dried up. I

could not, in that case, commence operations before the month of May, when the Tigris would still be swollen by the melting of the snows in the Armenian hills. The stream would then be sufficiently rapid to carry to Baghdad a heavily laden raft, without the fear of obstruction from shallows and sand-banks. This year, however, there was no marsh round the ruins, nor had any snow fallen in the mountains to promise a considerable rise in the river. I determined, therefore, to send the sculptures to Busrah in the month of March or April, foreseeing that as soon as the Bedouins had moved northwards from Babylonia, and had commenced their plundering expeditions in the vicinity of Mosul, I should be compelled to leave Nimroud.

The Trustees of the British Museum had not contemplated the removal of either a winged bull or lion, and I had at first believed that, with the means at my disposal, it would have been useless to attempt it. They wisely determined that these sculptures should not be sawn into pieces, to be put together again in Europe, as the pair of bulls from Khorsabad. They were to remain, where discovered, until some favorable opportunity of moving them entire might occur; and I was directed to heap earth over them, after the excavations had been brought to an end. Being loath, however, to leave all these fine specimens of Assyrian sculpture behind me, I resolved upon attempting the removal, and embarkation of two of the smallest and best preserved. Those fixed upon were the lion No. 2, from entrance *b*, hall Y, in plan 3, and a bull from entrance *e*, of the same hall. Thirteen pairs of these gigantic sculptures, and several fragments of others, had been discovered; but many of them were too much injured to be worth moving. I had wished to secure the pair of lions forming the great entrance into the principal chamber of the northwest palace;* the finest specimens of Assyrian sculpture discovered in the ruins. But after some deliberation I determined to leave

* Entrance *a*, chamber B, plan 3.

them for the present ; as, from their size, the expense attending their conveyance to the river would have been very considerable.

I formed various plans for lowering the smaller lion and bull, for dragging them to the river, and for placing them upon rafts. Each step had its difficulties, and a variety of original suggestions and ideas were supplied by my workmen, and by the good people of Mosul. At last I resolved upon constructing a cart, sufficiently strong to bear any of the masses to be moved. As no wood but poplar could be procured in the town, a carpenter was sent to the mountains with directions to fell the largest mulberry tree, or any tree of equally compact grain, he could find ; and to bring beams of it, and thick slices from the trunk, to Mosul.

By the month of March this wood was ready. I purchased from the dragoman of the French Consulate a pair of strong iron axles, formerly used by M. Botta in bringing sculptures from Khorsabad. Each wheel was formed of three solid pieces, nearly a foot thick, from the trunk of a mulberry tree, bound together by iron hoops. Across the axles were laid three beams, and above them several cross-beams, all of the same wood. A pole was fixed to one axle, to which were also attached iron rings for ropes, to enable men, as well as buffaloes, to draw the cart. The wheels were provided with movable hooks for the same purpose.

Simple as this cart was, it became an object of wonder in the town. Crowds came to look at it, as it stood in the yard of the vice-consul's khan ; and the Pasha's tepjis, or artillerymen, who, from their acquaintance with the mysteries of gun carriages, were looked up to as authorities on such matters, daily declaimed on the properties and use of this vehicle, and of carts in general, to a large circle of curious and attentive listeners. As long as the cart was in Mosul, it was examined by every stranger who visited the town. But when the news spread that it was about to leave the gates, and to be drawn over the bridge, the business of the place was completely sus-

pended. The secretaries and scribes from the palace left their divans; the guards their posts; the bazars were deserted; and half the population assembled on the banks of the river to witness the manœuvres of the cart. A pair of buffaloes, with the assistance of a crowd of Chaldæans and shouting Arabs, forced the ponderous wheels over the rotten bridge of boats.* The multitude seemed to be fully satisfied with the spectacle. The cart was the topic of general conversation in Mosul until the arrival, from Europe, of some children's toys,—barking dogs and moving puppets—which gave rise to fresh excitement, and filled even the gravest of the clergy with wonder at the learning and wisdom of the Infidels.

To lessen the weight of the lion and bull, without in any way interfering with the sculpture, I reduced the thickness of the slabs, by cutting away as much as possible from the back. Their bulk was thus considerably diminished; and as the back of the slab was never meant to be seen, being placed against the wall of sun-dried bricks, no part of the sculpture was sacrificed. As in order to move these figures at all, I had to choose between this plan and that of sawing them into several pieces, I did not hesitate to adopt it.

To enable me to move the bull from the ruins, and to place it on the cart in the plain below, it was necessary to cut a trench nearly two hundred feet long, about fifteen feet wide, and, in some places, twenty feet deep. A road was thus constructed from the entrance, in which stood the bull, to the edge of the mound. There being no means at my disposal to raise the sculpture out of the trenches, like the smaller bas-reliefs, this road was necessary. It was a tedious undertaking, as a

* The bridge of Mosul consists of a number of rude boats bound together by iron chains. Planks are laid from boat to boat, and the whole is covered with earth. During the time of the floods this frail bridge would be unable to resist the force of the stream; the chains holding it on one side of the river are then loosened, and it swings round. All communication between the two banks of the river is thus cut off, and a ferry is established until the waters subside, and the bridge can be replaced.

very large accumulation of earth had to be removed. About fifty Arabs and Nestorians were employed in the work.

On opening this trench it was found, that a chamber had once existed to the west of hall Y. The sculptured slabs, forming its sides, had been destroyed or carried away. Part of the walls of unbaked bricks, however, could still be traced. The only bas-relief discovered was lying flat on the pavement, where it had evidently been left when the adjoining slabs were removed. It has been sent to England, and represents a lion hunt. Only one lion, wounded, and under the horse's feet, is visible. A warrior, in a chariot, is discharging his arrows at some object before him. It is evident that the subject must have been continued on an adjoining slab, on which was probably represented the king joining in the chase. This small bas-relief is remarkable for its finish, the elegance of the ornaments, and the great spirit of the design. In these respects it resembles the battle-scene in the southwest palace;* and I am inclined to believe that they both belonged to this ruined chamber; in which, perhaps, the sculptures were more elaborate and more highly finished than in any other part of the building. The work of different artists may be plainly traced in the Assyrian edifices. Frequently where the outline is spirited and correct, and the ornaments designed with considerable taste, the execution is defective or coarse; evidently showing, that whilst the subject was drawn by a master, the carving of the stone had been intrusted to an inferior workman. In many sculptures some parts are more highly finished than others, as if they had been retouched by an experienced sculptor. The figures of the enemy are generally rudely drawn and left unfinished, to show probably, that being those of the conquered or captive race, they were unworthy the care of the artist. It is rare to find an entire bas-relief equally well executed in all its parts. The most perfect hitherto discovered in Assyria are, the lion hunt now in the British Museum, the lion hunt just

* See Vol. I. page 54.

THE NEW YORK
LIBRARY

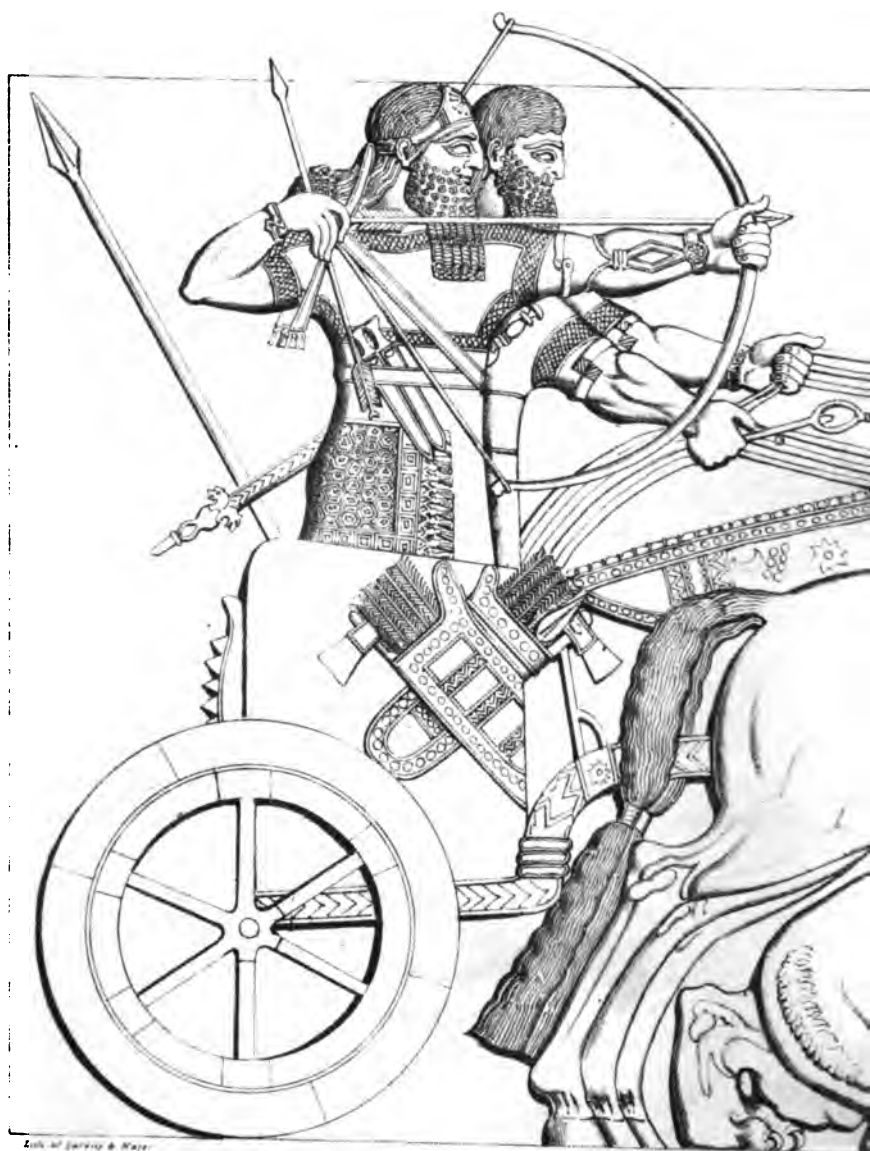

After the painting by Meyer

WARRIOR HUNTING THE

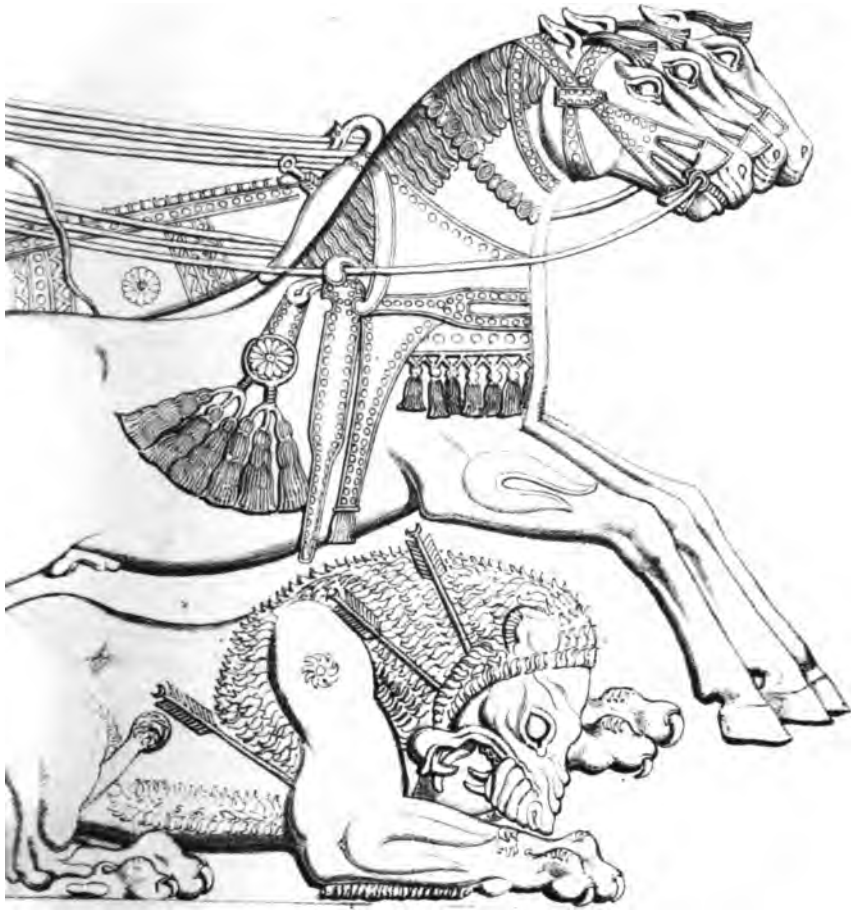

ON (N. W PALACE, NIMROUD.)

1937
MAY 15
1937

described, and the large group of the king sitting on his throne, in the midst of his attendants and winged figures, which formed the end of chamber G, of the northwest palace, and will be brought to England.

Whilst making this trench, I also discovered, about three feet beneath the pavement, a drain, which appeared to communicate with others previously opened in different parts of the building. It was probably the main sewer, through which all the minor water-courses were discharged. It was square, built of baked bricks, and covered in with large slabs and tiles.

As the bull was to be lowered on its back, the unsculptured side of the slab having to be placed on rollers, I removed the walls behind it as far as the entrance *a*. An open space was thus formed, large enough to admit of the sculpture when prostrate, and leaving room for the workmen to pass on all sides of it. The principal difficulty was of course to lower the mass; when once on the ground, or on rollers, it could be dragged forwards by the united force of a number of men; but, during its descent, it could only be sustained by ropes. If not strong enough to bear the weight, they chanced to break, the sculpture would be precipitated to the ground, and would, probably, be broken in the fall. The few ropes I possessed had been expressly sent to me, across the desert, from Aleppo; but they were small. From Baghdad, I had obtained a thick hawser, made of the fibres of the palm. In addition I had been furnished with two pairs of blocks, and a pair of jack-screws belonging to the steamers of the Euphrates expedition. These were all the means at my command for moving the bull and lion. The sculptures were wrapped in mats and felts, to preserve them, as far as possible, from injury in case of a fall; and to prevent the ropes chipping or rubbing the alabaster.

The bull was ready to be moved by the 18th of March. The earth had been taken from under it, and it was now only supported by beams resting against the opposite wall. Amongst the wood obtained from the mountains were several thick rollers. These were placed upon sleepers, or half beams,

formed out of the trunks of poplar trees, well greased and laid on the ground parallel to the sculpture. The bull was to be lowered upon these rollers. A deep trench had been cut behind the second bull, completely across the wall, and, consequently, extending from chamber to chamber. A bundle of ropes coiled round this isolated mass of earth, served to hold two blocks, two others being attached to ropes wound round the bull to be moved. The ropes, by which the sculpture was to be lowered, were passed through these blocks; the ends, or falls of the tackle, as they are technically called, being led from the blocks above the second bull, and held by the Arabs. The cable having been first passed through the trench, and then round the sculpture, the ends were given to two bodies of men. Several of the strongest Chaldæans placed thick beams against the back of the bull, and were directed to withdraw them gradually, supporting the weight of the slab, and checking it in its descent, in case the ropes should give way.

My own people were reinforced by a large number of the Abou Salmañ. I had invited Sheikh Abd-ur-rahman to be present, and he came attended by a body of horsemen. The inhabitants of Naifa and Nimroud having volunteered to assist on the occasion, were distributed amongst my Arabs. The workmen, except the Chaldæans who supported the beams, were divided into four parties, two of which were stationed in front of the bull, and held the ropes passed through the blocks. The rest clung to the ends of the cable, and were directed to slack off gradually as the sculpture descended.

The men being ready, and all my preparations complete, I stationed myself on the top of the high bank of earth over the second bull, and ordered the wedges to be struck out from under the sculpture to be moved. Still, however, it remained firmly in its place. A rope having been passed round it, six or seven men easily tilted it over. The thick, ill-made cable stretched with the strain, and almost buried itself in the earth round which it was coiled. The ropes held well. The mass descended gradually, the Chaldæans propping it up firmly with

the beams. It was a moment of great anxiety. The drums, and shrill pipes of the Kurdish musicians, increased the din and confusion caused by the war-cry of the Arabs, who were half frantic with excitement. They had thrown off nearly all their garments: their long hair floated in the wind; and they indulged in the wildest postures and gesticulations as they clung to the ropes. The women had congregated on the sides of the trenches, and by their incessant screams, and by the ear-piercing *tahlehl*, added to the enthusiasm of the men. The bull once in motion, it was no longer possible to obtain a hearing. The loudest cries I could produce were buried in the heap of discordant sounds. Neither the hippopotamus hide whips of the *Cawasses*, nor the bricks and clods of earth with which I endeavored to draw attention from some of the most noisy of the group, were of any avail. Away went the bull, steady enough as long as supported by the props behind; but as it came nearer to the rollers, the beams could no longer be used. The cable and ropes stretched more and more. Dry from the climate, as they felt the strain, they creaked and threw out dust. Water was thrown over them, but in vain, for they all broke together when the sculpture was within four or five feet of the rollers. The bull was precipitated to the ground. Those who held the ropes, thus suddenly released, followed its example, and were rolling one over the other, in the dust. A sudden silence succeeded to the clamor. I rushed into the trenches, prepared to find the bull in many pieces. It would be difficult to describe my satisfaction, when I saw it lying precisely where I had wished to place it, and uninjured! The Arabs no sooner got on their legs again, than seeing the result of the accident, they darted out of the trenches, and seizing by the hands the women who were looking on, formed a large circle, and yelling their war-cry with redoubled energy, commenced a most mad dance. The musicians exerted themselves to the utmost; but their music was drowned by the cries of the dancers. Even *Abd-ur-rahman* shared in the excitement, and throwing his cloak to one of his attendants, insisted upon

leading off the debkhé. It would have been useless to endeavor to put any check upon these proceedings. I preferred allowing the men to wear themselves out—a result which, considering the amount of exertion and energy displayed both by limbs and throat, was not long in taking place.

I now prepared, with the aid of Behnan, the Bairakdar, and the Tiyari, to move the bull into the long trench which led to the edge of the mound. The rollers were in good order; and as soon as the excitement of the Arabs had sufficiently abated to enable them to resume work, the sculpture was dragged out of its place by ropes.

Sleepers were laid to the end of the trench, and fresh rollers were placed under the bull as it was pulled forwards by cables, to which were fixed the tackles held by logs buried in the earth, on the edge of the mound. The sun was going down as these preparations were completed. I deferred any further labor to the morrow. The Arabs dressed themselves; and placing the musicians at their head, marched towards the village, singing their war-songs, and occasionally raising a wild yell, throwing their lances into the air, and flourishing their swords and shields over their heads.

I rode back with Abd-ur-rahman. Schloss and his horsemen galloped round us, playing the jerrid, and bringing the ends of their lances into a proximity with my head and body, which was far from comfortable; for it was evident enough that had the mares refused to fall almost instantaneously back on their haunches, or had they stumbled, I should have been transfixd on the spot. As the exhibition, however, was meant as a compliment, and enabled the young warriors to exhibit their prowess, and the admirable training of their horses, I declared myself highly delighted, and bestowed equal commendations on all parties.

The Arab Sheikh, his enthusiasm once cooled down, gave way to moral reflections. "Wonderful! wonderful! There is surely no God but God, and Mohammed is his Prophet," exclaimed he, after a long pause. "In the name of the Most

High, tell me, O Bey, what you are going to do with those stones. So many thousands of purses spent upon such things! Can it be, as you say, that your people learn wisdom from them; or is it, as his reverence the Cadi declares, that they are to go to the palace of your Queen, who, with the rest of the unbelievers, worships these idols? As for wisdom, these figures will not teach you to make any better knives, or scissors, or chintzes; and it is in the making of those things that the English show their wisdom. But God is great! God is great! Here are stones which have been buried ever since the time of the holy Noah,—peace be with him! Perhaps they were under ground before the deluge. I have lived on these lands for years. My father, and the father of my father, pitched their tents here before me; but they never heard of these figures. For twelve hundred years have the true believers (and, praise be to God! all true wisdom is with them alone) been settled in this country, and none of them ever heard of a palace under ground. Neither did they who went before them. But lo! here comes a Frank from many days' journey off, and he walks up to the very place, and he takes a stick (illustrating the description at the same time with the point of his spear), and makes a line here, and makes a line there. Here, says he, is the palace; there, says he, is the gate; and he shows us what has been all our lives beneath our feet, without our having known any thing about it. Wonderful! wonderful! Is it by books, is it by magic, is it by your prophets, that you have learnt these things? Speak, O Bey; tell me the secret of wisdom."

The wonder of Abd-ur-rahman was certainly not without cause, and his reflections were natural enough. Whilst riding by his side I had been indulging in a reverie, not unlike his own, which he suddenly interrupted by these exclamations. Such thoughts crowded upon me day by day, as I looked upon every newly discovered sculpture. A stranger laying open monuments buried for more than twenty centuries, and thus proving,—to those who dwelt around them,—that much of the civiliza

tion and knowledge of which we now boast, existed amongst their forefathers when our "ancestors were yet unborn," was, in a manner, an acknowledgment of the debt which the West owes to the East. It is, indeed, no small matter of wonder, that far distant, and comparatively new nations should have preserved the only records of a people once ruling over nearly half the globe; and should now be able to teach the descendants of that people or those who have taken their place, where their cities and monuments once stood. There was more than enough to excite the astonishment of Abd-ur-rahman, and I seized this opportunity to give him a short lecture upon the advantages of civilization and of knowledge. I will not pledge myself, however, that my endeavors were attended with as much success as those of some may be, who boast of their missions to the East. All I could accomplish was, to give the Arab Sheikh an exalted idea of the wisdom and power of the Franks; which was so far useful to me, that through his means the impression was spread about the country, and was not one of the least effective guarantees for the safety of my property and person.

This night was, of course, looked upon as one of rejoicing. Abd-ur-rahman and his brother dined with me; although, had it not been for the honor and distinction conferred by the privilege of using knives and forks, they would rather have exercised their fingers with the crowds gathered round the wooden platters in the courtyard. Sheep were of course killed, and boiled or roasted whole;—they formed the essence of all entertainments and public festivities. They had scarcely been devoured before dancing was commenced. There were fortunately relays of musicians; for no human lungs could have furnished the requisite amount of breath. When some were nearly falling from exhaustion, the ranks were recruited by others. And so the Arabs went on until dawn. It was useless to preach moderation, or to entreat for quiet. Advice and remonstrances were received with deafening shouts of the

war-cry, and outrageous antics as proofs of gratitude for the entertainment, and ability to resist fatigue.

After passing the night in this fashion, these extraordinary beings, still singing and capering, started for the mound. Every thing had been prepared on the previous day for moving the bull, and the men had now only to haul on the ropes. As the sculpture advanced, the rollers left behind were removed to the front, and thus in a short time it reached the end of the trench. There was little difficulty in dragging it down the precipitous side of the mound. When it arrived within three or four feet of the bottom, sufficient earth was removed from beneath it to admit the cart, upon which the bull itself was then lowered by still further digging away the soil. It was soon ready to be dragged to the river. Buffaloes were first harnessed to the yoke; but, although the men pulled with ropes fastened to the rings attached to the wheels, and to other parts of the cart, the animals, feeling the weight behind them, refused to move. We were compelled, therefore, to take them out; and the *Tiyari*, in parties of eight, lifted by turns the pole, whilst the Arabs, assisted by the people of *Naifa* and *Nimroud*, dragged the cart. The procession was thus formed. I rode first, with the *Bairakdar*, to point out the road. Then came the musicians, with their drums and fifes, drumming and fifing with might and main. The cart followed, dragged by about three hundred men, all screeching at the top of their voices, and urged on by the *Cawasses* and superintendents. The procession was closed by the women, who kept up the enthusiasm of the Arabs by their shrill cries. *Abd-ur-rahman's* horsemen performed divers feats round the group, dashing backwards and forwards, and charging with their spears.

We advanced well enough, although the ground was very heavy, until we reached the ruins of the former village of *Nimroud*.* It is the custom, in this part of Turkey, for the

* The village was moved to its present site after the river had gradually receded to the westward. The inhabitants had been then left at a very inconvenient distance from water.

villagers to dig deep pits to store their corn, barley, and straw for the autumn and winter. These pits generally surround the villages. Being only covered by a light framework of boughs and stakes, plastered over with mud, they become, particularly when half empty, a snare and a trap to the horseman; who, unless guided by some one acquainted with the localities, is pretty certain to find the hind legs of his horse on a level with its ears, and himself suddenly sprawling in front. The corn-pits around Nimroud had long since been emptied of their supplies, and had been concealed by the light sand and dust, which, blown over the plain during summer, soon fill up every hole and crevice. Although I had carefully examined the ground before starting, one of these holes had escaped my notice, and into it two wheels of the cart completely sank. The Arabs pulled and yelled in vain. The ropes broke, but the wheels refused to move. We tried every means to release them, but unsuccessfully. After working until dusk, we were obliged to give up the attempt. I left a party of Arabs to guard the cart and its contents, suspecting that some adventurous Bedouins, attracted by the ropes, mats, and felts, with which the sculpture was enveloped, might turn their steps towards the spot during the night. My suspicions did not prove unfounded; for I had scarcely got into bed before the whole village was thrown into commotion by the reports of firearms, and the war-cry of the Jebour. Hastening to the scene of action, I found that a party of Arabs had fallen upon my workmen. They were beaten off, leaving behind them, however, their mark; for a ball, passing through the matting and felt, struck and indented the side of the bull. I was anxious to learn who the authors of this wanton attack were, and had organized a scheme for taking summary vengeance. But they were discovered too late; for, anticipating punishment, they had struck their tents, and had moved off into the desert.

Next morning we succeeded in clearing away the earth, and in placing thick planks beneath the buried wheels. After a few efforts the cart moved forwards amidst the shouts of the

Arabs; who, as was invariably their custom on such occasions, indulged, whilst pulling at the ropes, in the most outrageous antics. The procession was formed as on the previous day, and we dragged the bull triumphantly down to within a few hundred yards of the river. Here the wheels buried themselves in the sand, and it was night before we contrived, with the aid of planks and by increased exertions, to place the sculpture on the platform prepared to receive it, and from which it was to slide down on the raft. The tents of the Arabs, who encamped near the river, were pitched round the bull, until its companion, the lion, should be brought down; and the two embarked together for Baghdad. The night was passed in renewed rejoicings, to celebrate the successful termination of our labors. On the following morning I rode to Mosul, to enjoy a few days' rest after my exertions.

The bull having thus been successfully transported to the banks of the river, preparations were made, on my return to Nimroud, for the removal of the second sculpture. I ordered the trench, already opened for the passage of the bull, to be continued beyond the entrance formed by the lions, or about eighty feet to the north. It was then necessary to move the slabs from behind these sculptures. The slabs in hall Y were plain, having only the usual inscription. The bas-reliefs on those adjoining the lion, in chamber G, had been almost entirely destroyed, apparently by the action of water.

My preparations were completed by the middle of April. I determined to lower the lion at once on the cart, and not to drag it out of the mound over the rollers. This sculpture, during its descent, was supported in the same manner as the bull had been; but to avoid a second accident, I doubled the number of ropes and the coils of the cable. Enough earth was removed to bring the top of the cart to a level with the bottom of the lion. Whilst clearing away the wall of unbaked bricks, I discovered two small tablets, similar to those previously dug out in chamber B.* On both sides they had the usual stand-

* Vol. I. p. 111.

ard inscription, and they had evidently been placed where found, when the palace was built; probably as coins, and similar tablets, are now laid under the foundation-stones of edifices, to commemorate the period and object of their erection.

As the lion was cracked in more than one place, considerable care was required in lowering and moving it. Both, however, were effected without accident. The Arabs assembled as they had done at the removal of the bull. Abd-urrahman and his horsemen rode over to the mound. We had the same shouting, and the same festivities. The lion descended into the place I had prepared for it on the cart, and was easily dragged out of the ruins. It was two days in reaching the river, as the wheels of the cart sank more than once into the loose soil, and were with difficulty extricated.

The lion and bull were at length placed, side by side, on the banks of the Tigris, ready to proceed to Busrah, as soon as I could make the necessary arrangements for embarking them on rafts.

The sculptures, which I had hitherto sent to Busrah, had been floated down the river on rafts, as far only as Baghdad. There they had been placed in boats built by the natives for the navigation of the lower part of the Tigris and Euphrates. These vessels, principally constructed of thin poplar planks, reeds, and bitumen, were much too small and weak to carry either the lion or the bull; and indeed, had they been large enough, it would have been difficult, if not impossible, in the absence of proper machinery, to move such heavy masses into them. I resolved, therefore, to attempt the navigation of the lower, as well as of the upper, part of the river with rafts; and to embark the lion and bull, at once, for Busrah. The raftmen of Mosul, who are accustomed to navigate the Tigris to Baghdad, but never venture further, pronounced the scheme to be impracticable, and refused to attempt it. Even my friends at Baghdad doubted of my success; principally, however, on the ground that the prejudices and customs of the natives were against me—and every one knows how difficul

it is to prevail upon Easterns to undertake any thing, in opposition to their established habits. Such has been their nature for ages. As their fathers have done, so have they done after them, forgetting or omitting many things, but never adding or improving. As rafts meet with no insurmountable difficulties in descending, even from the mountainous districts of Diarbekir, to Baghdad, there was no good reason why they should not extend their journey as far as Busrah. The real obstructions would occur in the upper part of the river, which abounds in rapids, rocks, and shallows; and not in the lower, where there is depth of water, and nothing to impede the passage of large boats. The stream below Baghdad is sluggish, and the tide ascends nearly sixty miles above Busrah: these were the only objections, and they merely affected the time to be employed in the descent, and not its practicability.

It was impossible by the most convincing arguments, even though supported by the exhibition of a heap of coins, to prevail upon the raftmen of Mosul to construct such rafts as I required, or to undertake the voyage. I applied therefore to Mr. Hector, and through him found a man at Baghdad, who declared himself willing to make the great sacrifice generally believed to be involved in the attempt. He was indebted in a considerable sum of money, and being the owner of a large number of skins, now lying useless, he preferred a desperate undertaking to the prospect of a debtor's prison. It was not in any one's power to persuade him that his raft could reach its destination, or that even he could survive the enterprise; and it would have been equally impossible to convince him that my stake in the matter was greater than his own. As it was evident that no harm would come to him, but that, on the contrary, by entering into my service he would pay the greater part of his debts, and escape a prolonged residence in the gloomy subterranean abodes of hopeless debtors, I felt less compunctions of conscience in resorting to the last extremity. Indeed it was consoling to reflect that it was all for the man's own good. At any rate, I had to choose between leaving the

sculptures on the river bank near Mosul, the sport of mischievous Arabs, and seeing them safely transported to Busrah, and ultimately to England. I did not, therefore, long hesitate upon the course to be pursued.

Mullah Ali—for such was the name of my raft-contractor—at length made his appearance. He was followed by a dirty half-naked Arab, his assistant in the construction of rafts; and, like those who carried on his trade some two thousand years before, by a couple of donkeys laden with skins ready for use. Like a genuine native of Baghdad, he had exhausted his ingenuity in the choice of materials for the composition of his garments. There could not have been a more dexterous mixture of colors than that displayed by his antari, cloak, and voluminous turban. He began, of course, by a long speech, protesting, by the Prophet, that he would undertake for no one else in the world what he was going to do for me; that he was my slave and my sacrifice, and that the man who was not, was worse than an infidel. I cut him short in this complimentary discourse. He then, as is usual in such transactions, began to make excuses, to increase his demands, and to throw difficulties in the way. On these points I declined all discussion, directing Ibrahim Agha to give him an insight into my way of doing business, to recommend him to resign himself to his fate, as the contract had been signed, and to hint that he was now in the power of an authority from which there was no appeal.

Mullah Ali made many vain efforts to amend his condition, and to induce, on my part, a fuller appreciation of his merits. He expected that these endeavors might, at least, lead to an additional amount of bakshish. At last he resigned himself to his fate, and slowly worked, with his assistant, at the binding together of beams, and logs of wood, with willow twigs to form a framework for a raft. There were still some difficulties, and obstacles to be surmounted. The man of Baghdad had his own opinions on the building of rafts in general, founded upon immemorial customs, and the traditions of the

country. I had my theories, which could not be supported by equally substantial arguments. Consequently, he, who had all the proof on his side, may not have been wrong in declaring against any method, in favor of which, I could produce no better evidence than my own will. But, like many other injured men, he fell a victim to the "droit du plus fort," and had to sacrifice, at once, prejudice and habit.

I did not doubt that the skins, once blown up, would support the sculptures without difficulty as far as Baghdad. The journey would take eight or ten days, under favorable circumstances. But there they would be required to be opened and refilled, or the rafts would scarcely sustain so heavy a weight all the way to Busrah; the voyage from Baghdad to that port being considerably longer, in point of time, than that from Mosul to Baghdad. However carefully the skins are filled, the air gradually escapes. Rafts, bearing merchandise, are generally detained several times during their descent, to enable the raftmen to examine and refill the skins. If the sculptures rested upon only one framework, the beams being almost on a level with the water, the raftmen would be unable to get beneath them to reach the mouths of the skins, when they required replenishing, without moving the cargo. This would have been both inconvenient, and difficult to accomplish. I was therefore desirous of raising the lion and bull as much as possible above the water, so as to leave room for the men to creep under them.

It may interest the reader to know how these rafts, which have probably formed for ages the only means of traffic on the upper parts of the rivers of Mesopotamia, are constructed. The skins of full-grown sheep and goats are used. They are taken off with as few incisions as possible, and then dried and prepared. The air is forced in by the lungs. The aperture is then tied up with a string. A square framework, formed of poplar beams, branches of trees, and reeds, having been constructed of the size of the intended raft, the inflated skins are tied to it by osier and other twigs, the whole being firmly bound

together. The raft is then moved to the water and launched. Care is taken to place the skins with their mouths upwards, that in case any should burst, or require filling, they can be easily opened by the raftmen. Upon the framework of wood are piled bales of goods, and property belonging to merchants and travellers. When any person of rank, or wealth, descends the river in this fashion, small huts are constructed on the raft by covering a common wooden *takht*, or bedstead of the country, with a hood formed of reeds and lined with felt. In these huts the travellers live and sleep during the journey. The poorer classes bury themselves, to seek shade or warmth, amongst the bales of goods and other merchandise, and sit patiently, almost in one position, until they reach their destination. They carry with them a small earthen *mangal* or chafing-dish, containing a charcoal fire, which serves to light their pipes, and to cook their coffee and food. The only real danger to be apprehended on the river is from the Arabs; who, when the country is in a disturbed state, invariably attack and pillage the rafts.

The raftmen guide their rude vessels by long oars,—straight poles, at the end of which a few split canes are fastened by a piece of twine. They skilfully avoid the rapids; and, seated on the bales of goods, work continually, even in the hottest sun. They will seldom travel after dark before reaching Tekrit, on account of the rocks and shoals, which abound in the upper part of the river; but when they have passed that place, they resign themselves, night and day, to the sluggish stream. During the floods in the spring, or after violent rains, small rafts may float from Mosul to Baghdad in about eighty-four hours; but the large rafts are generally six or seven days in performing the voyage. In summer, and when the river is low, they are frequently nearly a month in reaching their destination. When the rafts have been unloaded, they are broken up, and the beams, wood, and twigs are sold at a considerable profit, forming one of the principal branches of trade between Mosul and Baghdad. The skins are washed, and afterwards

rubbed with a preparation of pounded pomegranate skins, to keep them from cracking and rotting. They are then brought back, either upon the shoulders of the raftmen or upon donkeys, to Mosul or Tekrit, where the men engaged in the navigation of the Tigris usually reside.

On the 20th of April, there being fortunately a slight rise in the river, and the rafts being ready, I determined to attempt the embarkation of the lion and bull. The two sculptures had been so placed on beams that, by withdrawing wedges from under them, they would slide nearly into the centre of the raft. The high bank of the river had been cut away into a rapid slope to the water's edge.

In the morning Mr. Hormuzd Rassam informed me that signs of discontent had shown themselves amongst the workmen, and that there was a general strike for higher wages. They had chosen the time fixed upon for embarking the sculptures, under the impression that I should be compelled, from the difficulty of obtaining any other assistance, to accede to their terms. Several circumstances had contributed to this manœuvre. As I have already mentioned, the want of rain had led to a complete failure of the crops; the country around Nimroud was one yellow barren waste; the villagers had been exposed to several years of tyranny and oppression; during which their small stock of grain, unrenewed by fresh harvests, had gradually diminished. Last autumn, encouraged by the liberal policy of the new Pasha, they had sown the small supply of corn that had been hoarded up, and now that the crops had failed, their last hopes had perished. If they remained in the country, they could only look forward to starvation. They were consequently leaving the plain and migrating to the Kurdish hills, or to the lands under Mardin watered by the Khabour; where, by dint of irrigation, they could hope to raise millet, and other grain, sufficient to meet their wants until the winter rains might promise better times. The country around Nimroud was deserted; not a human being was to be seen within some miles of the place. Abd-ur-rahman, whose crops

had failed like the rest, and who could no longer find pasture for his flocks in the Jaif, had followed the example of the villagers, and was moving northwards. Two or three days before, his Arabs, driving before them their sheep and cattle, and their beasts of burden laden with all the property they possessed, had passed under the mound, on their way to the territories of Beder Khan Bey. The Sheikh himself had spent the night in my house, to take leave of me prior to his departure. I consequently remained alone with my workmen, and the few Arabs who were cultivating millet along the banks of the Tigris. Not only, in case of a further emigration of the Jebour, should I have been left without the means of carrying on the excavations, but I should even have run considerable risk from the parties of Bédouins, who were now taking advantage of the absence of the Abou Salman to cross the river in search of plunder—scouring the country by night and by day. The time chosen by the Jebour to demand higher wages, and to threaten to leave me, was not, therefore, ill-chosen. They were persuaded that I should be compelled to agree to their demands, or to leave the lion and bull where they were. It was not, however, my intention to do either.

I found, on issuing from the house, that the Arabs had already commenced their preparations for departure. The greater part of the tents had been struck, the flocks were collected together, the donkeys were half loaded, and all, men and women, were actively and busily engaged, except half a dozen families who did not show any desire to leave me. A few of the Sheikhs were hanging about the door of my courtyard with gloomy expectant looks, anxious to learn my decision, and little doubting, that on seeing the signs of packing, I would at once yield. However reasonable their demands might have been, the unceremonious fashion in which they were urged was somewhat repugnant to my feelings. There are some bad characters in most societies, who, mischievous themselves, contrive to lead others into mischief; and I was aware that one or two of the chiefs, who did not work, but managed to

raise money from those who did, were the originators of the scheme. I ordered my Cawass and the Bairakdar to seize them at once, and then took leave of those who were preparing to depart. Their plans were somewhat disconcerted, and they went on sullenly with their arrangements. When at length their preparations for the march were completed, they moved off at a very slow pace, looking back continually, not believing it possible that I would obstinately persist in my determination to refuse a compromise. As a last attempt a deputation of one or two Sheikhs came to express a disinterested anxiety for my safety, should the Jebour leave the country. I did my best to quiet their alarms by employing the Tiyari to put my premises into a state of defence, and to reopen all the loop-holes, which Ibrahim Agha had industriously made in the walls surrounding my dwelling, when they had been first built. Defeated in all their endeavors to make me sensible of the danger of my position, they walked sulkily off to join their companions, who took care to encamp for the night within sight of the village.

Many families, however, refusing to desert me, pitched their tents under the walls of my house. The wives, too, of those who were going, had been to me, sobbing and weeping, protesting that the men, although anxious to remain, were afraid to disobey their Sheikhs.

The tents of the Abou Salman were still within reach, and I dispatched a horseman, without delay, to Sheikh Abd-ur-rahman with a note, acquainting him with what had occurred, and requesting him to send me some of his Arabs to assist in embarking the bull. There was a rival tribe of the Jebour encamping at some distance from Nimroud, and I also offered them work.

In the evening, Abd-ur-rahman, followed by a party of horsemen, came to Nimroud. He undertook at once to furnish me with as many men as I might require to place the sculptures on the rafts, and sent orders to his people to delay their projected march.

Next morning, when the Jebour perceived a large body of the Abou Salman advancing towards Nimroud, they repented themselves of their manœuvre, and returned in a body to offer their services on any terms that I might think fit to propose. But I was well able to do without them, and wished to convince them, that the method they had chosen to put forward their demands was neither rational, nor likely to prove successful. I refused, therefore, to listen to any overtures, and commenced my preparations for embarking the lion and bull with the aid of the Chaldæans, the Abou Salman, and such of my Arab workmen as had remained with me.

The beams of poplar wood, forming an inclined plane from beneath the sculptures to the rafts, were first well greased. A raft, supported by six hundred skins, having been brought to the river bank, opposite the bull, the wedges were removed from under the sculpture, which immediately slid down into its place. The only difficulty was to prevent its descending too rapidly, and bursting the skins by the sudden pressure. The Arabs checked it by ropes, and it was placed without any accident. The lion was then embarked in the same way, and with equal success, upon a second raft of the same size as the first; in a few hours the two sculptures were properly secured, and before night they were ready to float down the river to Busrah.

Many slabs, including the large bas-reliefs of the king on his throne, between the eunuchs and winged figures, which formed the end of chamber G, the altar-piece in chamber B, and above thirty cases containing small objects discovered in the ruins, were placed on the rafts with the lion and bull.

After the labors of the day were over, sheep were slaughtered for the entertainment of Abd-ur-rahman's Arabs, and for those who had helped in the embarkation of the sculptures. The Abou Salman returned to their tents after dark. Abd-ur-rahman took leave of me, and we did not meet again: the next day he continued his march towards the district of Jezirah. I heard of him on my journey to Constantinople; the Kurds by

the road complaining, that his tribe were making up the number of their flocks, by appropriating the stray sheep of their neighbors. I had seen much of the Sheikh during my residence at Nimroud; and although, like all Arabs, he was not averse to ask for what he thought there might be a remote chance of getting by a little importunity, he was, on the whole, a very friendly and useful ally.

On the morning of the 22d, all the sculptures having been embarked, I gave two sheep to the raftmen to be slain on the bank of the river, as a sacrifice to insure the success of the undertaking. The carcasses were distributed, as is proper on such occasions, amongst the poor. A third sheep was reserved for a propitiatory offering, to be immolated at the tomb of Sultan Abd-Allah. This saint still appears to interfere considerably with the navigation of the river, and closed the further ascent of the Tigris against the infidel crew of the Frank steamer, because they neglected to make the customary sacrifice. All ceremonies having been duly performed, Mullah Ali kissed my hand, placed himself on one of the rafts, and slowly floated, with the cargo under his charge, down the stream.*

I watched the rafts until they disappeared behind a projecting bank forming a distant reach of the river. I could not

* It is not improbable that the great obelisk which, according to Diodorus Siculus (lib. ii. c. 1), was brought to Babylon from Armenia by Semiramis, was floated down on rafts supported by skins, in the same way that I transported the sculptures of Nineveh to Busrah. It was 130 feet in height, and 25 feet square at the base, and cut out of the solid rock, and must consequently, if the account be not a little exaggerated, have been of prodigious weight. The principal difficulty might probably appear to have been to place it on the raft; but this could have been accomplished by a simple method—by putting the beams forming the framework of wood, and fastening the skins under the obelisk, in some dry place, which would be overflowed during the periodical floods. When the water began to rise, by gradually removing the earth from beneath the skins, they could easily be filled with air; and when the stream had reached the raft they would lift up the obelisk, which could then be floated into the centre of the river. I should have adopted this method of moving the larger lions and bulls, had I been required to send them to Busrah without being provided with any mechanical contrivance, sufficiently powerful to embark such large weights by a simpler process.

forbear musing upon the strange destiny of their burdens ; which, after adorning the palaces of the Assyrian kings, the objects of the wonder, and may be the worship, of thousands, had been buried unknown for centuries beneath a soil trodden by Persians under Cyrus, by Greeks under Alexander, and by Arabs under the first descendants of their prophet. They were now to visit India, to cross the most distant seas of the southern hemisphere, and to be finally placed in a British Museum. Who can venture to foretell how their strange career will end ?

I had scarcely returned to the village, when a party of the refractory Jebour presented themselves. They were now lavish in professions of regret for what had occurred, and in promises for the future, in case they were again employed. They laid the blame of their misconduct upon their Sheikhs, and offered to return at once to their work, for any amount of wages I might think proper to give them. The excavations at Nimroud were almost brought to a close, and I had no longer any need of a large body of workmen. Choosing, therefore, the most active and well-disposed amongst those who had been in my service, I ordered a little summary punishment to be inflicted upon the captive Sheikhs, who had been the cause of the mischief, and then sent them away with the rest of the tribe.

After the departure of the Abou Salman, the plain of Nimroud was a complete desert. The visits of armed parties of Arabs became daily more frequent, and we often watched them from the mound, as they rode towards the hills in search of pillage, or returned from their expeditions driving the plundered flocks and cattle before them. We were still too strong to fear the Bedouins ; but I was compelled to put my house into a complete state of defence, and to keep patrols round my premises during the night to avoid surprise. The Jebour were exposed to constant losses, in the way of donkeys or tent furniture, as the country was infested by petty thieves, who issued from their hiding-places, and wandered to and fro, like jackals,

after dark. Nothing was too small or worthless to escape their notice. I was roused almost nightly by shoutings and the discharge of firearms, when the whole encampment was thrown into commotion at the disappearance of a copper pot or an old grain sack. I was fortunate enough to escape their depredations.

The fears of my Jebour increased with the number of the plundering parties, and at last, when a small Arab settlement, within sight of Nimroud, was attacked by a band of Aneyza horsemen, who murdered several of the inhabitants, and carried away all the sheep and cattle, the workmen protested in a body against any further residence in so dangerous a vicinity. I found that it would not be much longer possible to keep them together, and I determined, therefore, to bring the excavations to an end.

After the departure of the lion and bull, I opened, in the high conical mound or pyramid, a very deep trench, or rather well, which reached nearly to the natural platform of river deposits, forming the basis of the artificial structure. The whole mass was built of sun-dried bricks. There were no remains of stone or alabaster, nor indeed even of baked bricks, except in the thin outer coating of earth and rubbish which had accumulated over the unbaked bricks. As to the use to which this pyramid was applied, I can only conjecture that, being originally cased with stone or colored baked bricks, it may have been raised over the tomb of some monarch; or may have served as an ornament, marking the site of the city from afar; or that it was intended as a watchtower. It was opened on two sides, the trenches being carried completely into the centre; but no entrance, nor any traces of an interior chamber were found. It is possible, however, that on a more complete and extended examination than I was able to attempt, some discovery of great interest might be made, and that this may prove to be the very pyramid, raised above the remains of the founder of the city, by the Assyrian Queen—the “busta Nini” under which may still be some traces of the sepulchre-

of the great king. Although the sides of this high conical mound have been worn away and rounded, it is evident that its original shape was pyramidal. As soon as the outer covering, whether of stone or of baked bricks, had fallen off, or had been removed, the structure of unbaked bricks would rapidly decay, and would naturally assume its present form. That it was not at any period hollow, there can be no doubt. To examine it completely, in order to ascertain whether any remains exist beneath it, would be a labor requiring considerable time and expense.

On the edge of the ravine, to the north of chamber B,* I discovered two enormous winged bulls, about seventeen feet in height, which had fallen from their places. They did not form an entrance, but each one stood alone, adjoining the great slabs with the colossal winged figures in chambers D and E. I was unable to raise them, and the sculptured face of the slab was downwards. They had evidently been long exposed to the atmosphere, and the heads had been greatly injured.

I now commenced burying in those parts of the ruins which still remained exposed, according to the instructions I had received from the Trustees of the British Museum. Had the numerous sculptures been left, without any precaution being taken to preserve them, they would have suffered, not only from the effects of the atmosphere, but from the spears and clubs of the Arabs, who are always ready to knock out the eyes, and to otherwise disfigure, the idols of the unbelievers. The rubbish and earth removed on opening the building, was accordingly brought back in baskets, thrown into the chambers, and heaped over the slabs until the whole was again covered over.

But before leaving Nimroud and reburying its palaces, I would wish to lead the reader once more through the ruins of the principal edifice, and to convey as distinct an idea as I am able of the excavated halls and chambers, as they appeared

* Plan 3.

when fully explored. Let us imagine ourselves issuing from my tent near the village in the plain. On approaching the mound, not a trace of building can be perceived, except a small mud hut covered with reeds, erected for the accommodation of my Chaldæan workmen. We ascend this artificial hill, but still see no ruins, not a stone protruding from the soil. There is only a broad level platform before us, perhaps covered with a luxuriant crop of barley, or may be yellow and parched, without a blade of vegetation, except here and there a scanty tuft of camel-thorn. Low black heaps, surrounded by brushwood and dried grass, a thin column of smoke issuing from the midst of them, may be seen here and there. These are the tents of the Arabs; and a few miserable old women are groping about them, picking up camel's dung or dry twigs. One or two girls, with firm step and erect carriage, are perceived just reaching the top of the mound, with the water-jar on their shoulders, or a bundle of brushwood on their heads. On all sides of us, apparently issuing from under-ground, are long lines of wild-looking beings, with dishevelled hair, their limbs only half concealed by a short loose shirt, some jumping and capering, and all hurrying to and fro, shouting like madmen. Each one carries a basket, and as he reaches the edge of the mound, or some convenient spot near, empties its contents, raising at the same time a cloud of dust. He then returns at the top of his speed, dancing and yelling as before, and flourishing his basket over his head; again he suddenly disappears in the bowels of the earth, from whence he emerged. These are the workmen employed in removing the rubbish from the ruins.

We will descend into the principal trench, by a flight of steps rudely cut into the earth, near the western face of the mound. As we approach it, we find a party of Arabs bending on their knees, and intently gazing at something beneath them. Each holds his long spear, tufted with ostrich feathers, in one hand; and in the other the halter of his mare, which stands patiently behind him. The party consists of a Bedouin Sheikh

from the desert, and his followers ; who, having heard strange reports of the wonders of Nimroud, have made several days' journey to remove their doubts, and satisfy their curiosity. He rises as he hears us approach, and if we wish to escape the embrace of a very dirty stranger, we had better at once hurry into the trenches.

We descend about twenty feet, and suddenly find ourselves between a pair of colossal lions, winged and human-headed, forming a portal. I have already described my feelings when gazing for the first time on these majestic figures. Those of the reader would probably be the same, particularly if caused by the reflection, that before those wonderful forms Ezekiel, Jonah, and others of the prophets stood, and Sennacherib bowed ; that even the patriarch Abraham himself may possibly have looked upon them.

In the subterraneous labyrinth which we have reached, all is bustle and confusion. Arabs are running about in different directions ; some bearing baskets filled with earth, others carrying the water-jars to their companions. The Chaldæans or Tiyari, in their striped dresses and curious conical caps, are digging with picks into the tenacious earth, raising a dense cloud of fine dust at every stroke. The wild strains of Kurdish music may be heard occasionally issuing from some distant part of the ruins, and if they are caught by the parties at work, the Arabs join their voices in chorus, raise the war-cry, and labor with renewed energy. Leaving behind us a small chamber, in which the sculptures are distinguished by a want of finish in the execution, and considerable rudeness in the design of the ornaments, we issue from between the winged lions, and enter the remains of the principal hall. On both sides of us are sculptured gigantic, winged figures ; some with the heads of eagles, others entirely human, and carrying mysterious symbols in their hands. To the left is another portal, also formed by winged lions. One of them has, however, fallen across the entrance, and there is just room to creep beneath it. Beyond this portal is a winged figure, and two slabs with bas-

reliefs; but they have been so much injured that we can scarcely trace the subject upon them. Further on there are no traces of wall, although a deep trench has been opened. The opposite side of the hall has also disappeared, and we only see a high wall of earth. On examining it attentively, we can detect the marks of masonry; and we soon find that it is a solid structure built of bricks of unbaked clay, now of the same color as the surrounding soil, and scarcely to be distinguished from it.

The slabs of alabaster, fallen from their original position, have, however, been raised; and we tread in the midst of a maze of small bas-reliefs, representing chariots, horsemen, battles, and sieges. Perhaps the workmen are about to raise a slab for the first time; and we watch with eager curiosity, what new event of Assyrian history, or what unknown custom or religious ceremony, may be illustrated by the sculpture beneath.

Having walked about one hundred feet amongst these scattered monuments of ancient history and art, we reach another doorway formed by gigantic winged bulls in yellow limestone. One is still entire; but its companion has fallen, and is broken into several pieces—the great human head is at our feet.

We pass on without turning into the part of the building to which this portal leads. Beyond it we see another winged figure, holding a graceful flower in its hand, and apparently presenting it as an offering to the winged bull. Adjoining this sculpture we find eight fine bas-reliefs. There is the king, hunting, and triumphing over, the lion and wild bull; and the siege of the castle, with the battering-ram. We have now reached the end of the hall, and find before us an elaborate and beautiful sculpture, representing two kings, standing beneath the emblem of the supreme deity, and attended by winged figures. Between them is the sacred tree. In front of this bas-relief is the great stone platform, upon which, in days of old, may have been placed the throne of the Assyrian

monarch, when he received his captive enemies, or his courtiers.

To the left of us is a fourth outlet from the hall, formed by another pair of lions. We issue from between them, and find ourselves on the edge of a deep ravine, to the north of which rises, high above us, the lofty pyramid. Figures of captives bearing objects of tribute,—ear-rings, bracelets, and monkeys,—may be seen on walls near this ravine; and two enormous bulls, and two winged figures above fourteen feet high, are lying on its very edge.

As the ravine bounds the ruins on this side, we must return to the yellow bulls. Passing through the entrance formed by them, we enter a large chamber surrounded by eagle-headed figures: at one end of it is a doorway guarded by two priests or divinities, and in the centre another portal with winged bulls. Whichever way we turn, we find ourselves in the midst of a nest of rooms; and without an acquaintance with the intricacies of the place, we should soon lose ourselves in this labyrinth. The accumulated rubbish being generally left in the centre of the chambers, the whole excavation consists of a number of narrow passages, panelled on one side with slabs of alabaster; and shut in on the other by a high wall of earth, half buried, in which may here and there be seen a broken vase, or a brick painted with brilliant colors. We may wander through these galleries for an hour or two, examining the marvellous sculptures, or the numerous inscriptions that surround us. Here we meet long rows of kings, attended by their eunuchs and priests,—there lines of winged figures, carrying fir-cones and religious emblems, and seemingly in adoration before the mystic tree. Other entrances, formed by winged lions and bulls, lead us into new chambers. In every one of them are fresh objects of curiosity and surprise. At length, wearied, we issue from the buried edifice by a trench on the opposite side to that by which we entered, and find ourselves again upon the naked platform. We look around in

vain for any traces of the wonderful remains we have just seen, and are half inclined to believe that we have dreamed a dream, or have been listening to some tale of Eastern romance.

Some, who may hereafter tread on the spot when the grass again grows over the ruins of the Assyrian palaces, may indeed suspect that I have been relating a vision.

CHAPTER XIV.

THE chambers at Nimroud had been filled up with earth, and the sculptures thus preserved from injury. The surrounding country became daily more dangerous from the incursions of the Arabs of the desert, who now began to encamp even on the west bank of the Tigris. It was time, therefore, to leave the village. As a small sum of money still remained at my disposal, I proposed to devote it to an examination of the ruins opposite Mosul; particularly of the great mound of Kouyunjik. Although excavations on a small scale had already been made there, I had not hitherto had time to superintend them myself, and in such researches, the natives of the country cannot be trusted. It is well known that almost since the fall of the Assyrian Empire, a city of some extent, representing the ancient Nineveh, although no longer the seat of government, nor a place of great importance, has stood on the banks of the Tigris in this part of its course. The modern city may not have been built above the ruins of the ancient; but it certainly arose in their immediate vicinity, either to the east of the river, or to the west, as the modern Mosul. The alabaster slabs, which had once lined the walls of the old palaces, and still remained concealed by the earth forming the mound, had been frequently exposed by accident or by design. Those who were settling in the neighborhood, soon found that the ruins offered an inexhaustible mine of building materials. The alabaster was dug out to be either used entire in the construction of houses, or to be burnt for lime. A few years ago a bas-

relief had been discovered in one part of the ruins, during a search after stones for the erection of a bridge across the Tigris. The removal of slabs, and the destruction of sculptures for similar purposes, may have been going on for centuries. There was, therefore, good reason to doubt whether any edifice, even in an imperfect state, still existed in Kouyunjik. I knew that under the village, containing the tomb of the prophet Jonah, there were remains of considerable importance, probably as entire as those discovered at Nimroud. They owe their preservation to the existence, from a very remote period, of the tomb and village above them. Portions of sculpture, and inscriptions, had frequently been found, when the inhabitants of the place had dug the foundations of their dwellings. But the prejudices of the people of Mosul forbade any attempt to explore a spot so venerated for its sanctity.

The edifices at Nimroud, being far distant from any large town, when once buried were not disturbed. It does not appear that after the fall of the Empire any place of importance rose near them, except, perhaps, Selamiyah, which is now but an insignificant village, although it may formerly have been a small market town. It is three miles from the mound, and there are no remains near it to show that, at any time since the Assyrian period, it attained a considerable size. It may, consequently, be inferred that the great mound of Nimroud has never been opened, and its contents carried away for building purposes, since the destruction of the last palace, except, as it has already been mentioned, when a late Pasha of Mosul endeavored to remove one or two slabs to repair the tomb of a Mussulman saint.

By the middle of May, I had finished my work at Nimroud. My house was dismantled. The windows and doors, which had been temporarily fitted up, were taken out; and, with the little furniture that had been collected together, were placed on the backs of donkeys and camels to be carried to the town. The Arabs struck their tents and commenced their march. I remained behind until every one had left, and then

turned my back upon the deserted village. We were the last to quit the plains of Nimroud; and, indeed, nearly the whole country to the south of Mosul, as far as the Zab, became, after our departure, a wilderness.

Half way between Mosul and Nimroud the road crosses a low hill. From its crest, both the town and the ruins are visible. On one side, in the distance, rises the pyramid, in the midst of the broad plain of the Jaif; and on the other may be faintly distinguished the great artificial mound of Kouyunjik, and the surrounding remains. The leaning minaret of the old mosque of Mosul, may also be seen springing above the dark patch which marks the site of the town. The river can be traced for many miles, winding in the midst of the plain, suddenly losing itself amongst low hills, and again emerging into the level country. The whole space over which the eye ranges from this spot, was probably once covered with the buildings and gardens of the Assyrian capital—that great city of three days' journey. At an earlier period, that distant pyramid directed the traveller from afar to Nineveh, when the limits of the city were small. It was then one of those primitive settlements which, for the first time, had been formed by the congregated habitations of men. To me, of course, the long dark line of mounds in the distance, were objects of deep interest. I reined up my horse to look upon them for the last time—for from no other part of the road are they visible—and then galloped on towards Mosul.

In excavating at Kouyunjik, I pursued the plan I had adopted at Nimroud. I resided in the town. The Arabs pitched their tents on the summit of the mound, at the entrances to the trenches. The Tiyari encamped at its foot, on the banks of the Khausser, the small stream which flows through the ruins. Here the men and women found a convenient place for their constant ablutions. They were still obliged, however, to fetch water, when required for other purposes, from the Tigris; that from the Khausser being considered heavy and unwholesome. It is rarely drunk by those who live near the

stream, if other water can be obtained from wells, or even from natural pools of rain water. The nearness of the ruins to Mosul, enabled the inhabitants of the town to gratify their curiosity by a constant inspection of my proceedings; and a great crowd of gaping Mussulmans and Christians was continually gathered round the trenches. I rode to the mound early every morning, and remained there during the day.

The French consul had carried on his excavations for some time at Kouyunjik, without finding any traces of building. He was satisfied with digging pits or wells, a few feet deep, and then renouncing the attempt, if no sculptures or inscriptions were uncovered. By excavating in this desultory manner, if any remains of building were under ground, their discovery would be a mere chance. An acquaintance with the nature and position of the ancient edifices of Assyria, will at once suggest the proper method of examining the mounds which inclose them. The Assyrians, when about to build a palace or public edifice, appear to have first constructed a platform, or solid compact mass of sun-dried bricks, about thirty or forty feet above the level of the plain. Upon it they raised the monument. When the building was destroyed, its ruins, already half buried by the falling in of the upper walls and roof, remained of course on the platform; and were in process of time completely covered up by the dust and sand, carried about by the hot winds of summer. Consequently, in digging for remains, the first step is to reach the platform of sun-dried bricks. When this is discovered, the trenches must be opened to the level of it, and not deeper; they should then be continued in opposite directions, care being always taken to keep along the platform. By this means, if there be any ruins, they must necessarily be discovered, supposing the trenches to be long enough; for the chambers of the Assyrian edifices are generally narrow, and their walls, or the slabs which cased them if fallen, must sooner or later be reached.

At Kouyunjik, the accumulation of rubbish and earth was very considerable, and trenches were dug to the depth of twen-

ty feet, before the platform of unbaked bricks was discovered. Before beginning the excavations, I carefully examined all parts of the mound, to ascertain where remains of buildings might most probably exist; and at length decided upon continuing my researches where I had commenced them last summer, near the southwest corner.

The workmen had been digging for several days without finding any other remains than fragments of calcined alabaster, sufficient, however, to encourage me to persevere in the examination of this part of the ruins. One morning as I was in Mosul, two Arab women came to me, and announced that sculptures had been discovered. They had hurried from the mounds as soon as the first slab had been exposed to view; and blowing up the skins, which they always carry about with them, had swam upon them across the river. They had scarcely received the present claimed in the East by the bearers of good tidings, and the expectation of which had led to the display of so much eagerness, than one of my overseers, who was generally known from his corpulence as Toma Shishman, or fat Toma, made his appearance, breathless from his exertions. He had hurried as fast as his legs could carry him over the bridge, to obtain the reward carried off, in this instance, by the women.

I rode immediately to the ruins; and, on entering the trenches, found that the workmen had reached a wall, and the remains of an entrance. The only slab as yet uncovered had been almost completely destroyed by fire. It stood on the edge of a deep ravine which ran far into the southern side of the mound.

As the excavations at Kouyunjik were carried on in precisely the same manner as those at Nimroud, I need not trouble the reader with any detailed account of my proceedings. The wall first discovered proved to be the side of a chamber. By following it we reached an entrance formed by winged bulls, leading into a second hall. In a month nine chambers had been explored.

The palace had been destroyed by fire. The alabaster slabs were almost reduced to lime, and many of them fell to pieces as soon as uncovered. The places, which others had occupied, could only be traced by a thin white deposit, left by the burnt alabaster upon the wall of sun-dried bricks, and having the appearance of a coating of plaster.

In its architecture, the newly discovered edifice resembled the palaces of Nimroud, and Khorsabad. The chambers were long and narrow. The walls were of unbaked bricks, with a panelling of sculptured slabs. The bas-reliefs were, however, much larger in their dimensions than those generally found at Nimroud, being about ten feet high, and from eight to nine feet wide. The winged, human-headed bulls, forming the entrances, were from fourteen to sixteen feet square. The slabs, unlike those I had hitherto discovered, were not divided in the centre by a band of inscription, but were completely covered with figures. The bas-reliefs were greatly inferior in general design, and in the beauty of the details, to those of the earliest palace of Nimroud; but in many parts they were very carefully and minutely finished: in this respect Kouyunjik yields to no other known monument in Assyria. The winged bulls resembled in their head-dress the animals forming the portals in the southern palace at Nimroud, and like them they had four legs.* In the costumes of the warriors, and in the trappings and caparisons of the horses, the sculptures were similar to those of Khorsabad.

Inscriptions were not numerous. They occurred between the legs of the winged bulls, above the head of the king, on bas-reliefs representing the siege or sacking of a city, and on the backs of many slabs; but they were all so much defaced, that I had great difficulty in copying even a few characters from some of them. Those on the bulls were long, the

* It has already been mentioned that the winged lions of the northwest palace at Nimroud were furnished with five legs, that the spectator, in whatever position he stood, might have a perfect front and side view of the animal.

same inscription being continued on the two sides of an entrance. As four pairs of these gigantic figures were discovered, each pair bearing nearly the same inscription, the whole may be restored out of the fragments copied.*

The name of the king, occurring both on the backs of slabs and on the bricks, resembles that occupying the second place in the genealogical list in the short inscriptions on the bulls and lions of the southern, or most recent, palace of Nimroud. He was the son of the builder of Khorsabad. The comparative epoch of the foundation of this edifice can thus be ascertained, and its positive date will probably be hereafter determined. Long before the discovery of the ruins, I had conjectured, from a hasty examination of a few fragments of sculpture and inscription picked up on the mound, that the building, which once stood there, must be referred to the time of the Khorsabad king, or of his immediate predecessors or successors. There are certain peculiarities in the forms of the figures, in the ornaments, and in some of the characters used in the inscriptions, which distinguish the sculpture, and connect them, at the same time, with those of Khorsabad.

In the earth, above the edifice at Kouyunjik, a few earthen vases and fragments of pottery were discovered; but no sarcophagi, or tombs with human remains, like those of Nimroud and Kalah Sherghat. The foundations of buildings, of roughly hewn stone, were also found above the Assyrian ruins. One or two small glass bottles entire, and many fragments of glass, were taken out of the rubbish; and on the floors of the chambers were several small oblong tablets of dark unbaked clay, having a cuneiform inscription over the sides. Detached slabs of limestone, covered with inscriptions, were also found in the ruins.†

I will now describe the subjects of such of the sculptures,

* It will be included in the collection published by the Trustees of the British Museum.

† The greater part of these small objects are on their way to the British Museum.

17. 11. 1917

THE NEW YORK
PUBLIC LIBRARY
ASTOR LENOX TILDEN FOUNDATION
1900

101

as could still be traced on the walls of the chambers. A continued reference to the accompanying plan will be necessary, to convey to the reader an idea of the nature and extent of the edifices partly uncovered.

The first chamber seen, on entering the trenches from the ravine, was that marked A, on the plan. The two slabs which once formed its entrance had been almost entirely destroyed. Upon the lower part of them could be distinguished the feet and claws of an eagle or vulture, and it is probable that the bas-relief, when entire, represented a human figure with the head and extremities of a bird. The relief must have been, I think, even higher than that of the sculptures of Khorsabad. All the slabs within the chamber had been as much injured as those at the entrance. The upper part of the wall had been completely destroyed; on the lower (about three feet of which remained) could be traced processions of warriors, and captives passing through a thickly wooded, mountainous country; the mountains being represented, as in the bas-reliefs of Nimroud, by a network of lines. On the fragment of a slab,* I could distinguish an altar or tripod, with vessels of various shapes near it. A eunuch, carrying an utensil resembling a censor, stood before the altar.†

The southern extremity of hall B, had been completely destroyed by the water-duct which had formed the ravine. Its width was about forty-five feet, and the length of the western wall from the entrance of chamber A (to the south of which it could not be traced), was nearly one hundred and sixty feet. The first and second slabs ‡ on the west side of the hall appear to have been occupied by one subject, the burning and sacking of a city. The bas-reliefs were divided into several parts by parallel lines. In the upper compartment, which occupied about half the sculpture, were represented houses, some two

* No. 11 in the plan.

† All the sculptures in this chamber were so much defaced that I was unable to make sketches of them.

‡ Nos. 1 and 2 in the plan.

and three stories high; they had been fired by the enemy, and flames were seen issuing from the windows and doors. Beneath were three rows of warriors, some marching in file—each corps or regiment being distinguished by the forms of the helmets, arms, and shields of the men. Others were carrying away the spoil, consisting of furniture, vases, chariots, and horses. On the bottom of the slabs were figured vines, bearing grapes. The captured city stood upon a mountain, and above it was a short inscription, probably containing its name, and a record of the event represented by the bas-relief. The legend was unfortunately almost illegible. The two slabs were greatly injured, and in many places had been entirely destroyed.*

On the adjoining slab was a mountain clothed with forests. Scattered amongst the trees were seen many warriors, some descending in military array, and leading prisoners towards a castle, the wall of which could be distinguished on the edge of the slab; others ascending the steep rocks with the aid of their spears, or resting, seated under the trees. The next slab probably contained a part of the same subject, but it had been completely destroyed.

The wall was here interrupted by an entrance into an inner hall, formed by two winged bulls, nearly $16\frac{1}{2}$ feet square, and sculptured out of one slab. The human heads of these gigantic animals had disappeared. The inscription, which originally covered all parts of the slab not occupied by the relief, was so much defaced, that I was only able to copy a few lines of it. This entrance was narrow, scarcely exceeding six feet, differing in this respect from the entrances at Nimroud. The pavement was formed by one slab, elaborately carved with figures of flowers, resembling the lotus, and with other ornaments. Behind the bulls, was a short inscription, containing the name and titles of the king.

* Engravings from drawings of the bas-reliefs discovered at Kouyunjik will be included in my work on the monuments of Nineveh.

Beyond this entrance the walls of the great hall, to the distance of forty-five feet, had been destroyed. On the lower part of a slab,* could be traced the extremities of a human figure, but the remaining sculptures were completely defaced. Of the slabs forming the rest of the wall, to the end of the chamber, only two were sufficiently well preserved to be drawn, even in part—those numbered 9 and 13 in the plan. On the others I could trace, with difficulty, warriors descending and ascending thickly wooded mountains, as in the bas-relief already described. On No. 9 was the interior of a castle, the wall flanked by towers, and having angular battlements; the whole represented, as at Nimroud, by a kind of ground plan. The king, seated within, on a high chair or throne, was receiving his vizir, who was accompanied by his attendants. Behind the king stood two eunuchs, raising fans or fly-flappers over his head. Without the walls were prisoners, their hands confined by manacles; and within were represented the interiors of several houses and tents. In the tents were seen men apparently engaged in a variety of domestic occupations, and many articles of furniture—tables, couches, and chairs. To the tent-poles were suspended some utensils, perhaps vases thus hung up, as is still the custom in the East, to cool water. Above the head of the king was one line of inscription containing his name and titles. The castle was built on a mountain, and was surrounded by trees. It had probably been captured by the Assyrians, and the bas-relief represented the king celebrating his victory, and receiving his prisoners within the walls.

On slab No. 13 was recorded the conquest of a mountainous country. The enemy occupied the summit of a wooded hill, which they defended against the enemy. Numerous Assyrian warriors were seen scaling the rocks, supporting themselves with their spears and with poles, or drawing themselves up by the branches of trees. Others, returning from the com-

* Marked No. 5 in the plan.

bat, were descending the mountains driving captives before them; or carrying away the heads of those whom they had slain.

A spacious entrance at the upper end of the hall opened into a small chamber, which will be hereafter described. The bulls forming this portal were in better preservation than those discovered at the first entrance. The human heads, with the high and elaborately adorned cap, or head-dress of the later Assyrian period, although greatly injured, could still be distinguished. Of the inscription also a considerable portion remained entire.

Upon the two slabs beyond this entrance,* was a subject of considerable interest. Vessels filled with warriors, and females, were represented leaving a castle, built on the sea-shore, and on the declivity of a mountain. A man stood at the castle gate, which opened immediately upon the water. A woman, who had already embarked in one of the ships, was seen stretching out her arms to receive a child which the man was giving to her. The sea was indicated by wavy lines carried across the slab from top to bottom, and by fish, crabs and turtles. The vessels were of two kinds; some had masts and sails as well as oars, others were impelled by rowers alone. They were furnished with two decks. On the upper stood warriors armed with spears, and women wearing high turbans or mitres. On the lower (which was probably divided into two compartments) were double sets of rowers; eight, and sometimes ten men sitting on a side, making sixteen or twenty in all. The sides of the upper deck, as well as the battlements of the castle on the sea-shore, were hung with shields. From the costume of the figures, and the position of the city, it would appear that they were not Assyrians, but a conquered people, flying from the enemy. It will be shown that an Assyrian conquest of the Tyrians, or of some other nation occupying the coasts of the Mediterranean, was probably recorded by the bas-relief.

* Nos. 14 and 15 in the plan.

On the two slabs adjoining the sea-piece* was represented the besieging army. The upper part of both slabs had been destroyed; on the lower were still preserved a few Assyrian warriors, protected by the high wicker shield, and discharging arrows in the direction of the castle. Rows of prisoners, with their hands bound, were also seen led away by the conquerors.

A third entrance, narrower than that on the opposite side of the hall, led into a chamber to the east. It was formed by two winged human-headed bulls and two slabs, with bas-reliefs representing a battle in a hilly country, wooded with pines or fir trees. All these sculptures had been greatly injured.

Beyond this entrance the slabs, to the distance of fourteen feet, had been completely destroyed. The first, partly preserved, was that numbered 20 in the plan. It was divided into six compartments. In the upper was represented the sack of a city, out of which men were dragging chariots, and driving horses and cattle; a second castle stood on a hill above. In the second and third compartments were combats between horsemen, and warriors on foot; and in the remainder, rows of chariots, drawn by two horses, and carrying each three warriors, preceded by horsemen armed with long spears. At the bottom of the slab, and between the warriors, were trees.

Two other slabs were uncovered, but the subjects upon them could not be ascertained. As the trench now approached the ravine, and there appeared to be no chance of finding any sculptures, even sufficiently well preserved to be drawn, I removed the workmen to another part of the ruins.

The doorway on the west side of the hall led into a second hall,† the four sides of which were almost entire. The bas-reliefs had unfortunately suffered greatly from the fire, and in many places the slabs had disappeared altogether. Mixed with

* Nos. 16 and 17 in the plan.

† Hall C in the plan.

the rubbish, which covered this part of the ruins, were fragments of alabaster, and remains of sculpture.

The three first slabs to the left* appear to have been each divided into three compartments. In the first and second, were rows of archers and slingers; and in the third, warriors marching in single file, and each carrying a spear and a shield. On the two following slabs was one subject—the taking by assault of a city or castle, built near a river in a mountainous country, and surrounded by trees. Warriors, armed with spears, were scaling the rocks, and archers, discharging their arrows at the besieged, stood at the foot of the mountain. The upper half of both slabs, containing the greater part of the castle and the figures of those who manned its walls, had been destroyed. On the sixth slab the same castle was continued. The walls were carried down the sides of the mountain to its foot; and houses were represented on the banks of the river. The archers, and spearmen of the besieging army, were assembled without the city. Some warriors had already mounted the walls, and were slaying the besieged on the house-tops; whilst others were leading off the captives they had taken. The river was full of fish, tortoises, and eels.

The adjoining corner stone† was divided into three compartments; the upper contained mountains and trees: in the centre were represented a eunuch, and a bearded scribe writing down, on rolls of parchment or leather, the number of heads of the enemy brought to them by two warriors, who were placing their trophies in a heap at the feet of the registrars. In the lower compartment were three warriors with spears and shields.

On No. 8 was the king in his chariot, preceded by warriors on foot. At the bottom of the slab was a river, and at the top, mountains and trees. This bas-relief was also much injured. On the five following slabs, which were almost en-

* Nos. 1, 2, and 3 in the plan.

† No. 7 in the plan.

tirely defaced, could be traced one subject, the siege and sack of a city. The king appeared in his chariot, and warriors were seen driving off prisoners and cattle. The mountains and river still indicated the scene of the events recorded. On slab No. 14, men and women led off as prisoners, and flocks of sheep and goats, and herds of cattle, were better preserved than the figures on the preceding slabs.

From No. 14 to the entrance *b*, which opened into another hall, the bas-reliefs had been almost completely destroyed. Here and there I could trace warriors discharging their arrows, prisoners and cattle driven away, and a king or warrior in his chariot. There were also the outlines of castles, mountains and trees; but the whole series was far too much injured to be even sketched.

The winged bulls, forming the entrance into the hall to the west, were also in a very dilapidated condition, and the heads were wanting. Between them I discovered a lion-headed human figure, raising a sword or staff in one hand. It was sculptured on a small slab. Half the figure had been destroyed.

Beyond this entrance the walls were in no better condition. On slab No. 27 could be traced a double row of warriors, carrying spears and shields, separated by a river from horsemen riding amongst mountains. No. 28 had been entirely destroyed by a well, opened in this part of the mound, and carried through the wall. On No. 29 could be distinguished men leading horses, and warriors bringing the heads of the slain to the scribes. The bottom of the slab was occupied by horsemen ascending mountains, separated by a river from the figures above. No. 30 was better preserved than any of the preceding slabs. The king stood in a chariot, holding a bow in his left hand, and raising his right in token of triumph. He was accompanied by a charioteer, and by an attendant bearing an umbrella, to which was hung a long curtain falling behind the back of the king, and screening him entirely from the sun. The chariot was drawn by two horses, and was preceded by spearmen and

archers. Above the king was originally a short inscription, probably containing his name and titles, but it had been entirely defaced. Horsemen, crossing well-wooded mountains, were separated from the group just described, by a river abounding in fish.

The remaining bas-reliefs in this chamber appear to have recorded similar events,—the conquests of the Assyrians, and the triumphs of their king. Only four of them unfortunately were sufficiently well preserved to enable me to make drawings; the rest were almost completely destroyed. On Nos. 36 and 37 the taking by assault of a city was portrayed with great spirit. Warriors, armed with spears, were mounting ladders placed against the walls; those who manned them being held in check and assailed by archers who discharged their arrows from below. The enemy defended themselves with spears and bows, and carried small oblong shields. Above the castle, a small inscription recorded most probably the name of the city captured by the Assyrians; it had unfortunately suffered great injury, a few characters only being preserved. Under the castle walls were lines of captives, driven off by the conquerors; and at the bottom and top of the slab were mountains, trees, and a river, to indicate the nature of the country in which the event represented took place.

The entrance *b* of chamber C, formed by two winged bulls, led into a further chamber, a part only of which I was able to explore. The alabaster slabs had in many places completely disappeared, and I could not even trace the walls and form of the apartment. On slabs Nos. 1 and 2 was portrayed a mountainous country; a river ran through the midst of it. The higher parts of the mountains were clothed with a forest of pines or firs, the middle region by vineyards, and the lower by trees, resembling those sculptured on other slabs, probably the dwarf oak of the country. The king was seen riding through the forest in his chariot, accompanied by many horsemen.

The remaining slabs were covered from top to bottom with rows of warriors, spearmen, and archers, in their respective

costumes, and in military array. Each slab must have contained several hundred minute figures, sculptured with great care and delicacy.

I found only one outlet from this chamber, that at entrance *b*. The chambers to the west were discovered by digging through the wall at the upper end of chamber A. Here, too, the fire had raged, and whilst the walls had in many places completely disappeared, the few slabs that still remained in their places were broken into a thousand pieces, and could scarcely be held together whilst I sketched the bas-reliefs. The chambers were half filled by a heap of charcoal, earth, and fragments of burnt alabaster.

Upon the walls of chamber D, were the siege and capture of a city, standing on the banks of a river in the midst of forests and mountains. On one slab could be seen warriors cutting down trees, to form an approach to the castle, whilst others were combating with the enemy in the woods. On the adjoining slabs were warriors scaling the walls, slaughtering sheep, driving off captives and cattle, and carrying away the heads of the slain. Small figures, wearing high caps, and having their hands joined in front, were represented as sitting astride on poles, and borne on men's shoulders. They may have been the divinities, or idols, of the conquered people. The king in his chariot, the umbrella held over his head by a eunuch, was receiving the spoil.

On the bottom of slab No. 7 was a fisherman fishing with a hook and line in a pond. Upon his back was a wicker basket, containing the fish he had caught. This was almost the only fragment of sculpture that I was able to move and send to England, as a specimen of the bas-reliefs of Kouyunjik.

Of the walls of chamber E, the lower part, to the height of about four feet, alone remained. Upon it could be traced long lines of captives, amongst them women carrying their children, and riding on mules. The prisoners were brought by archers before warriors standing, to receive them, with their spears raised, and their shields resting on the ground.

The bas-reliefs on the walls of chamber F, recorded the victories and triumphs of the king in a mountainous country, and the siege of a city standing on the banks of a river. The king stood in his chariot, and around him were warriors leading away horses and captives, bringing heads to the scribes, and contending in battle with the enemy. All the slabs, however, were equally injured. The figures upon them could scarcely be distinguished.

The wide portal, formed by the winged bulls at the upper end of chamber B, opened into a small chamber, which had no other entrance. One side of it was completely destroyed. On the remaining slabs were represented the siege, and sack of a city, standing between two rivers, in the midst of groves of palm trees. From the absence of mountains, the nature of the trees, and the two rivers, it may be conjectured that the sculptures in this chamber recorded the conquest of some part of Mesopotamia, or the subjugation of a people, inhabiting that country, who had rebelled against the authority of the Assyrian king. Fortunately, a short inscription above the captured city has been preserved almost entire; and we may hope to find in it the name of the conquered nation. The king was represented, several times, in his chariot amidst groves of palm trees, and preceded and followed by warriors. The besiegers were seen cutting down the palms, to open and clear the approaches to the city.

A part only of chamber H was uncovered. Several of the slabs appear to have been purposely destroyed, as there were marks of the chisel upon them. One of the winged bulls, forming an entrance at the southern end of the chamber, had fallen from its place. On the slab adjoining it was a gigantic winged human figure, the upper part of which had been defaced. On slabs Nos. 4, 5, 6, and 7, could be traced warriors urging their horses at full speed; some discharging, at the same time, their arrows. Beneath the horsemen were rows of chariots and led horses. After my departure from Mosul, Mr. Ross continued the excavations along this wall for



THE KING IN HIS CHARIOT RETURNING FROM BATTLE. (Kouyupjik.)

THE NEW YORK
PUBLIC LIBRARY.
ASTOR LENOX AND
TILDEN FOUNDATIONS.

a short time, and discovered several other slabs and the openings into three new chambers, one entrance having, it appears, been formed by four lion sphinxes, fragments of which were found amongst the rubbish. The subjects of the bas-reliefs appear to have been nearly the same as those preceding them. Mr. Ross could trace chariots, horsemen, archers, and warriors in mail. The country, in which the events recorded took place, was indicated by a river and palm trees. On one slab were the remains of two lions. This wall having ceased altogether, he first opened a trench in the same direction, but without coming upon other remains of building. Resuming the excavations at right angles to the end of the wall, he discovered, about eighteen feet from it, an immense square slab, which he conjectures to be a dais or altar, resembling that found in the great hall of the principal edifice at Nimroud.* The wall was continued beyond it. The lower part of a few slabs still remained, and it was evident that they had been sculptured; but this part of the building had been so completely destroyed by fire, that Mr. Ross soon renounced any further attempt to examine it.

This was the extent of my discoveries at Kouyunjik. The ruins were evidently those of a palace of great extent and magnificence. From the size of the slabs and the number of the figures, the walls, when entire and painted, as they no doubt originally were, must have been of considerable beauty, and the dimensions of the chambers must have added greatly to the general effect. At that time the palace rose above the river, which swept round the foot of the mound. Then also the edifice, now covered by the village of Nebbi Yunus, stood entire above the stream, and the whole quadrangle was surrounded by lofty walls cased with stone, their towers adorned with sculptured alabaster, and their gateways formed by colossal bulls. The position of the ruins proves, that at one time this was one of the most important parts of Nineveh; and

* See Vol. I. p. 123.

the magnificence of the remains shows, that the edifices must have been founded by one of the greatest of the Assyrian monarchs.

Mr. Ross having been requested, by the Trustees of the British Museum, to carry on the excavations, on a small scale, in Kouyunjik, he judiciously made experiments in various parts of the mound. His discoveries are of great interest, and tend to prove that there were more buildings than one on the platform; but whether they were all of the same epoch I have no means of judging; Mr. Ross not having yet sent me the copies of any inscriptions from the palace last explored by him. Unfortunately the building newly found owes its destruction to fire, like that in the southwest corner. Hitherto Mr. Ross has been unable to move any entire bas-reliefs, although there are fragments which, it is hoped, will be secured, and added to the collection of Assyrian antiquities to be brought to this country.

Mr. Ross, on abandoning the edifice that I had discovered, removed the workmen to the opposite side of the mound. Here he has found a chamber formed by slabs divided in the centre, as at Khorsabad and Nimroud, by bands of inscription, and having bas-reliefs in the two compartments. "The sculptures represent," writes Mr. Ross, "the return of an army in triumph, with chariots, led horses, and captives; marching along the banks of a river, upon which are groves of date trees in fruit. The river is full of fish, tortoises, and crabs. Beyond is a city (also on the banks of the river), out of the gates of which are proceeding men and women on foot, in carts drawn by oxen, and on mules, some bearing presents to the conquerors. Near the castle is a field of millet in ear. In the procession are carried two circular models of towns" (probably representing places captured by the king). "The accumulation of earth above the ruins is so great that the workmen are now tunnelling to reach the sculptures."

At the foot of the mound Mr. Ross has found a monument of considerable interest. It was first uncovered by a man

ploughing. In shape it somewhat resembles a tombstone, being about three feet high and rounded at the top. Upon it is a figure, probably that of a king, and a long inscription in the cuneiform character. Above the figure are various emblems, amongst which is the winged divinity in the circle. It was erect, and supported by brickwork when discovered; and near it was a sarcophagus in baked clay. Mr. Ross suggests that the whole may have been an Assyrian tomb; but I question whether there is sufficient evidence to prove that its original site was where it was found; or that it had not been used, as portions of slabs with inscriptions at Nimroud, by people who occupied the country after the destruction of the pure Assyrian monuments. This interesting relic is nearly perfect, one corner alone having been injured.

In a mound so vast as that of Kouyunjik, it is probable that many remains of the highest interest still exist. As it has been seen, the accumulation of rubbish is so great, that a mere superficial examination would not suffice to prove the absence of subterranean buildings. Hitherto only two corners of the mound have been partially explored; and in both have ruins, with sculptures and inscriptions, been discovered. They have been exposed to the same great conflagration which apparently destroyed all the edifices built upon the platform. It is possible, however, that other parts of these palaces may be found, which, if they have not escaped altogether the general destruction, may at least be sufficiently well preserved to admit of the removal of many important relics. Such was the case at Khorsabad in ruins of much less extent.

Although there may possibly be remains of more than one epoch in Kouyunjik, I much doubt whether there are any edifices earlier than that built by the monarch, who is mentioned in the inscriptions of the most recent palace of Nimroud, as the son of the founder of Khorsabad. His name occurs on all the bricks and monuments hitherto discovered (as far as I am aware) in Kouyunjik, in the neighboring mound of Nebbi Yunus, and in the smaller mounds forming the large quad-

rangle opposite Mosul. From the description given by Mr. Ross of the sculptures he has recently found, I recognize in them, as well as in the bas-reliefs of the palace above described, the style and mode of treatment of Khorsabad and of the latter monuments of Nimroud.*

* In the winter of this year Mr. Ross visited the rock tablets of Bavian, which want of time had, to my great regret, prevented me examining. The account he has obligingly sent me of the result of his journey to these very remarkable remains is so interesting, that I venture to transcribe it. "I left Mosul," he writes, "a little before Asr," (the time of afternoon prayer,) "and reached Baazani after dark. During the night it rained heavily, and I started with rain and a high cutting cold wind, which lasted the whole day. After a very disagreeable ride over the Jebel Makloub and the Missouri hills, I reached Bavian an hour after sunset. The village stands on the Gomel, at the point where the high range of mountains, running behind Sheikh Adi, sinks into hills. It consists of three wretched houses, whose inhabitants" (Kurds) "are in an equally destitute condition. I had great difficulty in procuring any food for my horses and mules; and could find nothing but a little rice to give them—there being neither wheat nor barley in the place. Immediately opposite the village, on the west side of the Gomel, rise the cliffs, on which are the bas-reliefs. There are eight small tablets, each containing the portrait of a king, about four feet high; and one very large tablet with two kings, apparently worshipping two priest-like figures standing, the one on a lion, and the other on a griffin. Above this tablet rose a statue on two lions, but now only the paws of a lion are well preserved; the outline of the head of one can be traced, but the statue is reduced to a square oblong block. I fancy it may have been a sphinx like those of Nimroud. In the river are two masses of rock, with figures of priests or gods standing on the backs of animals, which must have originally been very beautiful. Other large masses of rock are in the water, and may once have borne bas-reliefs. There is also a tablet on which the body of a bull may be traced, but very much defaced. I could not find the figure of the gigantic horseman. It may be that it is so much injured that neither I nor the villagers could discover it. Some of the small tablets are on the perpendicular face of the rock, others are reached by a narrow ledge. Where any footing could be obtained, I trod with my Tiyari woollen shoes. Of all the tablets which I examined, either closely or from below, only one has an inscription. It is a tablet easily approached. The writing runs completely across it, even over the figure of the king; but it is greatly injured from holes having been bored in it, as well as from long exposure—so much so, that I was unable to copy it. On the body of the king, and in the centre of the writing, is an inscription inclosed within a triangle—I suppose a name. The large tablet, and that containing the bull, have chambers cut behind them. I am inclined to think that these chambers were excavated at the same time that the portraits were sculptured. Their use is obvious. They were tombs, and my idea is that the bas-reliefs outside are the portraits of the monarchs who were buried within. Picture to yourself a small room, square in

Further researches at Kouyunjik could scarcely fail to be productive of many interesting and important results. The inscriptions hitherto found amongst the ruins are few in number. The bas-reliefs evidently relate to great events,—to the conquest of distant kingdoms, and the subjugation of powerful nations. The identity of the name of the king who caused them to be executed, with that found on the well-known tablets near Beyrout, at the mouth of the Dog river, or the Nahr-el-Kelb, proves that the Assyrian Empire, at the time of the building of the Kouyunjik palaces, extended to the borders of the Mediterranean; and this, as well as several other circumstances, goes far to show, that the bas-reliefs in which the sea is represented, celebrate the conquest of Tyre or Sidon. But

shape, and with a flat vault. On either side, recesses or niches" (resembling a small oven) "are cut into the wall, evidently to hold a body. These niches, being only about four feet long, may be thought too small to receive a man; but I imagine that the corpse was crammed into a sarcophagus, similar to those discovered at Nimroud, which the recesses are well calculated to contain. These tombs must once have been closed; now they have small doors and even windows; those in the large tablet are numerous, and give the idea of a church. The whole cliff would have made an extremely pretty sketch. The windows of the large cave are close together in pairs, and arched. Being without a ladder, I could not get into them, and could not therefore ascertain whether they belonged to one large chamber, or to several adjoining chambers. I am inclined to think that the latter is the case. It would seem that these bas-reliefs covered royal tombs, with concealed entrances, which were, at a later period, broken open and pillaged, and afterwards converted into dwellings, and the windows opened. It is possible that chambers still unrisfled might be found behind the smaller tablets. I suspect that the inscription has been injured by holes having been bored into it to make an opening, and that the attempt was subsequently abandoned. There are various signs and religious emblems scattered about—chiefly representations of the sun and moon." It is to be regretted that Mr. Ross was unable to take a copy of the inscription, which would probably have enabled me to ascertain the comparative epoch of the tablets, with reference to the ruins of the Assyrian palaces. His suggestion, with regard to these bas-reliefs marking places of sepulture, is well deserving of attention. It is possible that I may, at some future period, be able to examine these rock sculptures with the attention they deserve, and to determine their use. At present there is reason to believe that the chambers belong to a more recent period than the Assyrian bas-reliefs; but their date has not been satisfactorily determined, and they may after all have been what Mr. Ross conjectures.

evidence of that magnificence and power which made Nineveh the wonder of the ancient world, and her fall the theme of the prophets, as the most signal instance of divine vengeance. Without the evidence that these monuments afford, we might almost have doubted that the great Nineveh ever existed, so completely "has she become a desolation and a waste."

Before my departure I was desirous of giving a last entertainment to my workmen, and to those who had kindly aided me in my labors. On the western side of Kouyunjik there is a small village. It belongs, with the mound, to a former slave of a Pasha of the Abd-el-Jelleel family, who had received his liberty, and the land containing the ruins, as a reward for long and faithful services. This village was chosen for the festivities, and tents for the accommodation of all the guests were pitched around it. Large platters filled with boiled rice, and divers inexplicable messes, only appreciated by Arabs, and those who have lived with them,—the chief components being garlic and sour milk,—were placed before the various groups of men and women, who squatted in circles on the ground. Dances were then commenced, and were carried on through the greater part of the night, the Tiyari and the Arabs joining in them, or relieving each other by turns. The dancers were happy and enthusiastic, and kept up a constant shouting. The quiet Christian ladies of Mosul, who had scarcely before this occasion ventured beyond the walls of the town, gazed with wonder and delight on the scene; lamenting, no doubt, that the domestic arrangements of their husbands did not permit more frequent indulgence in such gayeties.

At the conclusion of the entertainment I spoke a few words to the workmen, inviting any who had been wronged, or ill-used, to come forward and receive such redress as it was in my power to afford, and expressing my satisfaction at the successful termination of our labors without a single accident. One Sheikh Khalaf, a very worthy man, who was usually the spokesman on such occasions, answered for his companions

They had lived, he said, under my shadow, and, God be praised, no one had cause to complain. Now, that I was leaving, they should leave also, and seek the distant banks of the Khabour, where at least they would be far from the authorities, and be able to enjoy the little they had saved. All they wanted was each man a teskerè, or note, to certify that they had been in my service. This would not only be some protection to them, but they would show my writing to their children, and would tell them of the days they had passed at Nimroud. Please God, I should return to the Jebour, and live in tents with them on their old pasture grounds, where there were as many ruins as at Nimroud, plenty of plunder within reach, and gazelles, wild boars, and lions for the chase. After Sheikh Khalaf had concluded, the women advanced in a body and made a similar address. I gave a few presents to the principal workmen and their wives, and all were highly satisfied with their treatment.

A few days afterwards, the preparations for my departure were complete. I paid my last visit to Essad Pasha, called upon the principal people of the town, and on the 24th of June was ready to leave Mosul.

I was accompanied on my journey to Constantinople by Mr. Hormuzd Rassam, Ibrahim Agha, and the Bairakdar, and by several members of the household of the late Pasha; who were ready, in return for their own food and that of their horses, to serve me on the road. We were joined by many other travellers, who had been waiting for an opportunity to travel to the north in company with a sufficiently strong party. The country was at this time very insecure. The Turkish troops had marched against Beder Khan Bey, who had openly declared his independence, and defied the authority of the Sultan. The failure of the crops had brought parties of Arabs abroad, and scarcely a day passed without the plunder of a caravan and the murder of travellers. The Pasha sent a body of irregular horse to accompany me as far as the Turkish camp, which I wished to visit on my way. With this escort, and with my own party, all well armed and prepared to defend

themselves, I had no cause to apprehend any accident by the way.

Mr. and Mrs. Rassam, all the European residents, and many of the principal Christian gentlemen of Mosul, rode out with me to some distance from the town. On the opposite side of the river, at the foot of the bridge, were the ladies who had assembled to bid me farewell. Beyond them were the wives and daughters of my workmen, who clung to my horse, many of them shedding tears as they kissed my hand. The greater part of the Arabs insisted upon walking as far as Tel Kef with me. In this village supper had been prepared for the party. Old Gouriél, the Kiayah, still rejoicing in his drunken leer, was there to receive us. We sat on the house-top till midnight. The horses were then loaded and saddled. I bid a last farewell to my Arabs, and started on the first stage of our long journey to Constantinople.

PART II.

CHAPTER I.

I HAVE endeavored, in the preceding pages, to describe the manner in which excavations were carried on amongst the ruins of Nineveh, and the discoveries to which they gave rise. At the same time, I have sought to convey to the reader, by short descriptions of the Chaldæans, the Arabs, and the Yezidis, some idea of the people, who are now found within the limits of the ancient kingdom of Assyria Proper. This account of my labors would, however, be incomplete, were I not to point out the most important of their results; were I not to show how far the monuments and remains discovered tend to elucidate disputed questions of history or chronology, or to throw light upon the civilization, manners, and arts of a people, so little known as the Assyrians. It must, however, be remembered that our materials are as yet exceedingly incomplete. The history of this remarkable nation, as derived from its monuments, is a subject hitherto left untouched; and indeed within a very few months alone, have we possessed any positive data to aid us in such an inquiry. The meagre, and mostly fabulous, notices scattered through the works of ancient writers, scarcely afford us any aid whatever; for Nineveh had almost been forgotten before history began. The examination of remains existing on the banks of the Tigris has been but limited. Many extensive ruins are yet unexplored, and it can scarcely be doubted that there are still mounds inclosing records and monuments, the recovery of which would add greatly to our acquaintance with this long-lost people.

Only three spots have been hitherto examined, Nimroud, Kouyunjik and Khorsabad ; and of the three, Khorsabad, the smallest, alone thoroughly. Unfortunately in the Assyrian edifices, little but the sculptured slabs has been preserved. All the painted records which once covered the walls, in addition to the bas-reliefs of alabaster, have perished. Nor have we, as in Egypt, labyrinths of tombs, on the sides of which, as well as on the walls and columns of the temples, are most faithfully and elaborately portrayed the history, the arts, the manners, and the domestic life of the former occupiers of the land—so fully indeed, that, from these monuments alone, we are able to obtain a complete insight into the public and private condition of the Egyptians, from the remotest period to their final extinction.* Hitherto, no tombs have been discovered in Assyria, which can, with any degree of certainty, be assigned to the Assyrians themselves. It is not impossible that such tombs, even painted after the fashion of the Egyptians, do exist in the bosom of some unexplored hill ; their entrances so carefully concealed, that they have escaped the notice of the subsequent inhabitants of the country. At present, however, the only sources from which we can obtain any knowledge of Assyria, are the bas-reliefs discovered in the ruins described in the previous pages. To these may be added a few relics, such as seals, and cylinders, and one or two inscriptions on stones, bricks, and tiles, to be found in the Museums of Europe. Still the sculptures do furnish us with very interesting and important details, both with regard to the arts, and to the manners of the Assyrians ; and there is every reason to presume that the inscriptions, when deciphered, will afford positive historical

* I need scarcely mention the admirable work of Sir Gardner Wilkinson, in which he has availed himself of the paintings, sculptures, and monuments of the ancient Egyptians to restore their manners and customs, and to place their public and private life before us, as fully as if they still occupied the banks of the Nile. I shall frequently have occasion to refer to it in the course of this and the following chapters.

data, which may enable us to fix, with some confidence, the precise period of many events recorded in the bas-reliefs.

There are also other subjects, connected with the discoveries in Assyria requiring notice. Through them may be traced the origin of many arts, of many myths and symbols, and of many traditions afterwards perfected, and made familiar to us through the genius of the Greeks. The connection between the East and the West, and the Eastern origin of several nations of Asia Minor, long suspected, may perhaps be established by more positive proof than we have hitherto possessed. These considerations alone require a detailed account of the results of the excavations. I have endeavored to avoid statements which do not appear to be warranted by plausible evidence; and if I have ventured to make any suggestions, I am ready to admit that the corroboration of my views must depend upon an acquaintance with the contents of the inscriptions, and upon the future examination of ruins, in which additional monuments may exist.

As I have frequently alluded to the remote antiquity of the Assyrian edifices, it will naturally be asked upon what grounds we assign them to any particular period—on what data do the proofs of their early origin rest? In answering these questions, it will be necessary to point out the evidence afforded by the monuments themselves, and how that evidence agrees with the statements of ancient authors.

From our present limited knowledge of the character used in the inscriptions, and from a want of adequate acquaintance with the details of Assyrian art, which might lead to a satisfactory classification of the various remains, we can scarcely aim at more than fixing a comparative epoch to these monuments. It would be hazardous to assign any positive date to them, or to ascribe their erection to any monarch whose name can be recognized in any dynastic list of acknowledged authenticity, and the time of whose reign can be determined with any pretence to accuracy. Although a conjecture may be allowed, we can come to no positive conclusion upon the sub

ject. More progress is required in deciphering the character, more extensive researches must be carried on amongst the ruins of Assyria, and names of kings must be ascertained, by which we may connect the genealogical lists, undoubtedly of various epochs, that have hitherto been discovered. I will only point out facts which prove that the edifices described in the previous pages must belong to a very early period, without pretending to decide their exact age. The inquiry is one of considerable importance, for upon its results depend many questions of the highest interest connected with the history of civilization, in the countries watered by the Tigris and Euphrates, of its passage into the neighboring kingdoms, and of its ultimate effects upon the more distant regions of Asia, and even upon Greece.

The proofs to be adduced in support of the great antiquity of some of the monuments of Nimroud, are entitled to attention, and should not be rejected, merely because they are at variance with preconceived notions and theories. We are not justified in attempting to draw conclusions from the state of the arts, or sciences, amongst a people of whose history and capabilities, before the discovery of these monuments, we were totally ignorant. We knew nothing of the civilization of the Assyrians, except what could be gathered from casual notices scattered through the works of the Greeks. From their evidence, indeed, we are led to believe that the inhabitants of Assyria had attained a high degree of culture at a very remote period. The testimony of the Bible, and the monuments of the Egyptians, on which the conquests of that people over Asiatic nations are recorded, lead to the same conclusion. It will be shown, that in Assyria, as in Egypt, the arts do not appear to have advanced, after the construction of the earliest edifices with which we are acquainted, but rather to have declined. The most ancient sculptures we possess are the most correct and severe in form, and show the highest degree of taste in the details. The very great antiquity of the early monuments of Egypt, however much we may differ between

the highest and lowest date claimed for them, is now generally admitted. Few persons indeed would be inclined to ascribe them to a later epoch than that generally assigned to the foundation of Nineveh, about twenty centuries before Christ. At that time the arts had attained a very high degree of perfection in Egypt; and might obviously have attained even to a much higher, had not those who practised them been restricted by certain prejudices, and superstitions, to a conventional style, from which it was not lawful to depart. There is no reason to doubt, therefore, that at the same remote period, the Assyrians also may have excelled in them. Even the conventional forms of Egypt are accompanied by extreme beauty in the details, and in the shape of the domestic furniture and utensils; which proves that those who invented them were capable of the highest culture, and, if unfettered, might have attained to the greatest perfection. The Assyrians may not have been confined to the same extent as their rivals; they may have copied nature more carefully, and may have given more scope to their taste, and invention, in the choice and arrangement of their ornaments. But the subject will be more fully entered into when I come to speak of the arts of the Assyrians.* We have now to examine the evidences of the antiquity of their monuments.

The first ascertained date from which our inquiry must commence, is the destruction of Nineveh by the combined armies of Cyaxares, King of Persia and Media, and Nabopolassar, King of Babylon, or more probably governor of that city on behalf of the Assyrian monarch. We must needs go backwards, as we cannot with any degree of certainty fix the date of any earlier event.

It must, I think, be readily admitted that all the monuments hitherto discovered in Assyria are to be attributed to a period

* These remarks are necessary, as there is an impression that an approximate date can be assigned to the monuments discovered at Nimroud from the style of art of the sculptures. (See a letter of Mr. Westmacott in the *Athenæum* of 7th August, 1847.)

preceding the Persian conquest. In the first place, history and tradition unite in affirming that Nineveh was utterly destroyed by the conquerors. Although the earlier prophets frequently allude to the great city, and to its wealth and power before its fall, it will be observed that the latter rarely mention the name. If they do, it is in allusion to the heap of ruins—to the desolation which was spread over the site of a once great city, as a special instance of the divine vengeance. They pointed to it as a warning to other nations against whom their prophecies were directed.* When Xenophon passed over the remains of Nineveh, its very name had been forgotten, and he describes a part of it as a deserted city which had formerly been inhabited by the Medes.† Strabo says, that when Cyaxares and his allies took the city, they utterly destroyed it; its inhabitants, according to Diodorus Siculus, being distributed in the surrounding villages. Lucian speaks of Nineveh as so completely laid waste, that even its vestiges did not remain.‡ It is certain that even if Nineveh were not levelled with the ground, or deserted by its inhabitants, it was no longer the seat of government, nor held a high place amongst the cities of the East. If vast palaces and edifices are found amongst its ruins, it is much more reasonable to refer their construction to a period when Nineveh was the capital of the Eastern world, and the dwelling-place of the Assyrian monarchs, than to the time of its subjection to the kings of Persia, and of its degradation to a mere provincial town.

If these edifices—between the periods of the erection of which many years, even centuries, must have elapsed—were

* See particularly Ezekiel, ch. xxxi.

† Cyrop. l. iii. c. 4.—“After this defeat the Persians retired, and the Greeks, marching the rest of the day without disturbance, came to the river Tigris, where stood a large uninhabited city, called Larissa, anciently inhabited by the Medes.”

‡ Strabo, lib. xvi. Herodotus appears to allude to it as a city that formerly existed. (Lib. i. c. 193.) Clement of Alexandria, in his commentaries on Nahum, confirms the account of Lucan of its utter destruction. The Nineveh of Tacitus (Annal. l. xii. 13) and Ammianus Marcellinus (l. xviii. c. 7), was a modern city built near or on the ruins of the ancient.

the work of the Persian conquerors, we should find some record of the fact. The peculiar variety of the cuneiform character adopted by the Persians is perfectly well known, and is found on all their monuments. It was even used in Egypt, accompanied by hieroglyphics, after their conquest of that country.* It occurs on all the monuments of the same period in Persia and Armenia, accompanied by translations, in parallel columns, in the Babylonian and Median† writing. Amongst the ruins of Assyria, this Persian variety of the cuneiform character had never been found. It can scarcely be doubted, that the bas-reliefs described in the previous pages, represent the victories and conquests of the kings who built the edifices in which they were contained; it is not probable that, had these kings been Persians, they would have omitted to record their deeds in their native tongue, when they have done so in all other places where they have caused similar monuments to be erected.

The date of the conquest of Nineveh by Cyaxares is well ascertained as 606 before Christ.‡ The city had then been

* I allude to the vases with the names of the Persian kings in hieroglyphics, as well as in cuneiform characters. One at Venice bears the name of Artaxerxes; that usually known as Caylus's vase, in the National Library, at Paris, the name of Xerxes.

† I use the term Median, however inapplicable, because it has generally been adopted.

‡ The evidence afforded as to the exact date of the destruction of Nineveh by the concurrent evidence of Scripture and Herodotus, is thus collected by Clinton (*Fasti Hellenici*, vol. i. p. 269): "The overthrow of Nineveh did not happen before the death of Josiah king of Judah in B. C. 609, because a king of Assyria is mentioned at that period; and Zephaniah, in the prophecy delivered in the reign of Josiah, predicts the destruction of Nineveh as a future event. The sum of the argument is this: From the age of Tobit it appears that Nineveh was standing in B. C. 610. For he became blind in the year 710, and survived that accident 100 years; and yet he died before the fall of Nineveh. But a prophecy of Jeremiah, written in the first year of the captivity, B. C. 605, seems to imply that the city was then destroyed; for in the particular enumeration of all the kings of the north far and near, and all the kingdoms of the world, &c., Assyria and Nineveh are not named. The testimony of Scripture, then, decides that the city was captured, and the Assyrian monarchy destroyed, certainly after B. C. 609, and probably before B. C.

scarcely a year in the hands of the Assyrians, after the expulsion of the Scyths, who, according to the testimony of Herodotus, held this part of Asia for twenty-eight years. We cannot attribute these vast monuments—evidences of a high state of civilization, and of taste and knowledge—to the wandering tribes; who, during their short occupation, did little, according to the historian, but oppress the inhabitants, pass their days in licentiousness amidst new luxuries, and destroy the records of former prosperity and power.* We have consequently the date of 634 years before Christ to go back from. No one will, I think, be inclined to assign these edifices to a later epoch.

It has already been seen that there are buildings of various periods in the mound of Nimroud, and I have mentioned that they contain the names and genealogies of several kings. The most recent palace was that discovered in the southwest corner; and it was principally built of slabs and materials taken from the edifices in the northwest, the centre, and other parts of the mound. This can be proved beyond a question; first, by identity in the style of the sculptures; secondly, by inscriptions, in which certain formulæ occur; thirdly, by the fact of the sculptured faces of the slabs being turned *against* the wall of sun-dried bricks, and smoothed on the opposite side preparatory to their being used a second time; and, fourthly, by the discovery of sculptured slabs lying in different parts of the

605. Herodotus brings the date to a narrower point. Cyaxares prepared to revenge his father's death upon the Assyrians, but was interrupted by the Scythians, who held Asia for twenty-eight years. After their expulsion Cyaxares conquered the Assyrians. But as the Scythians were not expelled till b. c. 607, the capture of Nineveh could not occur till b. c. 606; and this date, obtained from Herodotus, is remarkably consistent with the accounts of Scripture." According to the Seder-Olam (c. 24, 25), the fall of Nineveh would have occurred about this time; and upon its authority M. Freret (Mem. de Lit. tirés des Registres de l'Académie, vol. vii. p. 538) places the event in 608 b. c.

* "After possessing the dominion of Asia for twenty-eight years, the Scythians lost all they had obtained by *their licentiousness and neglect*."—Herod. lib. i. c. 106.

ruins, where they had evidently been left, whilst being removed to the new palace.

The only sculptures which can be attributed to the builders of this edifice are the bulls and lions forming the entrances, and the crouching sphinxes between them. But the arguments they afford will be the same, whether they were the work of those who founded the building, or whether they were brought from elsewhere. If the latter be the case, we should be furnished with additional proof in favor of the high antiquity of the earliest edifice. In the material, a kind of limestone, out of which they are sculptured, as well as in certain peculiarities of form (as, for instance, in being provided with four legs, and having small figures carved on the same slab), they differ from any others discovered amongst the ruins. It is not probable that they could have been moved in their finished state without injury; and, as it will be hereafter shown, it was evidently the custom of the Assyrians to sculpture their slabs, not before, but after they had been placed.

On the backs of these lions and bulls we have a short, but highly important, inscription, which has enabled me, as I have already had occasion to observe, to identify the comparative date of many monuments discovered in Assyria, and of tablets existing in other parts of Asia. Before submitting this inscription, as well as others from the ruins, to the reader, I must describe the process by which the names of the kings have been determined; as the arguments will mainly depend upon the proof which these names afford.

Two characters appear at one time to have been in use amongst the Assyrians: One, the cuneiform or arrow-headed, as in Egypt, was probably the hieroglyphic, and principally employed for monumental records;* the other, the cursive or hieratic, may have been used in documents of a private nature, or for records of public events of minor importance. The

* Democritus is said to have written on the *sacred* letters of Babylon "τὰ περὶ τῶν ἐν Βαβυλῶν ἱερῶν γραμμάτων." (Diog. Laert. lib. ix.) This appears to point to two forms of writing.

nature of the arrow-headed will be hereafter fully described. The cursive resembles the writing of the Phœnicians, Palmyrenes, Babylonians, and Jews; in fact, the character, which, under a few unessential modifications, was common to the nations speaking cognate dialects of one language, variously termed the Semitic, Aramæan, or, more appropriately, Syro-Arabian. There is this great distinction between the cuneiform and cursive,—that while the first was written from left to right, the second, after the fashion of the Hebrew and Arabic, ran from right to left. This striking difference would seem to show that the origin of the two modes of writing was distinct.*

It would be difficult, in the present state of our knowledge, to determine the period of the invention and first use of written characters in Assyria; nor is there any evidence to prove which of the two forms, the arrow-headed or the cursive, is the more ancient, or whether they were introduced at the same time. Pliny declares that it is to the Assyrians we owe the invention of letters, although some have attributed it to the Egyptians, who were said to have been instructed in the art of writing by Mercury;† or to the Syrians, who, in the passage in Pliny, are evidently distinguished from the Assyrians, with whom they are by ancient authors very frequently confounded.‡ Lucan ascribes their introduction to the Phœnicians, a Syrian people.§ On monuments and remains purely

* The numerals, like the letters, were expressed by various combinations of the wedge. There appear to have been, at the same time, numbers for the cursive, as well as for the cuneiform writing, the former somewhat resembling the Egyptian. On the painted bricks of Nimroud I could, I think, trace several of these cursive numerals, each brick having apparently a number upon it. Dr. Hincks was, I believe, the first to determine the forms and values of the Assyrian numerals by an examination of the inscriptions of Van.

† This deity, under the name of Thoth, or Taut, was the Egyptian god of letters

‡ “*Literas semper arbitrator Assyrias fuisse; sed alii apud Ægyptios à Mercurio, ut Gellius: alii apud Syros repertas volunt.*”—*Pliny*, lib. vii. c. 57.

§ “*Phœnices primi famæ si creditur aasi*

Mansuram rudibus vocem signare figuris.”—*Lib. iii. v. 230.*

Syrian, or such as cannot be traced to a foreign people, only one form of character has been discovered, and it so closely resembles the cursive of Assyria, that there appears to be little doubt as to the identity of the origin of the two. If, therefore, the inhabitants of Syria, whether Phœnicians or others, were the inventors of letters, and those letters were such as exist upon the earliest monuments of that country, the cursive character of the Assyrians may have been as ancient as the cuneiform. However that may be, this hieratic character has not yet been found in Assyria on remains of a very early epoch, and it would seem probable that simple perpendicular and horizontal lines preceded rounded forms, being better suited to letters carved on stone tablets or rocks. At Nimroud, the cursive writing was found on part of an alabaster vase, and on fragments of pottery, taken out of the rubbish covering the ruins. On the alabaster vase it accompanied an inscription in the cuneiform character, containing the name of the Khorsabad king, to whose reign it was evident, from several circumstances, the vase must be attributed. It has also been found on Babylonian bricks of the time of Nebuchadnezzar. The following are parts of inscriptions in this character on fragments of pottery from Nimroud.

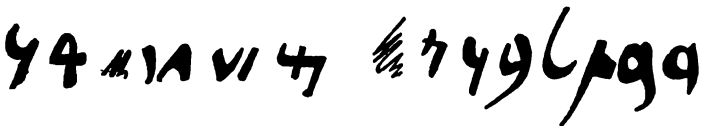

The cuneiform, however, appears to have been the character in general use in Assyria and Babylonia, and at various periods in Persia, Media, and Armenia. It was not the same in all these countries; the element was the wedge, but the combination of wedges, to form a letter, differed. The cuneiform has been divided into three branches; the Assyrian or Babylonian; the Persian; and a third, which has been named, probably with little regard to accuracy, the Median. To one of these three divisions may be referred all the forms of arrow-

headed writing with which we are acquainted; and the three together occur in the trilingual inscriptions, containing the records of the Persian monarchs of the Achæmenian dynasty.* These inscriptions are, as it is well known, repeated three times on monuments of this period, in parallel columns or tablets, in a distinct variety of the arrow-headed character; and, as it may be presumed, in a different language.

The investigation of the Persian branch of the cuneiform has now, through the labors of Rawlinson, Lassen, and others, been brought to a satisfactory conclusion. I presume that there are few unacquainted with the admirable memoirs by Major Rawlinson upon the great inscription at Behistun,† published in the *Journal of the Royal Asiatic Society*. Some, however, are still inclined to look upon the results of his labors with doubt, and even to consider his translation as little more than an ingenious fiction. That the sudden restoration of a language no longer existing in the same form, and expressed in characters previously unknown, should be regarded with considerable suspicion, is not surprising. But even a superficial examination of the ingenious reasoning of Professor Grotefend, which led to the first steps in the inquiry, the division of words and the discovery of the names of the kings, and an acquaintance with the subsequent discoveries of Rawlinson and other

* Major Rawlinson has suggested the use of the term Scythic instead of Median (the Persian Cuneiform Inscription at Behistun deciphered, part i. p. 20, vol. x. of the *Journal of the Royal Asiatic Society*). However, until the language of the inscriptions in this character can be determined beyond a doubt, we can scarcely venture upon adopting definitively either appellation. Major Rawlinson is of opinion that that language is a Scythic or Mongolian dialect; and from its use on monuments erected by the Persian kings, it is highly probable that it is so. The subjects of the Achæmenian monarchs included three great divisions of the human race, speaking respectively Semitic or Syro-Arabian, Indo-European or Arian, and Scythic or Mongolian languages; and when we find that two of the columns of the trilingual inscriptions are dialects of the first and second of these languages, we may consistently infer that the remaining version of the inscriptions is in the third.

† This name is generally written Bisutun in the maps; it is now given to a small village near Kirmanshah, on the frontiers of Persia.

eminent philologists, must at once remove all doubt as to the general accuracy of the results to which they have arrived. There may undoubtedly be interpretations, and forms of construction open to criticism. They will probably be rejected or amended, when more materials are afforded by the discovery of additional inscriptions, or when those we already possess have been subjected to a still more rigorous philological examination, and have been further compared with known dialects of the same primitive tongue. But as to the general correctness of the translations of the inscriptions of Persepolis and Behistun, there cannot be a question.* The materials are in every one's hands. The inscriptions are now accessible, and they scarcely contain a word the meaning of which may not be determined by the aid of dictionaries and vocabularies of the Sanscrit and other early Indo-European languages.†

Before the publication of the great inscription of Behistun, the monuments of Persia, containing little more than the names of kings and royal titles, afforded few materials for the investigation of cuneiform writing. That inscription was long known, and had been seen by many travellers. MM. Coste and Flandin, who accompanied M. de Sercey during his embassy to the court of Teheran, for the express purpose of examining and making drawings of ancient remains, were particularly directed to copy it. They lingered many days

* The transcription in cuneiform letters of a hieroglyphical legend on a vase at Venice, is a test of the general accuracy of the deciphering of both characters. The name of the king was found to be that of Artaxerxes, and was so read independently from the Persian and Egyptian texts, by Major Rawlinson and Sir Gardner Wilkinson.

† There is not a more attractive subject of investigation, nor one more delusive and uncertain in its results, unless carried on with the most rigorous regard to criticism, than the origin, derivation, and connection of languages. But whilst this is admitted, it must be remembered, that within the last few years this branch of study has been greatly facilitated by the discovery of rules, which are now generally recognized. They go far to guide those who engage in the inquiry, and to prevent a repetition, of the absurd speculations of the last century. Etymology may now take its place amongst the sciences, and no science is more important in any investigation connected with the history of the human race.

on the spot, making several fruitless endeavors to ascend to that part of the rock on which it is cut. At length they declared it to be inaccessible, and returned to France without this important historical record. Major Rawlinson, however, overcame all difficulties. During two visits he succeeded in copying all that remains of the three versions of the inscription; and thus, whilst we are indebted to his intrepidity and perseverance for the transcript of the record, we owe to his learning and research the translation of one of the most interesting fragments of ancient history.*

Of the second, or so called Median branch of the cuneiform, we know at present but little. It differs essentially, in the combination of the wedges, from the Persian, and resembles in many respects the Assyrian or Babylonian, many letters in both being identical in shape, if not in phonetic power.

Whilst the Persian and Median cuneiform offer each but one modification in the arrangement of the wedges, the third division, or Assyro-Babylonian, includes several varieties. It has been said to be the most complex in its forms of the three; but such is not exactly the case, as we have in the varieties both extremes: the primitive, or early Assyrian, containing the most simple and elementary combinations, beginning with the wedge standing alone, whilst the Babylonian is distinguished by the most intricate and complex. However, that the two are identically the same, has been proved beyond a doubt by a comparison of the monuments of Babylonia and Assyria, and by the existence of a transcript of a Babylonian record in Assyrian characters.† The variations appear to be mere cali-

* The contents of the Behistun inscription are of great importance to all interested in the study of ancient history, as they so fully confirm the statements of Herodotus, and afford fresh proofs of his veracity and accuracy.







† I particularly refer to the fragment of a cylinder given in vol. ii. of Ker Porter's Travels, and the celebrated inscription in the India House, supposed to contain the decrees of Nebuchadnezzar, of which the cylinder, when entire, appears to have been a transcript. Their identity was, I believe, discovered by Grotefend. It is on the tablets and cylinders of baked clay, that the Assyrian cuneiform character

graphical distinctions, and were purposely made, to mark the difference between the characters in use in the two countries. The introduction of a few complex forms in the pure Assyrian writing, may be attributed to the number of alphabetic signs required. The alphabet of the Persian cuneiform contains but thirty-nine or forty letters; in the Assyro-Babylonian inscriptions there are about three hundred different characters; the simpler forms would consequently soon be exhausted.*

Major Rawlinson has thus classed the Assyro-Babylonian cuneiform writing:—Primitive Babylonian; Achæmænian Babylonian; Medo-Assyrian; Assyrian; and Elymæan.

Whilst concurring in this division I would suggest, that early Assyrian and later Assyrian be substituted for Assyrian and Medo-Assyrian. By Medo-Assyrian, Major Rawlinson indicates the character used in the inscriptions of Van, belonging to a period preceding the Persian domination,† and in those at Palou,‡ and near Malatia, on the banks of the Euphrates. But at the time he made the distinction he was unacquainted with the earliest monuments of Nimroud, and had only examined inscriptions from Khorsabad, and a fragment from Nimroud, both belonging to the same period. The most ancient Assyrian letters are identical in form with those found in Armenia. The distinction lies between the earliest and latest Assyrian writing, and is amply sufficient to determine

is most complex. Besides the substitution of forms not used on the monuments, common letters are rendered more intricate by adding to the number of wedges:—

thus  becomes   , and   .



* Many of these characters are undoubtedly what are termed "variants," that is, merely a different way of forming the same letter; but even admitting a large number to be so, and to be interchangeable arbitrarily, still there are between 100 and 150 letters which appear to have each their distinct phonetic value.

† There is also a trilingual inscription of Xerxes on the rock at Van.

‡ The inscription at Palou, an ancient Armenian city, was first examined and copied by me on my return from Mosul last year. My attention was called to it by Dr. Smith, of the American Board of Foreign Missions. It closely resembles the inscription near Malatia, copied by Captain Van Mühlbach. (See Papers of the Syro-Egyptian Society, vol. i. part i.)

the comparative date of monuments, as the shape of our own letters marks the time of a document.

The primitive Babylonian is found on bricks, cylinders, and tablets from ruins in Babylonia; the Achæmænian Babylonian in the trilingual inscriptions of Persia. The former is well known from its frequent occurrence on relics, brought to this country, from the remains on the Euphrates near the modern Arab town of Hillah, hitherto believed to be those of primitive Babylon. It is the most intricate variety of the cuneiform yet discovered. Those who used it appear to have exhausted their ingenuity in complicating the simplest forms of the Assyrians.

By a comparison of many letters of the same power in the Assyrian and Babylonian alphabets, it is evident that their dissimilitude frequently arises from the manner of shaping the elementary wedge, either angle of which might be elongated according to the fancy of the writer or sculptor. Thus Υ becomes \lrcorner or \llcorner , and the simple Assyrian letter  is identical with , a character of common occurrence in Babylonian inscriptions.

With regard to the relative antiquity of the several forms of cuneiform writing, it may be asserted, with some degree of confidence, that the most ancient hitherto discovered is the Assyrian. The three varieties found in the trilingual inscriptions are all of a comparatively recent period, the reigns of the Achæmænian dynasty. The inscriptions in the Babylonian character, from the ruins near Hillah, can be shown to belong to the time of Nebuchadnezzar, and consequently to a period subsequent to the fall of the Assyrian empire. The name of that monarch is found upon them all. Amongst the ruins of Niffer, to the south of Hillah, Major Rawlinson has discovered other inscriptions with a new royal name; but it is uncertain to what period they belong. That eminent antiquary, who was, I believe, the first to identify the name of Nebuchadnezzar on the bricks and tablets, from the ruins so long believed

to be those of the scriptural Babylon, inclines to the opinion that Niffer may represent its true site, whilst the mounds around Hillah are the remains of a more recent city of the same name.* Nor is this supposition of the existence of two Babylons inconsistent with history, and Eastern customs. Nebuchadnezzar declares that he built the city. "At the end of twelve months he walked in the palace of the kingdom of Babylon. The king spake, and said, '*Is not this great Babylon that I have built* for the house of the kingdom, by the might of my power, and for the honor of my majesty?'"† After the successful revolt of the Babylonians, and the fall of Nineveh, it is not improbable that Nebuchadnezzar, on founding a new empire which was to rival the Assyrian in power and extent, should have desired to build a capital worthy of it. During the Assyrian supremacy, the ancient capital of the Chaldæans may have partly fallen into ruins; and it was perfectly in accordance with the customs and prejudices of an Eastern people, to choose for rebuilding it a new site not far removed from

* None of the ruins in Babylonia have yet been properly examined, and there is little doubt that excavations in them would lead to very interesting results. The great obelisk ascribed to Semiramis, by Diodorus Siculus, may have been the pillar or column of Acicarus, seen and interpreted by Democritus in his travels in the commencement of the 4th century B. C. (Laertius, in *Vita Democriti*, p. 650, ed. Casaubon, and Clemens Alexandrinus *Stromata*, lib. i. cxv. s. 69.) It was, there can be little doubt, a Babylonian monument; and it probably still exists somewhere in the ruins. Major Rawlinson, in a recent letter, informs me that, according to the Arabs, an obelisk has been seen at Niffer, and such reports have generally some foundation, as I have shown with regard to the sitting figure of Kalah Sherghat (see Chap. XII.). It may have been exposed to view for a short period, and have again been covered up by rubbish. Major Rawlinson is of opinion that all the most ancient remains of Chaldæa (previous to the reign of Nebuchadnezzar) must be looked for in the ruins to the south of Hillah, in southern Babylonia; those to the north being chiefly referable to that king. I have visited most of the remains in the province; but too hastily, and at times of too great danger to admit of a careful and prolonged examination. With proper means and support, researches might, however, be carried on.

† Daniel iv. 29. Josephus (cont. Ap. l. i.), quoting Berosus, says that Nebuchadnezzar repaired the city of Babylon which then existed, and added another city to it.

the old. Babylon affords more than one instance of this very custom. The successor of Alexander the Great in the empire of the East, seeking for a capital, did not rebuild Babylon, which had again fallen into decay. He chose a site near it on the banks of the Tigris, founded a new city, calling it Seleucia, after his own name, and partly constructing it out of materials taken from Babylon. Subsequently, when another change of dynasty took place, the Parthian succeeding to the Greek, the city was again removed, and Ctesiphon rose on the opposite side of the river. After the Persians came the Arabs, who, desiring to found a capital for their new empire, chose a different site; still, however, remaining in the vicinity of the old. Changing the locality more than once they at length built the celebrated city of Baghdad, which actually represents the ancient Babylon.* Such appears to have been the general practice in the East; and there is scarcely a place of any note which has not been rebuilt on a different site. The present inhabitants of the country, whether Turks or Arabs, either aware of this fact, or still laboring under the prejudices of the former people, generally seek in the neighborhood of a modern town some ancient remains, to which they attach the same name.†

It is probable, however, that the half-fabulous accounts of the walls, palaces, temples, and bridges of Babylon, whose foundation was attributed by Herodotus, Diodorus Siculus, and other ancient authors, to two queens, Semiramis and Nitocris, related to the edifices of the second Babylon, built by Nebuchadnezzar. The Chaldees still nourished the traditions of their ancient greatness, and may have endeavored, in satisfying the curiosity of a stranger, to assign the highest antiquity to their monuments.

* Baghdad is frequently called Babylon by the early travellers, and even by the Arab geographers. The Church of Rome still gives the title of "Bishop of Babylon" to the prelate who is placed over the Roman Catholic Christians in the Pashalic of Baghdad.

† Thus, there is Mosul and Eski (old) Mosul, Baghdad and Eski (old) Baghdad, &c., &c.

It may be asked what proof have we that the name of Nebuchadnezzar exists on bricks, and fragments, from the ruins near Hillah? The name, written nearly as in our version of the prophecies of Ezekiel, appears to have been assumed by one of the rebels subdued by Darius Hystaspes. It consequently occurs in the trilingual inscription of Behistun. One Natitabires is there stated to have called himself *Nabokhodrossor*, the son of Nabonidus, the King of Babylon. As these names are transcribed in the Babylonian column, there is of course no difficulty in recognizing the letters composing them, and hence their identification when found elsewhere, as at Hillah, in the pure Babylonian writing. In inscriptions from that site, Nebuchadnezzar is called the son of Nabonassar, and king of the land of the Chaldees.*

Although Major Rawlinson has suggested a reading for the name on the bricks from Niffer, it is doubtful to what period they belong; and at present there is no evidence to show that they are older than the most ancient edifice of Nimroud. We may, therefore, fairly assume that the Assyrian is the earliest known form of the arrow-headed writing. The complex shapes of the Babylonian characters, and their apparent derivation by elongation of angles and other processes from the simpler Assyrian letters, undoubtedly point to a more recent invention. There cannot be a doubt that the characters as formed in the earliest palace of Nimroud long preceded those of the inscriptions of Khorsabad and Kouyunjik. This is an

* An extraordinary laxity in the use, omission, and interchange of certain consonants, as it will be shown, is one of the distinguishing features of the language expressed by this branch of the cuneiform character. The name of Nebuchadnezzar is written in many ways—in the Bisutum inscription, we have *Nabokhodrossor*, *Nabukhadrachar*, and *Nabukhudrachar*. In pure Babylonian inscriptions it undergoes even more numerous changes. In Daniel he is called *Nebuchadnezzar*, or *Nabuchodonosor*; in Ezekiel (ch. xxvi. v. 7) the name is written *Nebuchadrezzar*. The first component of the word, *Nebo*, was the name of a Babylonian divinity. (Isaiah ch. xlvi. v. 1.) The interchanges which take place in consonants is shown by the names of several Babylonian kings, as given by the Greeks. Thus, the Labunitus of Herodotus is called *Nabunidus* by Berosus.

important fact, as it proves that the most simple were the earliest, and that there was a gradual progression towards the more intricate. This progression may be very clearly traced in the inscriptions from different Assyrian ruins. We may, therefore, consistently conclude that the Babylonian, being the most complex, was the most modern of this branch of cuneiform writing.

The question of prior antiquity now, therefore, lies between the monuments of Assyria, and the rock-tablets of Armenia. At present there is no positive evidence to decide their respective claims, but there are strong grounds for believing that the earliest inscriptions of Nimroud are the most ancient. We have the testimony of ancient authors, who attribute the invention of letters to the Assyrians, and give the name of Assyrian to the cuneiform writing, even when changed and modified by the Persians.* In the earliest inscriptions of Armenia, the royal titles resemble those of the first kings of Nimroud. In the latter inscriptions of the same Armenian dynasty, the titles are similar to those on the monuments of Khorsabad and Kouyunjik.† It may be inferred, therefore, that these Armenian kings lived between the erection of the earliest and latest monuments of Assyria proper. Whether there were contemporaneous Assyrian and Armenian dynasties, or whether the names at Van are those of kings who reigned at the same time over Armenia and Assyria, and are consequently to be included in the Assyrian dynastic lists, are questions which can only be determined when the contents of the inscriptions are known, and the ruins of Assyria more thoroughly examined.

Admitting, therefore, that the Assyrian is the most ancient known form of arrow-headed writing, it would be interesting



* Herodotus always calls this form of writing Assyrian. (See lib. iv. c. 87, &c.) According to Amyntas, the inscription on the tomb of Sardanapalus was written in Chaldean letters (*χαιδαϊκοῖς γράμμασιν*) on a stone column. Aristobulus terms them Assyrian letters. (Athenæus, lib. xii.) Also Arrian. (Exp. Alex lib. ii. c. 5.)

† This was brought to my notice by Major Rawlinson.

to ascertain its origin. The epithets of cuneiform, cuneatic, wedge-shaped, and arrow-headed, tête-à-clou (nail-headed) in French, and keilförmig in German, have been variously assigned to it, because its component parts resemble either a wedge, the barb of an arrow, or a nail, according to the fancy of the describer. It is not improbable, however, that the original or primitive elements of the letters were merely simple lines, the wedge or arrow-head being a subsequent improvement or embellishment. On a slab at Nimroud, forming a part of a wall in the southwest palace, but brought from the most ancient edifice, I found one line of writing in which the characters were thus formed. It occurred beneath the usual inscription, and was but slightly cut :—

𐎶𐎵𐎴𐎳𐎲𐎱𐎰𐎯𐎮𐎭𐎬𐎫𐎪𐎩𐎨𐎧𐎦𐎥𐎤𐎣𐎢𐎠𐎟𐎞𐎝𐎜𐎛𐎚𐎙𐎘𐎗𐎖𐎕𐎔𐎓𐎒𐎑𐎐𐎏𐎎𐎍𐎌𐎋𐎊𐎉𐎈𐎇𐎆𐎅𐎄𐎃𐎂𐎁𐎀

𐎶𐎵𐎴𐎳𐎲𐎱𐎰𐎯𐎮𐎭𐎬𐎫𐎪𐎩𐎨𐎧𐎦𐎥𐎤𐎣𐎢𐎠𐎟𐎞𐎝𐎜𐎛𐎚𐎙𐎘𐎗𐎖𐎕𐎔𐎓𐎒𐎑𐎐𐎏𐎎𐎍𐎌𐎋𐎊𐎉𐎈𐎇𐎆𐎅𐎄𐎃𐎂𐎁𐎀

It is evident that, by substituting the wedge, or arrow-head, for the lines in the above inscription, the characters would resemble such as are found on the earliest Assyrian monuments. The simpler letters may have been used in documents, and could have been written easily and quickly, whilst the more elaborate monumental character would require both time and care. In the inscriptions on Babylonian bricks the wedges are also frequently replaced by mere lines, as  for  or ,* these characters being the same. Nor is the element of the most ancient form of Assyrian monumental writing always the arrow-head or the wedge ; it sometimes assumes

* The character thus formed occurs in the inscriptions of Susiana. The Assyrian letter, of which the three variants in the text are modifications, has been given, p. 138.

the shape of a hammer on painted bricks from the earliest palace at Nimroud.



The use of the wedge may have been suggested by the impression of the angular corner of a square rod on a surface of soft clay, which will produce this form very accurately. Even complicated characters and a short inscription might thus have been impressed on a tablet of any soft material. But this elementary figure appears to have been sacred; for we find it represented as placed upon an altar, amongst other religious emblems, on a Babylonian relic, usually known as the "Caillou de Michaux," in the National Library of Paris. Whether it became sacred from its employment in the written character, or whether it was adopted as an emblem, I will not attempt to determine.*



Wedge or Arrow-head on an Altar. (From a stone in the Bibliothèque Nationale at Paris.)

* It would not be difficult for those who are apt at discovering the hidden meaning of ancient symbols, to invest the arrow-head or wedge of the inscriptions, assuming, as it frequently does, the form of an equilateral triangle, with sacred and mythic properties; and to find in it a direct illustration of the sacred triad, the basis of Chaldean worship and theogony, or of another well-known Eastern object of worship. (See Lajard's elaborate *Essays on the Worship of Venus*, on the Cy-

Nor will I stop to inquire whether, in their original forms, the Assyrian letters were ideographic; whether, as it has been assumed with regard to the alphabets of Syria, their names were derived from things which they were meant to represent. It will require a much more intimate acquaintance with the nature and powers of these characters than we can hope to attain for some time to come, before we can determine whether the arrangement of the wedges depends upon any system, or whether it be merely accidental. At present there is no proof in support of either supposition.

The first records of the Assyrians, like those of most ancient nations, were probably monumental. They were cut either on the walls of temples, palaces, and other edifices, or upon the smoothed face of a rock. After the subjection of a distant nation, the limits of the conquest of the king were marked, or his triumphs celebrated, by an inscription in some conspicuous spot in the conquered country. The side of a lofty precipice was generally chosen. A tablet was first cut sufficiently deep into the rock to leave above it a projecting ledge, to protect the sculpture as much as possible from the effects of the weather, and from the water which might run down its face. A bas-relief, representing the king alone, or the king receiving captives, was then generally sculptured. Below the figures, or near, was explained in writing the event recorded by the bas-relief, and sometimes a short inscription on the dress,* or above the head, of each person, contained his name and titles. Such is the Assyrian monument at the mouth of the Nahr-el-Kelb, or Dog River, in Syria. Frequently an inscription, or a bas-relief was alone carved, as in parts of Asia Minor. The rock below the tablet was generally scarped, all access to the monument being cut off, to save it

press, and on the Religious Symbols of the Assyrians and Persians, in the "Mémoires de l'Académie des Inscriptions et Belles Lettres," and in the "Annales de l'Institut Archéologique."

* Across the breast of the figures in Ionia, attributed by Herodotus (lib. ii. c. 106) to Sesostris, but which were probably Assyrian, was an inscription.

from injury or destruction. If no convenient rock could be found, or if the king wished to mark the boundaries of his dominions, a square pillar or slab was erected, as on the summit of the pass of Kel-i-Shin, in the high mountains dividing Assyria from Media.* The Persians, who appear to have closely imitated the Assyrians in all their customs, adopted the same method of recording their conquests and victories, as the rock sculptures of Behistun still testify. According to Herodotus, Darius in his Scythian expedition erected, on the shores of the Bosphorus, two columns of white marble, one having inscribed in Assyrian (cuneiform), and the other in Greek characters, the names of the different nations which composed his vast army. He placed a third on the Tearus, after crossing the straits into Thrace.†

When events were to be recorded more in detail, the inscriptions appear to have been engraved on the walls of their temples or palaces, as in Egypt, to accompany painted or sculptured representations of the scenes they described.

It is not improbable that during the early period of the Assyrian monarchy, stone and clay were the only substances on which private as well as public records were written. In the most ancient sculptures of Nimroud there are no representations of scribes. In the more recent, however, at Khorsabad, Kouyunjik, and Nimroud, we have eunuchs writing down the

* The custom of putting up tablets and pillars to fix the boundaries of an empire, is frequently alluded to in the monumental records of Egypt. (See Birch's Translation of the Obelisk at Constantinople, and Observations on the Statistical Tablet of Karnak, in the New Series of the Transactions of the Royal Society of Literature, vol. ii.)

† Herod. lib. iv. c. 87 and 91. This appears also to have been the most ancient method of chroniologing events and keeping records. Josephus, following an ancient tradition, declares that Seth erected in the land of Siriad, two pillars, one of brick, the other of stone, and inscribed upon them the principal antediluvian arts and sciences. (Antiq. Jud. lib. i. c. 3.) Sesostris, according to Herodotus, erected pillars and carved tablets in the places which he conquered. The Greek historian mentions those he had seen in Palestine (probably the tablets still existing near the Nahr-el-Kelb) and in Asia Minor. (Lib. ii. c. 102 and 106.)

number of heads, and the amount of spoil, on rolls of leather, or some other flexible material.*



Scribes writing down the number of heads of the slain and the amount of the spoil. (Konynjik.)

The material generally used cannot be determined from the sculptures. At the time of the close intercourse between Assyria and Egypt, probably existing, as it will be shown, at the period to which these bas-reliefs belong, the papyrus may have been an article of commerce between the two countries; or rolls of leather manufactured in Assyria may have been the only substance employed. The reed growing in the marshes formed by the Tigris and Euphrates may have served, as it does to this day, for a pen; and the cursive or hieratic characters, on the fragments of vases from Nimroud, appear to have been written with some such instrument.

But the most common mode of keeping records in Assyria and Babylonia was on prepared bricks, tiles, or cylinders of

* It could scarcely have been papyrus, as that substance is too brittle to be rolled or bent, as represented in the sculptures. Parchment was not invented until a much later period. Mr. Birch inclines to the idea of leather, which the Egyptians used occasionally as early as the 18th dynasty.

clay, baked after the inscription was impressed. The characters appear to have been formed by an instrument, or may sometimes have been stamped. The Chaldæan priests informed Callisthenes that they kept their astronomical observations on bricks baked in the furnace;* and we have the testimony of Epigenes to the same effect.† Ezekiel, who prophesied near the river Chebar in Assyria, was commanded *to take a tile* and portray upon it the city of Jerusalem.‡ Of such records we have many specimens. The most remarkable are two hexagonal cylinders, one in the possession of Colonel Taylor, late political agent at Baghdad, and the other given by me to the British Museum. They were both discovered in the ruins opposite Mosul, and, I believe, in the mound of Nebbi Yunus.§ On each side there are about sixty lines of writing, in such minute characters that the aid of a magnifying glass is required to ascertain their forms. Habit, and long practice have enabled me to analyze and copy the inscription on my own cylinder; that on Colonel Taylor's has not yet been examined. I find in it the name of the Kouyunjik king, with those, I think, of his father and son. Other royal names are frequently repeated, and the whole appears to be some public document or historical record.|| The identification of the frag-

* Simplicius, Aristot. de Cælo, l. ii.

† "E diverso Epigenes, apud Babylonios dccxx. annorum observationes sidærum cætilibus laterculis inscriptas, docet gravis auctor in primis, qui minimum, Berosus et Critodemus cccxc. annorum. Ex quo apparet æternum literarum usum." — *Plin. Hist. Nat.* l. vii. c. lvi. s. 57. ed. Sillig. In some editions of Pliny a thousand years is added to both these periods; but this appears to have been an error of Brottier, rectified in the last edition, as quoted.

‡ "Thou also, son of man, take thee a tile, and lay it before thee, and portray upon it the city, even Jerusalem."—Ch. iv. 1.

§ That formerly in my possession was used as a candlestick by a respectable Turcoman family living in the village, on the mound of Nebbi Yunus near the tomb of the prophet. The cylinder is hollow, and was probably closed at both ends: only one extremity is now perfect. A hole in the centre of one of the ends received the tallow candle. To such base uses are now turned the records of the Assyrians! I also found half of another cylinder of the same kind.

|| The inscription will be included in the collection brought by me from Assyria, now in the course of publication by the Trustees of the British Museum

ment (probably of a similar cylinder) published in Ker Porter's Travels, with the inscription on the stone in the Museum of the East India Company, containing decrees or annals of Nebuchadnezzar, renders it highly probable that these cylinders were generally used for such purposes.

In many public and private collections there are inscriptions on tiles, and on barrel-shaped cylinders of baked clay. On a tile formerly in the possession of Dr. Ross of Baghdad, and afterwards, I believe, in that of the late Mr. Steuart, there are many lines of writing, accompanied by the impression of seals, probably of attesting witnesses.*

The inscriptions on the Babylonian bricks are generally inclosed in a small square, and are formed with considerable care and nicety. They appear to have been impressed with a stamp, upon which the entire inscription, and not isolated letters, was cut in relief. This art, so nearly approaching to the modern invention of printing, is proved to have been known at a very remote epoch to the Egyptians† and Chinese. The characters on the Assyrian bricks were made separately. Some letters may have been impressed singly by a stamp, but from the careless and irregular way in which they are formed and grouped together, it appears more probable that they were all cut with an instrument, and by the hand.‡ The characters, however, on the cylinders, particularly on one or two fragments discovered at Nimroud, are so elaborately minute.§

* On a fragment brought by me from Nimroud, in the most minute letters, are parallel columns apparently of words and numbers, perhaps an account. On a rectangular tile, also formerly in the possession of Mr. Steuart, a small engraved cylinder of stone or metal appears to have been rolled or passed completely round the edges, probably to prevent enlargement or counterfeiting of the document.

† The Egyptian monarchs also stamped their names on bricks. The stamps used were of wood, and several are preserved in European collections. The characters are, I believe, generally *incised*, so that the impression, unlike that on the Babylonian bricks, is in relief.

‡ The stamp being used in Babylonia, and not in Assyria, may furnish an additional argument in favor of the greater antiquity of the Assyrian writing.

§ Particularly on a very beautiful fragment of baked clay now in the British Museum.

and at the same time so accurately made, that only an instrument of the most delicate construction could have produced them.

The great antiquity of carving documents on stone, is shown by the Bible. The divine commands were first given to mankind on stone tablets, and amongst all primitive nations this appears to have been considered the most appropriate and durable method of perpetuating records. The letters were evidently cut with a sharp instrument of iron, or of prepared copper. From the passage in Job,* "Oh that my words were written! that they were graven with an iron pen and *lead* in the rock for ever!" it has been conjectured that the incised letters were filled up with lead. No remains of metal were found by me in the inscriptions; but M. Botta states, that in letters in the pavement slabs of Khorsabad, traces of copper were still evident, the stone being colored by it.†

The cuneiform characters on most of the monuments of Assyria and Persia are formed with great neatness and care. Major Rawlinson states, that on the surface of the rock at Behistun could still be traced the remains of varnish, or some transparent substance, which appears to have been laid over the whole tablet to preserve it, as far as possible, from injury, by exposure to the atmosphere. No kind of letter can be better adapted to resist the ordinary process of decay than the Assyrian when well sculptured. Simple horizontal or perpendicular lines, deeply incised, will defy for ages the effects of decay. When an inscription is so much injured, that a person unaccustomed to the examination of similar monuments, would either fail to distinguish it, or would soon abandon an attempt to copy it as hopeless, it is frequently possible, by watching the shadows thrown by the sun, to transcribe the whole. Some

* Ch. xix. 23 and 24.

† Botta's letters in the *Journal Asiatique* and Flandin's memoirs in the *Revue des deux Mondes*. I discovered at Khalah Sherghat a fragment of a copper tablet with cuneiform letters.

inscriptions, visible at certain periods of the day, entirely vanish at others, and would escape even the most experienced eye.*

The foregoing remarks will, it is hoped, have given the reader some insight into the writing of the Assyrians. It only remains for me to add that the great trilingual record of Behistun, the inscription over the tomb of Darius near the ruins of Persepolis, and various shorter and less important inscriptions in other parts of Persia, have afforded a groundwork for the investigation of the Assyrian character. From the progress already made, there is every reason to hope, that within a short period we shall be able to ascertain the general contents, if not to give accurate translations, of the numerous inscriptions which have, within the last three years, been added to the written records of the ancient world. The labor of deciphering an unknown character, probably representing an extinct dialect, if not an extinct language, is however very great. Not only is an intimate acquaintance with etymology and philology absolutely required, but at the same time considerable ingenuity, a vast deal of mere mechanical investigation, and a tedious comparison of all known inscriptions in the same character. I have already alluded to the extreme laxity prevailing in the construction, and orthography, of the language of the Assyrian inscriptions, and to the number of distinct characters which appear to make up its alphabet. Letters differing widely in their forms, and evidently the most opposite in their phonetic powers, are interchangeable. The shortest name may be written in a variety of ways; every character in it may be changed, till at last the word is so altered, that a person unacquainted with the process which it has undergone, would never suspect that the two were in fact the same.

* Such are the inscriptions in the Babylonian character discovered by Major Rawlinson near Holwan, to the west of Kirmanshah, and also to a certain extent the inscription partly copied by me at Palou. I was unable to distinguish the letters in one corner of the tablet which, during my visit, was thrown into the shade by a projecting ledge. Dr. Smith, who first saw the tablet, was doubtful whether there were still any remains of the inscription upon it.

These changes will be pointed out hereafter in the name of the king who appears to have been the founder of the earliest edifice at Nimroud.

By a careful comparison of inscriptions more than once repeated, it will be found that many characters, greatly or even altogether differing in form, are only varieties or variants of the same letter. If we determine, by a process of comparison, the number of characters which have evidently the same phonetic power, and admit that many letters have, to a certain extent, a syllabic value, consonants being differently formed according to the vowel sound attached to them, the number of letters may be reduced within the compass of an alphabet.*

We derive another important aid in deciphering from the well-proved fact, that in Assyrian monumental writing it was never the custom to divide a word at the end of a line. To avoid doing so, the sculptor would carry it beyond the limits of the rest of the inscription, or would prefer finishing it on the side, or even back, of the slab. This appears also to have been frequently the case when inscriptions were carried across figures, the word not being divided, when an interruption from drapery, or other portions of the sculpture, took place. The knowledge of this fact has enabled me, by a careful comparison of the inscriptions of similar import, which are repeated on almost every slab in the earliest palace of Nimroud, to determine nearly all the words in them.† Several proper names, in the trilingual inscriptions, particularly those of kings and countries, have given us the undoubted value of many letters, and have enabled us to find corresponding geographical names

* A table, drawn up by the careful comparison of several hundred inscriptions, will be included in the work published by the Trustees of the British Museum. It shows a large number of variants and marks the division between words. M. Botta has also published a highly useful table of variants in the "Journal Asiatique" for October 1847.

† In the Persian cuneiform inscriptions each word was separated by a slanting wedge; hence one of the principal difficulties in deciphering is avoided. But such is not the case either in the Assyro-Babylonian or in the Median.







on the Assyrian monuments. We are able at the same time to prove that the name of a man* is generally, if not always, preceded by a simple wedge, and to determine the character representing "son of," as well as that meaning a country, or denoting that the following name belongs to a people or to a nation. The names of cities, above their sculptured representations in the bas-reliefs, are also always preceded by a determinative sign.†

Such are the materials for inquiry. They are considerable; quite sufficient indeed to warrant the hope of future success, when the investigation is pursued by such men as Rawlinson, Birch, or Norris, and others, in France and Germany, no less distinguished for extensive philological acquirements, than for eminent abilities, perseverance, and ingenuity.‡

I have thus placed before the reader the principal steps made towards deciphering the Assyrian inscriptions, and pointed out the amount of knowledge we possess. I will now return to the inscriptions of Nimroud, and resume the arguments afforded by them as to the comparative dates of the various buildings.

I have had frequent occasion to observe that there is scarcely a kiln-burnt brick or a stone employed in the ancient edifices of Assyria without an inscription upon it. In buildings of various epochs we find different formulæ; but in every mound where there are remains of but one building, as at Khorsabad

* And sometimes the personal pronoun.

† The character preceding the proper name, and those signifying "son of" and "king," are given elsewhere. That denoting country is  or , a city  or its variant . There is reason to believe that  precedes the name of a divinity.  is the sign of the plural.

‡ Since writing the above I have learnt from Major Rawlinson that he has succeeded in deciphering the inscription on the obelisk described in the preceding pages. It contains, according to him, the annals of the reign of the son of Ninus. He has obtained, moreover, fifteen royal names.

for instance, one formula is constantly repeated, with a few unessential variations. The inscription on the bricks of the earliest palace at Nimroud, that in the northwest corner, is as follows:—

>IIIY H* I >>V A N ((I << S >)
 N H A ((I << S >)
 N < A S ((I << S > -E)

The inscription, which is found on almost every slab in the same building, commences nearly in a similar way:—

>IIIY H I >>V A N (>III >>V H >III >+ <<
 >+ >+ I I H H I A >+ N <I <+ H I H
 >I I H H I >+ I << H I << << >III >+
 << I << >> >>V) N H A ((H >III << >III H
 << I << >> >>V) N < A S ((I << S > >>V)

On the bricks discovered in the centre palace we have the following inscription:—

I >+ <H H H A >+ >+ ((H >III >+
 << >III >+ << I << >> >)

* It has been conjectured that these two characters signify "the great house" or palace; but there appears to me to be objections to this interpretation. They are sometimes replaced by >A.

† Characters, in which perpendicular wedges are placed between two horizontal wedges, are formed, in the oldest inscriptions, by carrying one horizontal wedge across the perpendicular. I have not made this distinction in the text.

𐎶 𐎶 𐎶 → 𐎶 𐎶 𐎶 (𐎶 𐎶 𐎶)
 𐎶 𐎶 𐎶 𐎶 𐎶 𐎶 𐎶 𐎶 𐎶 𐎶)
 𐎶 𐎶 𐎶 𐎶 𐎶 (𐎶 𐎶 𐎶 𐎶 𐎶)
 𐎶 𐎶 𐎶 𐎶 𐎶 𐎶 𐎶 𐎶 𐎶 𐎶
 𐎶 𐎶 𐎶 𐎶 𐎶 𐎶

It is evident that in these inscriptions a certain formula is repeated three times,* preceded on each occasion by a different group of characters. In the inscriptions from the earliest palace, these groups are → 𐎶 𐎶 𐎶, 𐎶 𐎶 𐎶 and < 𐎶 𐎶 𐎶—in those from the centre → 𐎶 𐎶 𐎶 𐎶 𐎶 𐎶 𐎶 𐎶 𐎶 𐎶, → 𐎶 𐎶 𐎶 and 𐎶 𐎶 𐎶. It will also be observed that, in both inscriptions, the groups before the second and third repetition of the formula, are preceded either by 𐎶 𐎶 𐎶 or by 𐎶 𐎶 alone. On comparing the Persian trilingual inscriptions, it is found that in the Babylonian column, the names of the kings, as well as all proper names, are preceded by a simple perpendicular wedge (𐎶); and further, that 𐎶 𐎶 𐎶 replaces the “son of” of the Persian. We have, therefore, in the inscriptions given above, three names in direct descent, the last being the builder or founder of an edifice, and his name occurring on every stone and nearly every brick in it. It will also be perceived that in the inscription from the second palace, the position of two of the names occurring in the first are changed, and that the other no longer appears. The son in fact becomes the father, and the father the grandfather; whilst the last in the list, or the builder of the new edifice, is a name not found in the first series.

* I have placed this formula within brackets.

On a pavement slab in the upper chambers, to the south of the northwest palace,* we have a further list of names of considerable importance; for not only do four appear in genealogical series, thus confirming our first conjecture, but two new names are added.

The image shows a line of cuneiform characters arranged in four rows. The characters are stylized and represent names in a genealogical series. The first row contains several groups of characters, including a group of three vertical bars. The second and third rows contain more complex groups, some with horizontal bars and others with vertical bars. The fourth row contains a few more groups, including one with a vertical bar and a triangle.

We have thus six generations, three kings—the third, the fourth, and the sixth, having been founders of buildings at Nimroud.

There can be little doubt that the names are those of kings. In the first place, the groups following them can be shown, by referring to the trilingual inscriptions, to be royal titles; and secondly, the interpretation of the legends on the Babylonian bricks, and analogous discoveries in Egypt, prove that it was customary to impress the name of the king upon the materials used in public edifices. Besides, a name of such common and general occurrence can hardly be that of a private individual.

In the inscription on the slab opposite wall *k*, in the southwest palace,† we have a new name accompanied by royal

* See page 20 of this vol. This slab is on its way to the British Museum.

† and are interchangeable characters.

‡ The other names (and) occur after

in this inscription, but are not placed, as far as I can ascertain, in genealogical series. A further knowledge of the character is necessary before it can be determined how they are used.



§ See p. 32 of this vol.

titles, ;* and I think I can distinguish that of the father, if not that of the grandfather also, of the monarch. The inscription, however, from the injuries the slab has sustained, requires a more careful examination than I have yet been able to give it. There can be no doubt that it was brought from elsewhere, with other materials used in the construction of the building in which it was found. It did not belong to either the palace in the northwest, or in the centre of the mound; for not only is the name new, but the peculiar arrangement of the wedges in the characters, point to a different and more recent period than that of the erection of those edifices.

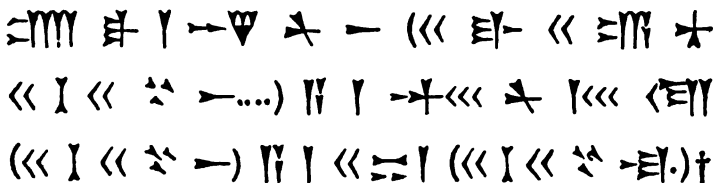
Behind the bulls and lions in the southwest palace, as well as on baked bricks from the same building, we have the following highly important genealogical series.



The first name is identical with that of the king who founded the earliest palace at Nimroud, but those of his father and grandfather do not occur elsewhere in the ruins. The name of the father is, however found on the bricks, and in the inscriptions from Kouyunjik, and that of the grandfather on

*  appears to be equivalent to . This character evidently means "King."

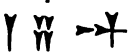
† There appears to be a name in the body of this inscription between the first and second in the genealogical series in the text, viz. , accompanied, I think, by a royal title, which certainly seems to belong to the list: it may have been that of a brother, or of one not in the line of descent, but still succeeding to the throne; if so, we should have in this inscription the names of four monarchs following one another.

the monuments of Khorsabad.* We are consequently able to fix the comparative period of both these buildings, with reference to the most recent palace at Nimroud. And this direct proof afforded by the genealogy is confirmed by the identity of style in the sculptures, and in the form of the letters used in the inscriptions from the three buildings—so much so, that long before the discovery of the ruins of Kouyunjik, and those in the southwest palace of Nimroud, I conjectured, from the

* The name of the Khorsabad king is also written $\ll \text{𐎧𐎠𐎫} \text{𐎠𐎢𐎽}$; for the name of the Kouyunjik king we have the following variation $\text{𐎧} \text{𐎠𐎢} \text{𐎠𐎢𐎽}$ 𐎧𐎠𐎢 , that is to say, that whilst the name, as given in the text, is inscribed on

the backs of the slabs, and over the head of the king in the sculptures, as well as on all the bricks I have yet discovered in the ruins opposite Mosul, it occurs in the above form at the commencement of the inscriptions on the front of the bulls (being written, as in the text, on the back). The inference, therefore, naturally is, that the name is the same, or that it may be a title or a prænomen. The well-known laxity of the Assyrian writing admits either supposition. There are other variations, but not so essential, in the orthography of the name. I am aware that Dr. Hincks (on the Inscriptions of Van, Journal of the Royal Asiatic Society) denies that the two names found on the bricks and slabs from Khorsabad are identical; believing one (that found at Nimroud, in the short inscription from the southwest palace) to be the name of a king who may have partially built the Khorsabad edifice, and the other to be that of a successor of even the last king mentioned at Nimroud. He reads the first Nishar, and identifies the others with Sennacherib, Essarhaddon, and Chînîlidan. Between the last two kings, according to the astronomical canon, there must have been a lapse of more than sixty years. If Dr. Hincks's view, therefore, be correct, we have an additional argument in favor of the antiquity of the earliest palace at Nimroud. But I may observe, that there are very strong grounds for suspecting the identity of the two names occurring on the monuments of Khorsabad. It will be remembered that on the alabaster vases discovered in the ruins of Nimroud both occur; and if the Nimroud edifices were finally buried whilst the last palace was building—as I have shown there are good reasons for suspecting—no doubt will any longer remain as to their identity. Dr. Hincks infers, from the names of the father and son occurring in the Khorsabad inscriptions, that the building could not have been completed, although founded, by the father; but that it was customary also to insert the name of the son, is shown by the existence of the name, even accompanied by a royal title, of the son of the founder of the earliest palace of Nimroud, in some of the inscriptions from that building. If the two names are not those of the same persons, we must add them to our royal list.

examination of mere fragments from them, that they belonged to the same period as Khorsabad.

We have thus, in the foregoing inscriptions, the names of ten, if not twelve, kings; the first six in genealogical series, the seventh standing by itself, and the last three again showing a direct descent, but unconnected with any of the previous. I have already mentioned the tablet in the tunnel of Negoub, which was unfortunately destroyed before I was able to obtain an accurate copy of the inscription upon it.* On examining, after my return to England, the fragment that the little light in the place permitted me to transcribe, and which before appeared to be almost unintelligible, I find a genealogical list, and I think I recognize the names of the Kouyunjik king, of the founder of Khorsabad, and of his father,† and perhaps even his grandfather. But the ends of the lines have been destroyed, and the series is consequently interrupted. The two additional names are $\Rightarrow\Upsilon$ (?) $\Rightarrow\Upsilon$ (?) $\Rightarrow\Upsilon$ (?) $\Upsilon\Upsilon$ ($\lll \Upsilon\Upsilon$) (line interrupted,) and $\Upsilon\Upsilon \Upsilon \Upsilon$ $\Rightarrow\Upsilon$ $\Rightarrow\Upsilon$ ($\lll \Upsilon\Upsilon$) $\Rightarrow\Upsilon$ ‡ The forms of the characters are those of the late Assyrian period.

Although the evidence afforded by the two additional names in this inscription is entitled to considerable weight, I will not dwell upon it. Placing only one name between each of the kings in the three distinct series given above, and supposing these kings to have succeeded one another, we have eight generations between the founder of the first edifice and

* See Vol. I. p. 84.

† It is worthy of observation that the name of the father of the builder of Khorsabad has not yet been found in any inscription from that building.

‡ The whole fragment will be given in the collection of Assyrian inscriptions, published by the Trustees of the British Museum. I may observe, that since writing the above, I have received a letter from Major Rawlinson, to whom I sent a copy of the fragment, and that he is inclined to doubt the identification of the names with those of the Khorsabad and Kouyunjik kings, and to believe that this is a distinct royal series; if so, we have still more important evidence of the antiquity of the earliest edifice of Nimroud.

the last, or in all ten. If we allow, as is usual, thirty years to a generation, we have a lapse of 300 years. The first palace could not, therefore, have been founded later than about 900 years before Christ.

But there are several circumstances which seem to prove, that a very long interval elapsed between the construction of the palaces in the north and centre of the mound, and that at the southwest corner. The latter is chiefly built, as I have had frequent occasion to remark, of slabs taken from the others; but there are, at the same time, sculptures and inscriptions in this edifice evidently coming from some ruin not yet discovered, and differing in many respects from those known to exist in any other building at Nimroud. These edifices appear, from the frequent repetition of the figures of the gods, to have been either temples, or, as there is reason to believe was the case in Egypt, royal residences combined with those of the gods. It may, therefore, reasonably be conjectured that a considerable period elapsed before a monarch pulled down the sacred buildings of kings of his own race and faith, to raise out of the materials a new habitation for himself or his divinities. A contrary supposition would be opposed to all we know of the religious feelings and prejudices of the ancients. The buildings destroyed must either have belonged to so remote a period, that not only all remembrance of those who erected them had passed away, which was not likely to have been the case in Assyria, as the written character was still preserved, or a new religion had been introduced with a new dynasty.

That a new race, with new forms of worship, had succeeded to the original inhabitants of the country; or, what is more probable, that a new dynasty had taken the place of the old, seems to be shown by the monuments themselves. There are remarkable differences between the sculptures from the earliest palace of Nimroud, and those from Khorsabad. The costumes change; the forms of the chariots, the trappings of the horses, the helmets and armor of the warriors are no longer the same. The mode of the treatment of the subjects, the nature of the

sculpture, and the forms of the characters used in the inscriptions, vary essentially. At Khorsabad, and Kouyunjik, we find no traces of the religious emblems so frequent in the sculptures of the northwest palace of Nimroud. The emblem of the great divinity, the winged figure within the circle, has never been found at Khorsabad, Kouyunjik, or in the latest palaces of Nimroud. From the frequent representations of the fire-altar in the bas-reliefs from those ruins, and on cylinders evidently of the same period, there is reason to believe that a fire-worship had succeeded to the purer forms of Sabæanism. The language, too, of the earliest inscriptions, appears to vary essentially from that used in the latest. Major Rawlinson is of opinion that, whilst the language spoken by the builders of the most ancient Assyrian monuments was far removed from the Chaldee of a known historic period, that of the inscriptions of Khorsabad approaches very closely to the Babylonian dialect; which again is nearly allied to the Chaldee of sacred literature, and of the Sadr of the Sabæans. Indeed it may be foreseen, that the reading of the early Nimroud inscriptions will be a task of no easy accomplishment, and will be best arrived at by a prior knowledge of the contents of those of Khorsabad.

All these facts lead to the belief that the palaces at Khorsabad and Kouyunjik, and in the southwest corner of the mound of Nimroud, were built by a later race or dynasty of kings. It is not indeed impossible, but on the contrary there are circumstances to lead to the conjecture, that the edifices in one part of the mound of Nimroud were already in ruins, and buried under ground, before those in another part were founded. The flooring, or foundations, of the southwest palace is *on a level* with the tops of the walls of the northwest, and of the centre palaces. It is not probable that an edifice should have been erected adjoining the ruins of a more ancient, and so much above it, that the artificial mound must have been carried up to the level of the roof of the ruined building. It would moreover appear, from a peculiar depression in the

mound, that when the slabs of the northern wall of the great hall (B, in plan 3,) were carried away for the construction of the southwest palace, excavations were made to reach them. It may be mentioned as a curious fact to corroborate this supposition, that two of the slabs* had fallen *back* from their places, not into the room, but into the place where the wall of sun-dried bricks, of which they had originally formed the casing, ought to have been; so that this wall must have been removed. On examining the ruins carefully, it appeared to me as if the builders of the most recent palace, having found a suitable position for an edifice on the artificial elevation at Nimroud, and discovering that remains were buried in it, enlarged the mound by adding to it on the south side. Having raised this new platform to the height of the ruins, covered, as they then were, with earth, they built upon it, digging, for their materials, into the old palaces. And it may be remarked, as almost conclusive evidence that the palaces of different periods were not standing at the same time, that whilst the most recent building at Nimroud had been completely destroyed by fire, *the northwest and centre palaces had not been exposed to a conflagration*, nor are there any traces of smoke, or of the action of fire, in any part of these buildings. It will be remembered that Khorsabad, Kouyunjik, and the southwestern palace of Nimroud, all edifices of the same period, owe their destruction to the same cause. It would appear, therefore, that the monuments of the latter dynasty were destroyed at a different time, and altogether in a different manner from those of the first, which must have been concealed to escape the same fate. These are important facts in our inquiry, and may be connected with the assertion of Diodorus, that on the taking of Nineveh by the Medes, under Arbaces, the city was destroyed; or with the usual historical account of the death of Sardanapalus, about 876 or 868 years before Christ.†

* Nos. 27 and 28, ch. B, plan 3.

† There is much confusion with regard to the dates of these events, which Clinton (*Fasti Hellenici*, vol. i.) has endeavored to clear up. By some the destruc-

The northwest palace, if already in ruins or buried, must have been partly uncovered, perhaps excavated for materials, in the time of the Khorsabad king; because there was in one of the chambers, as I have already mentioned,* an inscription commencing with his name, cut above the usual standard inscription. It has every appearance of having been placed there to commemorate the reopening, discovery, or reoccupation of the building. Moreover, the vases bearing the name of this king, and found in the rubbish above the chambers, must be of the same period. The ivory ornaments I conjecture to be contemporaneous with the vases, and so also most of the small objects found in the edifice. And if this fact be established, we may obtain important chronological data; for if the name in the cartouche could be satisfactorily deciphered, and identified with that of any Egyptian king, or with that of any Assyrian king whose place in history can be determined, we should be able at once to decide the period of the reign of the Khorsabad king, and of his successors.

As the name cannot yet be determined, Mr. Birch, in a memoir read before the Royal Society of Literature, has endeavored to fix the age of the ivories by "their artistic style, by philological peculiarities, and by the political relations between Egypt and Assyria."† He well observes, that the style is not purely Egyptian, although it shows very close imitation of Egyptian workmanship, and this must strike any one who examines these fragments. The solar disc and plumes surmounting the cartouche, appear to have been first used in the time of the 18th dynasty, in the reign of Thothmes III., and are found above the names of kings as late as the Persian oc-

tion of Nineveh and the revolt of the Medes are looked upon as distinct events, which have been confounded. But the city may have been twice destroyed; or rather, once merely depopulated, and its principal buildings overthrown, and then, subsequently, at a much later period, burnt to the ground; this is consistent with the change of dynasty which is presumed to have taken place on the first occasion, and the utter extinction of the Assyrian empire, which followed on the second.

* P. 16 of this volume.

† For engravings from the ivories, see my work on the Monuments of Nineveh.

cupation of Egypt. The head attire of the king bears some resemblance to that of Amenophis III. at Karnak, and the khepr, or helmet, also appears at the commencement of the 18th dynasty; the absence of peaked sandals, and the masses of locks of side hair, may possibly have been the fashion of the 22d dynasty.

As to the evidence afforded by the philological construction, and the employment of certain letters, all the symbols, except one, appear to have been in use from the earliest period in Egypt; the exceptional symbol, the u, was introduced generally in the time of the 18th dynasty. Mr. Birch concludes, that the time of the 22d dynasty would well suit the cartouche, if stress may be laid upon certain philological peculiarities.

We have next the evidence of political intercourse between the two countries, as showing at what period it is likely that by trade or otherwise, articles of Egyptian manufacture may have been carried into Assyria, or Egyptian workmen may have sought employment in the Assyrian cities. It has already been shown that from the commencement of the 18th dynasty a close intercourse had already commenced—chiefly, it would appear, by conquest; as the monuments of that period frequently allude to the subjugation of the countries on the borders of the Euphrates.* But it is about the time of the 21st dynasty of Tanite kings, that the relations between the two countries seem to have been most fully established, and that more than a common connection had sprung up between them. Mr. Birch has discovered, and pointed out, the remarkable evidence afforded by the names of male and female members of this, and the following dynasty, which are evidently of Semitic, and even of Assyrian origin. Those of many of the kings of the 22d, or Bubastite, dynasty, are the most remarkable instances. We have Sheshank, his sons Shapud and

* See Mr. Birch's paper on the statistical tablet of Karnak, and on the hieroglyphical inscriptions on the obelisk at Constantinople of the reign of Thothmes III. (Transactions of the Royal Society of Literature, new series)

Osorchon, Nimrot, the son of Osorchon II., Takilutha or Takellothis, Nimrot, the son of Takellothis II., and the names of queens, Lekamat or Rekamat,* Karmam or Kalmim, daughter of the Prince Nimroud and Tatepor. The two first, Sheshank and Shapud, and the names of the queens, Mr. Birch shows, are not referable to Egyptian roots, but follow the analogy of Assyrian names. Osorchon he identifies with the Assyrian Sargon, † Nimrot with Nimrod, and Takilutha with Tiglath; a word which enters into the composition of the name of the Assyrian monarch, Tiglath Pileser.

It is highly probable, therefore, that at this period, the reign of the 22d dynasty, very intimate relations existed between Egypt and the countries to the northeast of it. Solomon had married a daughter of an Egyptian monarch, ‡ and Jeroboam fled to the court of King Shishak. § The same alliances, therefore, may have been formed between the most powerful monarchs of the time—those of Assyria and Egypt. The two countries appear then to have been at peace, and in friendly communication; for we have no notice in the Bible of wars between the Assyrians and Egyptians at this period, nor does Naharaina appear amongst the numerous conquests of Shishak. As their battle-ground would probably have been some part of Syria, and the troops of one of the two nations would have marched through the Jewish territories, some record of the event would have been preserved by the sacred writers. The monuments of this dynasty do not contain any notice of triumphs and conquests to the east of the Euphrates. During

* Mr. Birch conjectures that this name may be derived from the Hebrew "Rikamat," an embroidered garment; "a Semitic word, which, considering the renown of the Assyrian looms, might have been conferred on an Assyrian female."

† In Isaiah (ch. xx. v. 1), Sennacherib appears to be so called; but it has been conjectured that Esarhaddon, who is called Sarchedon in the book of Tobit, is meant.

‡ About 1014 B. C.—1 Kings c. iii. v. 1.

§ 1 Kings c. xi. v. 40, and, according to some versions of the Septuagint, he married a relation (the Syncellus says a sister) of the Egyptian monarch. (Bœekh. Manetho, s. 315.)

this period of intimate alliance, the Assyrian monarchs may have adopted Egyptian names or prenomens, or may have employed Egyptian artists to record their names and titles in the sacred characters of Egypt. It is even possible that this connection may account for the appearance of Egyptian names in the lists of Assyrian kings.*

Thus the evidence afforded by the artistic style of the cartouches, and by their philological peculiarities, as well as by the principal period of political and commercial intercourse between the two people, appears to coincide, and points to the 22d dynasty, or 980 B. C., as the most probable period of the ivories. At the same time it must be observed that there is no argument against their being attributed to the 18th dynasty.

Mr. Birch reads the name upon the entire cartouche, Aubnu-ra, or Auvnu-ra,† which, if a mere Egyptian word, would mean the shining sun. He observes, "There is no especial deity of the Egyptian pantheon called Ubnu; yet, as this word is constructed in the same manner as the names of Egyptian deities, it may be that of an Assyrian deity, translated or transcribed into hieroglyphics. The name of Oannes, the Chaldæan god, half man, half fish, is the nearest approximation to it of the Assyrian names that have reached us. . . . There is another hypothesis applicable to this cartouche: that it represents the name of an Assyrian king transcribed into hieroglyphics. In order to identify it, if possible, with such a name, I have collated it carefully with the lists of names of Assyrian monarchs which have reached us, from Eusebius, the Syncellus, Moses of Chorene, and other chronographers of a later period." But he has been unable to identify it with any authentic name in those lists. "The name," Mr. Birch concludes, "is not philologically composed like the name of a king; and if it is supposed to be a prenomem, which the As-

* As for instance, Sethos and Horus.

† There are six symbols, or hieroglyphics: the reed A, the cord or boat-head U, the leg B, water N, the duckling U, the sun's disk and the determinative bar.

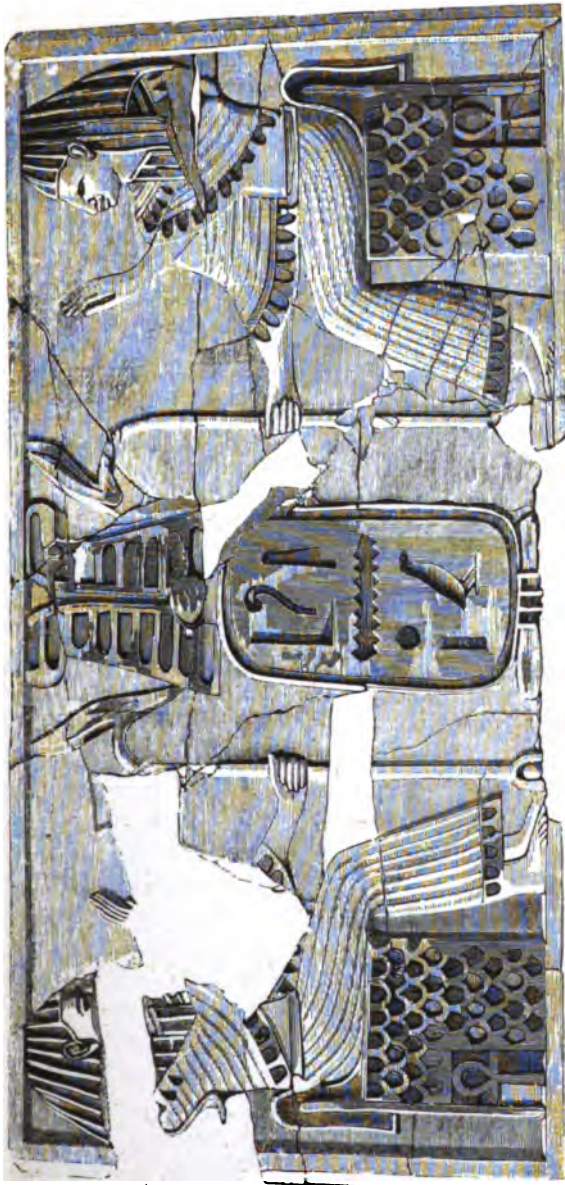

FIGURES AND CARTOUCHE WITH HIEROGLYPHICS, ON AN IVORY PANEL, (N. W. Palace, Nimroud.)

THE NEW YORK
PUBLIC LIBRARY.
ASTOR LENOX AND
TILDEN FOUNDATIONS.

syrian monarch might have assumed in imitation of his Egyptian contemporaries, there is scarcely one in the whole Egyptian series constructed in the same manner; for in these the disk of the sun is universally placed first. It is much more probable that it is a premen, than a name; in which case the fragment of the other name, in the second cartouche, might be the name of the monarch."

Unfortunately only half the panel containing this second cartouche has been preserved. Three symbols, reading NTA, or NATH, as the end of some Assyrian name, alone remain. On a fragment of ivory, not belonging to either of the cartouches, are two hieroglyphics, a duckling and the water-line, which Mr. Birch reads UN, and conjectures to be part of the name of the Assyrian deity.

In conclusion, Mr. Birch admits that the names of two Egyptian kings correspond, in a remarkable degree, with those in the Nimroud cartouches—the one being Ra-ubn, the shining sun, and the word *ubn* forming part of the other. But the following objections to their identity occur to him, viz.: "that the monarchs of this dynasty are anterior to the 18th, and were ephemeral rulers, whose reigns varied from a few months to only four years, showing either an epoch of political confusion, or a series of reigns improperly recorded. Now the Nimroud cartouche can hardly be referred to so early a period, although the Hykshos invasion is considered by some to be represented by this part of the canon. These kings cannot be connected with the shepherds. There is one period which cannot be omitted in the consideration of these Assyrian cartouches—that of the worship of the *Aten*, or sun's disk, introduced during the 18th dynasty; but there is no internal evidence that the kings of this dynasty were Assyrians." May not this very confusion indicate a foreign conquest—one of the Assyrian occupations of Egypt hinted at by Chaldee and Greek authors? And is it not a remarkable coincidence, that we have continual representations of the disk of the sun, as an object of worship, on the earliest monuments of Nineveh?

The attempt to connect the names of many Egyptian and Assyrian divinities has already been frequently made.* I will only allude to one, whose Assyrian origin is generally admitted, and whose appearance on the monuments of Egypt affords important evidence in an inquiry into the date of the Assyrian edifices. I mean the goddess Ken,† the Astarte, Astaroth, Mylitta, and Alitta of the Assyrians, Syrians, and Arabs.‡ This divinity appears to have been introduced into the Egyptian pantheon in the time of the 18th dynasty, or at the commencement of the close connection between Assyria and Egypt. On comparing a representation of the goddess in the rock sculptures of Malthaiyah, with an Egyptian bas-relief in the British Museum, it will be seen that the mode of treating the subject is nearly the same. In both we have a female standing on a lion. The Egyptian figure holds two snakes and a flower, the stalks of which are twisted into the form of a ring; the Assyrian carries a ring alone. The flower resembles that borne by the winged figures in the palace of Khorsabad, and is not found in the edifices of the first Assyrian period—where the flowers in the hands of similar figures are of a different shape.§

* For instance, the goddess Athor or Athyr. Dr. Hincks, I believe, reads the same name, as that of the presiding divinity, on the monuments of Assyria. Mr. Birch admits, in his observations on the cartouches, that the introduction of the Assyrian gods, Baal and Astarte, of Renpu or Reseph, of Ken, and Anata or Anaitis, can be traced to the 18—19 dynasty, and is coeval with the epoch of the great conquests of Egypt in central Asia.

† This is probably the Kiun of the prophet Amos. (Ch. v. ver. 26.)

‡ According to M. Fresnel (*Journal Asiatique*, iv^e série, t. v. p. 211), the goddess Athor is mentioned in the Himyaritic inscriptions.

§ This will be perceived at once by comparing the engravings in the French work on the monuments of Khorsabad, with those from the sculptures of Nimroud in my large work. As it will be shown hereafter, this lotus-shaped flower was evidently introduced into Assyria during the time of, or immediately preceding the time of, the builders of Khorsabad. There are other representations in the British Museum of this Egyptian form of the Assyrian goddess. On a fragment (Egyptian Room, No. 308) she is seen worshipped by Rameses II. On a tablet at Turin she is called Atsh, or Adesh, the name of the chief city of the Khitæ, a Mesopotamian people attacked by the Ramesida. (*Prisæe. Mon. Pl.* xxxvii.) She usu-



The Egyptian Goddess Ken.
From a tablet in the British Museum.



Assyrian Deity (? the Astarte of the Assyrians
and the Ken of the Egyptians).
From a rock tablet at Malthaiyah, near Mosul.

In the Egyptian bas-relief, of which I give a woodcut, the goddess is naked; but she is sometimes found clothed, as in Assyria. In the earliest palace of Nimroud, I discovered two representations of the same divinity, both differing entirely from those of the rock sculptures of Malthaiyah. The figure was not placed upon a lion; but the posture clearly pointed out the peculiar form of worship over which the goddess presided, the lower part of the person being obviously exposed. The Egyptian Ken appears, therefore, to be connected with the second, and not the first, mode of representation which prevailed in Assyria.*

But if the Egyptians borrowed from the Assyrians, the

ally appears in a triad with Renpu and Khen, or Chamno, also deities of Semitic extraction.

* Since writing the above I have found, in M. Lajard's great work on the worship of Venus (plate 28), the engraving of an Assyrian cylinder, on which this goddess is represented naked, and in the same posture as on the Egyptian monuments. The two, in fact, are nearly identical. From the dress of the accompanying figures (one of which carries a hatchet), I have little hesitation in ascribing this cylinder to the later Assyrian period.

emblems of Egypt were also carried to the eastward; and, it would appear, about the same time. The monuments of the second Assyrian period are characterized by more than one Egyptian peculiarity. The crux ansata, the tau or sign of life, is found on the sculptures of Khorsabad,* on the ivories from Nimroud, which, as I have shown, are of the same age, carried too by an Assyrian king, and on cylinders evidently of the later Assyrian period.† At Kouyunjik the lotus was introduced as an architectural ornament upon pavement slabs, between the bulls forming the entrances, and apparently on cornices, fragments of which were found in the rubbish at the foot of the mound. In the latest palace at Nimroud, were the crouching sphinxes with the beardless human head;‡ we have also the vases of Egyptian form, inscribed with the name of the Khorsabad king. About the same time were probably introduced the scarabæi, engraved with Assyrian emblems and characters, not unfrequently found in Assyrian ruins.§ It is probable also that the singular grotesque head carved in a yellow silex, placed by me in the British Museum, and discov-

* Botta's letters in the *Journal Asiatique* for 1843. I am aware of the ingenious arguments of M. Lajard (*Observations sur l'Origine et la Signification du Symbole appelé la Croix Ansée*, Paris, 1847), to derive the crux ansata from the Assyrian symbol of the divinity, the winged figure within the circle; but Egyptian antiquaries reject the connection altogether, not even deeming it worthy of a serious investigation. Without venturing to offer an observation on the subject, I may perhaps be allowed to suggest that the monuments already discovered, and hereafter to be discovered in Assyria, may throw new light upon many subjects connected with Egypt, and may perhaps tend to shake many received opinions.

† Their comparative date can be shown beyond a doubt, I think, by a comparison with the monuments of Khorsabad.

‡ It is doubtful whether this sphinx be male, or female, in the Assyrian monuments. I am inclined to think the latter. (See a representation of the figure, Vol. I. p. 284.) It is well known that the Egyptian sphinx is always male.

§ There are several such scarabæi in the collection of the British Museum. That the obelisk was common to the two nations, at a very early period, is proved by the one in black marble, discovered at Nimroud; and by the mention of the great obelisk said to have been erected by Semiramis at Babylon. Theophrastus (*de Lapidibus*, c. xlv.) also speaks of an obelisk of emerald, four cubits high and three broad, presented by a king of Babylon to a king of Egypt.

ered in the mound of Nebbi Yunus, near Kouyunjik, is of the same period; and an imitation of the head of the Egyptian deity, which some believe to represent death.*

Before leaving the subject of the connection between Egypt and Assyria, it may not be out of place to allude to the insertion of names, apparently of Egyptian origin, in the lists of Assyrian kings. In the dynastic list of the Syncellus, for instance, we have a Sethos; and Pliny mentions an Assyrian king called Horus.† It is difficult to say how these lists were drawn up; but it is not impossible that there may have been some traditionary evidence at least to support them, and that this appearance of Egyptian names may point to a closer connection with Egypt than history has recorded. If, in the dynasties of Egypt, whose authenticity is admitted, we find Assyrian names, why should we altogether reject Egyptian names, merely because they are Egyptian, when they occur in the dynasties of Assyria?‡

The various statements of ancient authors, as to the epoch of Ninus, remain to be considered. According to the frag-

* Wilkinson's Ancient Egyptians, plate 41, vol. iv. This head has an inscription in cuneiform letters on the crown and back; it might otherwise be mistaken for a Mexican relic. Mr. Birch suggests that, as a similar head is frequently represented on Egyptian monuments, on vases brought as tribute by an Asiatic people; and is, moreover, found on the Phœnician coins of Abusus, as that of the deity, it may be the Semitic Baal, or Typhon.

† Lib. vi. c. 30. This may be the Thurus of Cedrenus, who, according to a tradition, erected the first *stela* or pillar in Assyria. (Selden, Proleg. de Dis Syris, c. 3.)

‡ The continual confusion in sacred and profane authors between the Kushites, or Ethiopians of Asia and Africa, is worthy of remark. We have a Memnon commanding the armies of the Assyrian king at the siege of Troy, coming from Susa, and followed by the Kushites, or inhabitants of Susiana (Khuzistan). Although Virgil, falling into the common error of supposing Memnon to have been an African, calls him black (*Æneid*, l. iii.), Eustathius (in *Dionys. Perieg.* v. 248), and Triclinius, the scholiast of Pindar, say, that both he and his brother were white, although those whom they commanded were black. The birth of Memnon from Tithon and Aurora, according to the Greek mythology, evidently points to his eastern origin. Both Suidas and Pausanias (in *Phocid.*) state that he came from Susa. According to some, Tithon, his father, was the brother of Priam.

ments of Ctesias, preserved by Diodorus Siculus, there were thirty-three kings from the accession of that monarch to the fall of the empire, whose reigns occupied 1306 years, and ended 876 B. C. Diodorus himself acquiesces in this date, and Ctesias is followed by many writers, amongst them Strabo and Abydenus. Castor brings the empire down to 843 before Christ; and he reckons 1280 years from the first Ninus, to a second who succeeded Sardanapalus. According to Eusebius, 1240 years elapsed between Ninus and Sardanapalus, during which time reigned thirty-six Assyrian kings, fixing the fall of the empire at 819 B. C. The Syncellus places that event 826 years B. C., after the duration of the empire for 1460 years.* The fall of Nineveh mentioned by these authors occurred, therefore, much earlier than the destruction of the city recorded in Scripture, which must be attributed to the joint expedition of Cyaxares and Nabopolassar; undertaken, as it has been shown, about 606 B. C. The event alluded to by Ctesias and his followers may refer to the revolt of the Medes, and not to the final overthrow of the Assyrian empire. Some violent political convulsion probably took place when Arbaces enabled the Medes to assert their independence—the reigning Assyrian dynasty may have been changed, and the old Assyrian empire really brought to an end.†

Clinton, after a careful examination of the statements of the Greek writers, and after comparing them with the Scriptures, thus fixes the dates of the principal events of Assyrian history:—

* I follow Clinton's *Fasti Hellenici* in these dates (vol. i. p. 263.) In the chronology of ancient authors, we find the extraordinary discrepancy of 1535 years between the various dates assigned to Semiramis.

† Polyhistor distinctly alludes to this change of dynasty; and the names of the latter Assyrian kings, as recorded in the Bible, evidently differ materially in their construction from those of the earlier monarchs; so much, indeed, that they appear to belong to a distinct race. According to Bion and Polyhistor, the Derechades, or descendants of Semiramis, were dethroned by Beletaras, about the nineteenth in direct succession from Ninus.

(Ninus, B. C. 2182.)	Years.	B. C.
Assyrian monarchy 1306 years before the Empire	1306	1912
During the Empire, 24 Kings	526	1237
(Sardanapalus, B. C. 876.)		
After the Empire, 6 Kings	105	711
	1306	
Capture of Nineveh		606*

There are indeed sufficient grounds for the conjecture that there were two, if not more, distinct Assyrian dynasties—the first commencing with Ninus, and ending with a Sardanapalus of history; and the second, including the kings mentioned in the Scriptures, and ending with Saracus, Ninus II., or the king, under whatever name he was known, in whose reign Nineveh was finally destroyed by the combined armies of Persia and Babylon. In history we have apparently twice recorded the destruction of the Assyrian capital; and two monarchs, first Sardanapalus, and then Saracus, are declared to have burnt themselves in their palaces† rather than fall into the hands of their enemies.‡

To the tombs, in the earth covering the remains of the northwest, centre, and southeast edifices at Nimroud, I cannot at present assign any date; and, until the vases, and other objects, found in them are examined in England, I would hesitate to found an argument upon their presence. They un-

* See an elaborate Essay, in the *Memoires of the Académie des Inscriptions* (vol. vii. of the abridged ed.), by M. Freret, on *Assyrian Chronology*, in which all the authorities are carefully collected. His results agree nearly with those of Clinton.

† Saracus, according to Abydenus, in a palace called Evorita, which Major Rawlinson conjectures (Behistun Inscription deciphered, *Journal of the Royal Asiatic Society*) to be represented by the ruins of Khorsabad.

‡ According to Herodotus (lib. i. c. 176), the people of Xanthus, rather than submit to the arms of Cyrus, burnt themselves and their wives. The same thing occurred in this city when besieged by Alexander and Brutus. (*Appian. de Bello Civili.*) The anecdote is also related by Plutarch.

doubtedly prove that, at a very early period, the ruins were completely buried, and the contents of the mounds unknown.* The cartouches, ivory ornaments, and other objects, found still lower in the ruins, are sufficient to mark the period of the destruction of the building. I will only allude to the resemblance between the vases, necklaces, and ornaments from the sepulchres of Nimroud, and those discovered in Egyptian tombs. The small crouching lion in lapis lazuli, a sitting



Forms of Pottery found in the Tombs above the Ruins at Nimroud.†

figure of the same material, the beads, the forms of the vases, are all purely Egyptian.‡ Had they been placed in the hands of any antiquary, not acquainted with the circumstances of their discovery, he would not, I am convinced, have hesitated

* It is probable that when Strabo (lib. xvi.) describes the vast mounds of earth erected by Semiramis, containing subterraneous passages or communications, tanks for water and staircases of stone, he alludes to these very Assyrian ruins, a part of the contents of which might casually have been exposed by the falling in of earth, or when the winter rains formed ravines down their sides.

† This sketch was made from some Egyptian pottery in the British Museum, as I have no drawings of that found in the Nimroud tombs. The shapes, however are identical.

‡ All these small objects will be deposited in the British Museum.

to assign to them an Egyptian origin. Two or three purely Assyrian cylinders were also discovered in the tombs. Who the people were that buried their dead above the Assyrian palaces, I cannot venture at present to decide. They were not Christians, nor did they profess the Magian doctrines as taught in the time of the Sassanian kings. The inhabitants of ancient Assyria, neither during the supremacy of the Parthian Arsacidæ, of the Romans, or of the Greeks, maintained that close connection with Egypt which would have led to such general use of Egyptian symbols, or objects of Egyptian manufacture. Nor is the mode of burial Egyptian; it more nearly resembles that adopted by the early Persians. Cyrus and Darius were buried in sarcophagi, or troughs; Darius in one of Egyptian alabaster.* From the fact that tombs were found in all the most ancient ruins of Assyria, over the northwest, centre, and southeast edifices at Nimroud, at Kalah Sherghat, and Baasheikha, and not at Khorsabad, Kouyunjik, or over the southwest palace at Nimroud, it might be conjectured that they belonged to an intermediate people or race, who occupied Assyria after the building of the most ancient palaces, and before the foundation of the most recent. The close connection between Assyria and Egypt, during the time of the 18th, and four subsequent Egyptian dynasties, is naturally called to our recollection. But in the present state of our knowledge, it would be too hazardous to assign so remote an antiquity to these remains; for by doing so we must, of course, assume, that the ruins beneath are even some centuries more ancient. I will, however, attempt to show, that there is nothing inconsistent with either history or tradition in the supposition, that these buried edifices belong to a very early pe-

* The alabaster *κεύρατος*, or tub, in which Darius was buried, is mentioned by Theophrastus. The Assyrians, like the early Persians, may have buried their dead entire, and preserved their bodies in honey or wax. (Herod. lib. i. c. 140. Arian, de Bello Alex. Theoph. de Lapid. c. xv.) According to Ælian, when Xerxes opened the tomb of Belus, he found the body in a coffin, filled, nearly to the brim, with oil.

riod. I will not lay any stress upon the contents of the tombs; they may have been brought from elsewhere; and it is not impossible that they may belong to the time of the first Persian occupation, or perhaps even to the second; although the absence of coins and gems of that period is opposed to this supposition.*

It may, I think, be proved, from the facts which I have stated, that a very considerable period elapsed between the construction of the earliest and latest palaces, discovered at Nimroud. On the most moderate calculation, we may assign a date of 1100 or 1200 years before Christ, to the erection of the most ancient; but the probability is, that it is much more ancient. As I have already observed, there is nothing in history, either sacred or profane, or in the traditions handed down to us, against attributing the highest antiquity to the Assyrian empire. In the land of Shinar, in the country watered by the Tigris and Euphrates, the Scripture places the earliest habitations of the human race. Whether we look upon that statement as the result of divine inspiration, or whether we consider it as the record of a tradition, or an historical fact received by the Hebrew legislator from elsewhere, still we have the evidence that at the very earliest period, the belief was generally current, both amongst Egyptians and Jews, that the first settlements were in Assyria; and that from Chaldæa, civilization, and the arts and sciences were spread over the world.†

* It may be observed that remains of the Greek occupation of Assyria are not unfrequently found. At Nimroud a small female figure in terra cotta, evidently of that period, was discovered in the rubbish on the edge of the southeast corner of the mound.

† Berosus (or Berossos) mentions the first settlement of the human race in Chaldæa. The testimony of this author is entitled to some respect, as he was a Babylonian, living in the time of Alexander. As a priest of Belus he may be supposed to have been well acquainted with the records contained in the temple, and to have been versed in the learning for which those of his order were so distinguished. In his time the walls were probably still covered with the paintings representing the ancient deeds of the people. We know from the Scriptures how carefully public records were kept in Babylon; even those of the Assyrian empire existing after the Persian occupation. (Ezra, c. iv.) The traditions or history, preserved

Abraham and his family, above 1900 years before Christ, migrated from a land already thickly inhabited, and possessing great cities. According to Josephus, the four confederate kings, who marched in the time of the patriarch against the people of Sodom, and the neighboring cities, were under a king of Assyria, whose empire extended over all Asia.* Most of the early Greek authors, and those who have followed them, recognizing a tradition which appears to have been generally prevalent, agree in assigning to the first kings of Nineveh the remotest antiquity; and in this they are confirmed by the Armenian historians. Their united testimony even tends to identify or to confound Ninus, the first king, with Nimrod himself, or with one of the immediate descendants of the scriptural Noah.† Herodotus, who is quoted to disprove the antiquity of Ninus, merely states that the Assyrians had been *in possession of Upper Asia* for a period of 520 years, when the

by Berosus, may therefore be presumed to have been generally current in his time, amongst the Babylonians. Moses of Chorene calls him a most learned Chaldaean: "Vir Chaldaicus omnium doctrinæ peritissimus."

* Antiq. Jud. l. i. c. 9.

† Particularly that of Berosus. *Αὐτὸς Νίνου τὰς Νεβρώδαι εἰ Ἀσσυρίαι προσηγόρευον.* (Apoll. Fragments, 69, ed. Muller.) To limit the foundation of the Assyrian empire to 900 B. C., because Pul, the first Assyrian king mentioned in Scripture, can be proved to have lived about that time, as the authors of the Ancient Universal History and others have done, is, I conceive quite inconsistent, not only with all historical and traditionary evidence, but with that afforded by the Bible itself. Before the time of Pul, the Jews having no intimate dealings with Assyria, may not have been affected by events occurring in that country: this would be sufficient to account for there being no earlier mention of it, and would seem to confirm the supposition that Herodotus dates, not from the foundation of the Assyrian empire, but from its spreading over Asia. The fragments which have been handed down to us of Armenian history, through the native early Christian historians who possessed materials now lost, equally tend to fix the date of the reign of Ninus at the time usually assigned to it by the Greek authors. His cotemporary on the Armenian throne was Aram, whose son Arsus was slain by Semiramis. St. Martin, probably after a careful examination of Armenian and Greek history, placed the reign of Semiramis from 1997 to 1957, B. C. (Biog. Universel de Michaud, art. Sauchoniathon) "Primus omnium Ninus Rex Assyriorum, veterem, et quasi avitum gentibus morem novâ imperii cupiditate mutavit. Hic primus intulit bella finitimis," &c. (Just. l. i. c. 1.)

Medes first revolted and established their independence.* If we place this event about B. C. 710, and assume that Herodotus alludes to the founding of Nineveh, when he fixes the date of 520 years to the Assyrian domination in Upper Asia, then we must conclude that the Ninus who gave his name to the city did not flourish earlier than the 13th century before Christ.† But the meaning of the historian is doubtful; for he appears to reckon, not from the first establishment of a monarchy in Assyria, but from the time the Assyrians were sufficiently powerful to extend their empire over other parts of Asia. I may mention as a curious fact, first called to my attention by Major Rawlinson, but which, it must be admitted, requires further corroboration, that—whilst, in the inscriptions from the earliest edifices at Nimroud, Assyria alone is included in the dominions of the king,—in those from Khorsabad and subsequent edifices, Babylonia, Armenia, and other countries are enumerated.

But if the inscriptions of Egypt are correctly interpreted, we have distinct evidence that Nineveh was standing long before the period assigned to its foundation, on the supposed evidence of Herodotus. The name is found in the celebrated statistical tablet of Karnak. Mr. Birch, in his observations on that tablet,‡ observes: “The word Nen-i-iu has been recognized as the celebrated Nineveh on the Tigris, by Champollion. The identification of this name is not perfectly satisfactory; for as it commences the line, it is possible that it may be the termination of the name of some fort or place. As it stands, it coincides with this city, while the return of the king southwards, towards Naharaina,§ quite concurs with its

* Herod. lib. i. c. 95. Thallus, as quoted by Theophilus of Antioch, places Belus 322 years before the siege of Troy, thus appearing to agree with Herodotus.

† Or if the Median revolt took place in 876 B. C., or in 819 according to Moses of Chorene, then in the 14th century.

‡ Transactions of the Royal Society of Literature, vol. ii. p. 29, new series.

§ This name is evidently identical with the Neharajim of the Scriptures—in Syriac, Nahrim; it is a pure Semitic word, signifying the country between the two rivers, the Mesopotamia of the Greeks, the Jezirah, or island, of the Arabs.

position." It may be further mentioned, in support of the reading, that in the same tablet we have the name of Babylon, which has not been found in any other Egyptian inscription. If this name, therefore, be that of Nineveh, it occurs on a monument of the reign of Thothmes III., about 1490 years before Christ; and the arguments, founded upon the apparent testimony of Herodotus, at once fall to the ground.*

There is no reason why we should not assign to Assyria the same remote antiquity we claim for Egypt. The monuments of Egypt prove that she did not stand alone in civilization and power. At the earliest period we find her contending with enemies, already nearly, if not fully, as powerful as herself; and amongst the spoil from Asia, and the articles of tribute brought by subdued nations from the northeast, are vases as elegant in shape, stuffs as rich in texture, and chariots as well adapted to war as her own. It is not improbable that she herself was indebted to the nations of Western Asia for the introduction of arts in which they excelled, and that many things in common use were brought from the banks of the Tigris. In fact, to reject the notion of the existence of an independent kingdom in Assyria, at the very earliest period, would be almost to question whether the country were inhabited; which would be directly in opposition to the united testimony of Scripture and tradition. A doubt may be entertained as to the dynasties, and extent of the empire, but not as to its existence. That it was not peopled by mere wandering tribes, appears to be proved by the frequent mention of expeditions against Naharaina (Mesopotamia), on the earliest monuments of Egypt, and the nature of the spoil brought from the country. Fourteen hundred years before Christ, Chushan-rishathaim, a king of Mesopotamia,† subdued the Israelites. Other kings

* If there be no interpolation in the book of Genesis, we have mention of Nineveh at least 1500 years B. C.

† Judges iii. 8: and, 1450 years before Christ, Balaam, prophesying of the Kenites, describes the power of the Assyrians. (Numbers xxiv. 22.) The Arioeh

were established in the surrounding countries; all perhaps tributaries to the Assyrians. But Naharaina appears to have been the extent of the Egyptian conquests, the Egyptian kings being frequently declared to have put up the tablets of the boundaries of their empire in that country. That the Assyrian kingdom may not have been known much beyond its limits until the time of its greatest prosperity, when it had extended its rule over the greater part of Asia, is highly probable; and this would account for the silence of the Jewish writers, and for the absence of its name in most ancient Egyptian inscriptions.

With our present limited knowledge of the Assyrian character, it would be hazardous to attempt the identification of the names in the Greek and Armenian list of kings, with those in the Assyrian inscriptions; nor would I venture upon an experiment so often tried, as that of constructing a system of chronology upon these dynastic lists. I will only allude to the assertion of many writers of antiquity, that Troy was an Assyrian dependency. Memnon was at the siege of that city, with the 20,000 men, and 200 chariots, sent by the Assyrian king to the assistance of the Trojans. This king, according to Ctesias, Eusebius, and the commentators, was Teutames; whom Diodorus makes the 20th, Eusebius the 26th, and Ctesias the 25th in direct descent from Ninus. Their evidence again leads back to the earlier date for the foundation of Nineveh, to about 2100 years before Christ. According to Plato, Troy was within the dominions of the king of Assyria.* Eusebius, quoting from

king of El-Assar, mentioned in Genesis (xiv. 1), has been conjectured to be a king of Assyria; the name bearing some resemblance to Arius, the son, or Aralius, the grandson, of Ninyas. (Lenglet du Fresnoy, *Methode*, &c., vol. i. p. 258.) According to Manetho, Salathis, the first shepherd king, fortified the eastern provinces of Egypt against the Assyrians.

* De Legibus, lib. iii. He may, as it has been conjectured, have followed Ctesias, who declares that Ninus conquered, amongst other countries, Phrygia, Lydia, and the Troad. (Diodorus Siculus, lib. ii.) According to Herodotus, Agzon, the first king of Lydia, was the son of Ninus, and reigned 505 years before Candaules; and, however little worthy of credit this assertion may be, it proves at least

the works of ancient authors, mentions its dependency upon that monarch. On the authority of Cephalion, he even relates the terms in which Priam applied to his Assyrian suzerain for assistance.*

An attempt to prove that the earliest palace of Nimroud was founded by the Ninus who gave his name to the Assyrian capital, might not be altogether unsupported by plausible arguments. I hesitate at present to decide upon Major Rawlinson's identification of the name which occurs in the inscriptions, with that of the Ninus of history; although any suggestion coming from such an authority must be entitled to the greatest respect. This name, it will be remembered, is $\gg \nabla \quad \times \quad \nabla$.



When the ruins at Nimroud were first discovered, I conjectured, from the frequent recurrence of these characters both on the sculptures and on the bricks, that they must represent the name of the king. I submitted them to Major Rawlinson, and he was led to believe, from a nearly similar word corresponding in the Babylonian column of the trilingual inscriptions, to the name of Assyria in the Persian, that in the inscriptions of Nimroud the country also was meant, and that they began, "I, the king of Assyria," or with some such formula. When the genealogical series commencing the inscriptions was determined, it became evident that this was a name, and it was not unnatural to connect it with the Asshur of Genesis.† Subsequently I found, from a comparison of numerous inscriptions, that the word was written indifferently—



that, in his time, there was still a tradition of the ancient dominion of the Assyrians in Asia Minor.

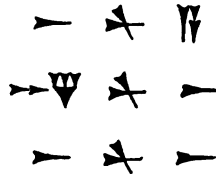

* Diod. Sic. l. ii. c. 22. Cephalion says that Priam applied to the Assyrian king in these terms: "Militari vi in regione tuâ a Græcis irruentibus appetitus sum, belloque certatum est varia fortuna. Nunc vero et filius meus Hector extinctus erat, et aliorum multa proles ac strenua. Copiarum igitur valido sub duce nobis suppetias mitte." (Euseb. ex. Interp. Armen. a Mai, p. 41.) Dares Phrygius also mentions the auxiliaries sent to Priam under Peres and Memnon.

† Chap. x. ver. 11. "Out of that land went forth Asshur, and builded Nineveh;" although the approved reading is "the Assyrian," as given in the margin.



the first and last of the three letters being resolvable into the same letter. The power of  is from independent sources conjectured to be that of an *n*, and  appears to have nearly the same phonetic power.†

The ruins themselves furnish additional evidence in support of assigning this building to the Ninus to whom tradition, at least, attributes the foundation of the Assyrian capital, and from whom the city took its name. It may be mentioned, in the first place, that the northwest edifice at Nimroud, built by   , is the most ancient hitherto discovered in

* This character is sometimes replaced by . As to the use of all these characters indifferently in this word, there cannot be a doubt. Dr. Hincks is convinced that  is either the name, or an abbreviation of the name of Athur, the country of Assyria. It is possible that Nineveh, or Athur, may be indiscriminately used in speaking of the country. Dr. Hincks appears to admit that  also stands for the city of which the historical name is Nineveh.

† Dr. Hincks has conjectured that when a letter for a consonant and a vowel sound combined is used, the letter expressing the pure consonant may also be added: this might account for the presence of three characters having the power of *n* in this word. The substitution of one character for another, as in the name given in the text, is one of the most difficult questions in the investigation of the Assyrian writing. That the letters, thus frequently found interchanging, are not always pure variants, that is, having the same phonetic value, may be shown from the example in the text,  having, there can be little doubt, the value of *a*. Letters, partly syllabic, *i. e.* having a vowel sound united with a consonant, appear to be interchangeable with pure consonants, or to be replaced by two distinct signs; but hitherto no rule to regulate any such interchanges has been discovered. They are so frequent, and numerous, that an entire inscription might almost be written in two distinct ways.

Assyria; and as all the great ruins on the site of Nineveh have now been partially explored, it may be presumed that no earlier building of this nature exists. 2dly, According to Castor, the last Assyrian king, or one of the last, of the second dynasty, perhaps the Saracus of Abydenus, was called Ninus II.* It will be remembered, that the names of the builders of the most ancient and recent edifices discovered in Assyria, are identical; and from the appearance of the southwestern building of Nimroud, there is every reason to believe that it was destroyed before completed. It may, consequently, be conjectured to have been the last of the Assyrian palaces. 3dly, Diodorus Siculus states, that in the palace of Ninus or Semiramis, at Babylon, were represented various hunting scenes, in which the queen was seen throwing a javelin at a panther, and Ninus as transfixing a lion with a lance. It is remarkable that whilst at Khorsabad and Kouyunjik such representations have not been discovered, they abound in the earliest palace at Nimroud; not only forming separate bas-reliefs, but being constantly introduced into the embroideries on the robes of the principal figures. 4thly, Ctesias, and several writers, speak of the Bactrian, and Indian expedition of Ninus and Semiramis. The obelisk discovered at Nimroud belongs to the period of the earliest palace, having, it appears, been erected by the son of the founder of that building; upon it are represented the Bactrian camel, the elephant, and the rhinoceros, all animals from India and central Asia, brought as tribute by a conquered people to the king.

Even if his father and grandfather were called in the inscriptions "kings of Nineveh," Ninus himself may still have founded and given his name to the city.† Eusebius, after

* This second Ninus is also mentioned in the *Excerpta Chronologica* Euseb. apud Scal. See authorities collected in notes to p. 265, Appendix, vol. i. of Clinton's *Fasti Hellenici*.

† Dr. Hincks, as it has been mentioned, reads the title of these early kings, "King of Assyria."

Abydenus, names six kings as the predecessors of this Ninus;* although by giving the name of Nineveh to the capital, he evidently assigns its foundation to him. This king may have been the first to build monuments, such as those recently discovered; or, he may have first used inscriptions and sculptures for monumental records; or, as Moses of Chorene states, Ninus may have displaced a more ancient dynasty, and, jealous of its glory, and wishing to appear to posterity as the founder of the race, and the origin of its arts and civilization, may have destroyed all the monuments of his predecessors.† This statement of the Armenian historian, from the advanced state of art shown in the most ancient edifices of Assyria, is not altogether unworthy of credit.

In conclusion, it may appear from the preceding remarks—

1st. That there are buildings in Assyria which so far differ in their sculptures, in their mythological and sacred symbols, and in the character and language of their inscriptions, as to lead to the inference that there were at least two distinct periods of Assyrian history. We may moreover conclude, that either the people inhabiting the country at those distinct periods were of different races, or of different branches of the same race; or that by intermixture with foreigners, perhaps Egyptians, great changes had taken place in their language, religion, and customs, between the building of the first palace of Nimroud, and that of the edifices at Khorsabad and Kouyunjik.

2d. That the names of the kings on the monuments, show

* They are Belus, Babilus, Anebus, Arbelus, Chaalus, and Arbelus. I believe Major Rawlinson is satisfied with the reading of Arbel and Aneb, for the father and grandfather of the king in the inscriptions.

† Moses Chorenensis, lib. i. c. 13. "Item et alias ejus rei rationes affert, utique Ninum superbiâ inflatum, suæque gloriæ cupidissimum, cum se unum summæ potestatis et fortitudinis ac bonitatis fontem atque originem haberi vellet, complures libros et historias antiquas rerum ubicunque egregiè gestarum jussisse concremari; et de se tantum suisque temporibus conscribi." The same is recorded of Nabonassar when he ascended the throne at Babylon.

a lapse even of some centuries, between the foundation of the most ancient and most recent of these edifices.

3d. That from the symbols introduced into the sculptures of the second Assyrian period, and from the Egyptian character of the small objects found in the earth, above the ruins of the buildings of the *oldest* period, there was a close connection with Egypt, either by conquest or friendly intercourse, between the time of the erection of the earliest and latest palaces; and that the monuments of Egypt, the names of kings in certain Egyptian dynasties, the ivories from Nimroud, the introduction of several Assyrian divinities into the Egyptian Pantheon, and other evidence, point to the 14th century as the probable time of the commencement, and the 9th as the period of the termination, of that intercourse.*

4th. That the earlier palaces of Nimroud were already in ruins, and buried before the foundation of the later; and that it is probable they may have been thus destroyed about the time of the 14th Egyptian dynasty.

5th. That the existence of two distinct dynasties in Assyria, and the foundation, about two thousand years before Christ, of an Assyrian monarchy, may be inferred from the testimony of the most ancient authors; and is in accordance with the evidence of Scripture, and of Egyptian monuments.

I cannot pretend to draw any positive conclusions from the data that I have attempted to bring together. It has been my object to place before the reader the facts which have been afforded by the examination of the ruins—facts, which, it must be admitted, will go far towards enabling us ultimately to form some opinion as to the comparative, if not the positive date of these newly discovered monuments. I trust that I have at least succeeded in showing, that there are grounds for admitting the possibility of the very early origin of some of these edifices; and that there is nothing in the discoveries hitherto

* I do not, of course, include the Assyrian conquests of Egypt, by kings of the later dynasty, which are proved by positive historical evidence, and the effects of which are well known and traceable.

made inconsistent with the early date which the dynastic lists, and the statements of ancient authors, would assign to the foundation of Nineveh. The subject is new, and has not yet been illustrated by the remains of the people themselves. The vast ruins of Egypt—its written and sculptured records—have enabled the antiquarian to enlarge, and rectify, the notices preserved to us through the Greeks and Romans; but hitherto Assyria has furnished no such materials. Their very absence has compelled us to neglect a branch of inquiry, replete with interest as connected with Biblical study, and with the history of the human race. Further researches will probably lead to the discovery of additional monuments and inscriptions, adding to the great mass of materials which in the last three years has been placed in our possession. It would scarcely be reasonable or consistent, after what has already been done, to discard all evidence of the antiquity of the Assyrian empire, because there are discrepancies in the statements of such authors as Ctesias, Eusebius, and the Syncellus; and at the same time to found arguments against that antiquity upon an isolated and doubtful passage in Herodotus, or upon the absence of the mention of an early Assyrian king in the Scriptures.

CHAPTER II.

It has been assumed in the previous chapter that the language of the Assyrian inscriptions is a Semitic, or Syro-Arabian, dialect; but the question of what race the Assyrians were, may still be considered by some as open to doubt. It may be questioned, perhaps, whether we have sufficient knowledge of the inscriptions to decide, with certainty, the language of their contents. There are, however, as it has been shown, good grounds for believing that it is closely allied to the Chaldee; or, to use a term which has become familiar, that it is a branch of the Semitic. Such, it is generally admitted, is the language of the Babylonian column of the Persian trilingual inscriptions; which, it can be shown, contains the same formulæ as the inscriptions of Assyria. For instance, the personal pronoun as used before the proper name of the king at Persepolis, is found precisely in the same position at Nimroud.* We are aware, moreover, that the names of the Assyrian gods, as Baal, or Belus (the supreme deity amongst all the Semitic races), Nisroch, and Mylitta (known by a nearly similar name to the Arabians),† of members of the family of the king, such as Adrameleck (son of Sennacherib), and of many of the princi-

* Thus : "I —" (the name of the king).

If, as Dr. Hincks conceives, the language of the Van inscriptions is an Indo-European dialect, then the Assyro-Babylonian form of arrow-headed character would not be limited to any particular branch of languages—such as the Semitic.

† Viz. Alitta, Herod. lib. i. c. 131.

pal officers of state mentioned in Scripture, such as Rab-saris, the chief of the eunuchs, and Rab-shakeh, the chief of the cup-bearers, were purely Semitic.* The language spoken by Abraham when he left Mesopotamia closely resembled the Hebrew; and his own name was Semitic.† Moreover, a dialect of the same tongue is still spoken by the Chaldæans of Kurdistan; who, there is good reason to suppose, are the descendants of the ancient Assyrians.‡

* It is, however, possible that these may be mere Hebrew translations of Assyrian titles. An argument has been founded on the 26th verse of the 18th chapter of 2d Kings. Eliakim says to the officers of the Assyrian king,—“Speak, I pray thee, to thy servants in the Syrian language; for we understand it.” From this passage it has been inferred that the language of the Assyrians was similar to that which prevailed in Syria, and consequently a Semitic dialect.

† The name of Mesopotamia on the Egyptian monuments is *Naharaina*, i. e. the country between the two rivers. This is not only a pure Semitic word, but has a Semitic plural form. We may infer, therefore, that the people inhabiting that district, at least, were of Semitic origin. The Hebrew name of Mesopotamia was *Aram Naharaim*.

‡ The question of the origin of the Chaldæans, the Casdim of Scripture, has been the subject of much discussion of late years. I confess that after carefully examining the arguments in favor of their Scythic and Indo-European descent, I see no reason to doubt the old opinion, that they were a Semitic or Syro-Arabian people. The German philologists were the first to question their Semitic origin. Michaëlis made them Scythians; Schloezer, Slavonians. According to Dicaearchus, a disciple of Aristotle, and a philosopher of great reputation, they were first called Cephenees from Cepheus, and afterwards Chaldæans from Chaldæus, an Assyrian king, fourteenth in succession from Ninus; this Chaldæus built Babylon near the Euphrates, and placed the Chaldæans in it. (Stephanus, *Dict. Hist. Geog.*) This appears to confirm the passage in Isaiah, which has chiefly given rise to the question as to the origin of the Chaldees. “Behold the land of the Chaldæans; *this people was not, till the Assyrian founded it for them that dwell in the wilderness: they set up the towers thereof, they raised up the palaces thereof.*” (Ch. xxiii. ver. 13.) The use of the term Chaldæan, like that of Assyrian, was very vague. It appears to have been applied at different periods to the entire country watered by the rivers Tigris and Euphrates, south of the mountainous regions of Armenia, to only a part of it, to a race, and ultimately to a class of the priesthood. That the Chaldees were at a very early period settled in cities, we learn from Genesis (ch. xi. ver. 31), for Abraham came from Ur of the Chaldees; but the position of Ur, whether to the north or south of Nineveh, whether Edessa (the modern Orfah) or Orchoe, or any other city whose geographical position can be conjectured, is still a disputed question, which is not likely to be soon, if ever, settled. It is right to observe

There is something, at the same time, if I may so express myself, peculiarly Semitic in the genius and taste of the Assyrians, as displayed by their monuments. This is undoubtedly a mere conjecture; but the peculiar characteristics of the three great races which have, at different periods, held dominion over the East, cannot fail to strike every reflecting traveller. The distinctions between them are so marked, and are so fully illustrated even to this day, that they appear to be more than accidental—to be consequent upon certain laws, and to be traceable to certain physical causes. In the first place, there is the Shemite, whether Hebrew, Arab, or Syrian, with his brilliant imagination, his ready conception, and his repugnance to any restraint, that may affect the liberty of his person or of his intellect. He conceives naturally beautiful forms, whether they be embodied in his words or in his works; his poetry is distinguished by them, and they are shown even in the shape of his domestic utensils. This race possesses, in the highest degree, what we call imagination. The poor and ignorant Arab, whether of the desert or town, moulds with clay the jars for his daily wants, in a form which may be traced in the most elegant vases of Greece or Rome; and, what is no less remarkable, identical with that represented on monuments, raised by his ancestors, 3000 years before. If he speaks, he shows a ready eloquence; his words are glowing and apposite; his descriptions true, yet brilliant; his similes just, yet most fanciful. These high qualities seem to be innate in him; he takes no pains to cultivate or to improve them: he knows nothing of reducing them to any rule, or measuring them by any standard. As it is with him, so it has been from time unknown with those who went before him: there has been little change—no progress.

Look, on the other hand, at the so-called Indo-European

however, that the name may be a gloss of a later version of Genesis, a substitution, after the captivity, for the name of some obsolete city. The passage in Judith (chap. v. ver. 6 and 7), in which the Jews are spoken of as descendants of the Chaldeans, is remarkable.

racés—at the Greek and Roman. They will adopt from others the most beautiful forms: it is doubtful whether they have invented any of themselves. But they seek the cause of that beauty; they reduce it to rules by analysis and reasoning; they add or take away—improve that which they have borrowed, or so change it in the process to which it is subjected, that it is no longer recognized as the same thing. That which appeared to be natural to the one, would seem to be the result of profound thought and inquiry in the other. Let the untaught man of this race model a vase, or address his fellows, he produces the rudest and most barbarous forms; or, whilst speaking roughly and without ease, makes use of the grossest images.

We have next the Mongolian, whether Scyth, Turk, or Tartar—without imagination, or reasoning powers—intrepid in danger, steady in purpose, overcoming all opposition, despising his fellows, a great conqueror. Such has been his character as long as history has recorded his name: he appears to have been made to command and to oppress. We find him in the infancy of the human race, as well as at later periods, descending from his far distant mountains, emerging from the great deserts in central Asia, and overrunning the most wealthy, the most mighty, or the most civilized of nations. He exercises power as his peculiar privilege and right. The solitary Turkish governor rules over a whole province, whose inhabitants, whilst they hate him as an intruder and a barbarian, tremble at his nod. It is innate in his children—the boy of seven has all the dignity and self-confidence in rule, which characterizes the man. The Mongolian must give way before the civilization of Europe, with its inventions and resources; but who can tell whether the time may not come when he may again tread upon the other races, as he has done, at intervals, from the remotest ages? But observe the absence of all those intellectual qualities which have marked the Shemite and the Indo-European. If the Mongolian nations were to be swept from the face of the earth, they would leave scarcely a monu-

ment to record their former existence: they have had no literature, no laws, no art to which their name has attached. If they have raised edifices, they have servilely followed those who went before them, or those whom they conquered. They have depopulated, not peopled. Whether it be the Scythic invasion recorded by Herodotus, or the march of Timourleng, we have the same traces of blood, the same desert left behind; but no great monument, no great work.

These may be but theories; yet the evidence afforded to this day, by the comparative state of the three races, is scarcely to be rejected. In no part of the world is the contrast, between the peculiar qualities of each, more strikingly illustrated than in the East, where the three are brought into immediate contact; forming, indeed mixed up together, yet still separate in blood, the population of the land. The facts are too palpable to escape the most casual observer; they are daily brought to the notice of those who dwell amongst the people; and whilst the Arab, the Greek, and the Turk, are to be at once recognized by their features, they are no less distinctly marked by their characters and dealings.*

But, to return from this digression, let us inquire whether

* Dr. Pritchard, in his valuable and learned "Researches into the Physical History of Mankind," has pointed out the peculiar characteristics of one of these great branches of the human race. "The Syro-Arabian nations," he observes, "are amongst the races of men who display the most perfect physical organization. A well-known modern writer, who has had extensive opportunities of research into the anatomical and other corporeal characters of various nations, has maintained that the bodily fabric belonging to the Syro-Arabian tribes, manifests even a more perfect development in the organic structure, subservient to the mental faculties, than that which is found in other branches of the human family. It is certain that the intellectual powers of the Syro-Arabian people have, in all ages, equalled the highest standard of the human faculties." (Vol. iv. p. 548.) And again: "It is remarkable that the three great systems of theism which have divided the civilized world, came forth from nations of Shemite origin, among whom arose the priests or prophets of all those nations, who hold the unity of God." (Vol. iv. p. 549.) If this be true of the Syro-Arabian or Shemite races, we may, without inconsistency, seek for similar characteristics in the other branches of the human family; and I believe that a careful examination of the subject will show, that the history and condition of the three great races, justify the remarks in the text.

the site of Nineveh is satisfactorily identified. That it was built on the eastern bank of the Tigris, there can be no doubt. Although Ctesias, and some who follow him, place it on the Euphrates, the united testimony of Scripture, of ancient geographers, and of tradition, most fully proves that that author, or an inaccurate transcriber or commentator of his text, has fallen into an error.* Strabo says that the city stood between the Tigris and the Lycus, or Great Zab, near the junction of these rivers; and Ptolemy places it on the Lycus. This evidence alone is sufficient to fix its true position, and to identify the ruins of Nimroud.

The tradition, placing the tomb of the prophet Jonah on the left bank of the river opposite Mosul, has led to the identification of the space comprised within the quadrangular mass of mounds, containing Kouyunjik and Nebbi Yunus, with the site of ancient Nineveh. These ruins, however, taken by themselves, occupy much too small a space to be those of a city, even larger, according to Strabo, than Babylon.† Its dimensions, as given by Diodorus Siculus, were 150 stadia on the two longest sides of the quadrangle, and 90 on the opposite, the square being 480 stadia, or about 60½ miles. In the book of Jonah, it is called "an exceeding great city of three days' journey;"§ the number of inhabitants, who did not know their right hand from their left, being six score thousand. I will not stop to inquire to what class of persons this number applied; whether to children, to those ignorant of right and wrong, or to the whole population.|| It is evident that the city was one of very considerable extent, and could not have been comprised in the space occupied by the ruins opposite Mosul,

* Herodotus, l. i. c. 193, and l. ii. c. 150; Pliny, lib. xvi. c. 13; Strabo, l. xvi.; Ammianus Marcell. l. xxiii. c. 20.

† Strabo, lib. xvi

‡ Or, according to some computations, 74 miles.

§ Chap. iii. ver. 3.

|| The numbers of Jonah have frequently been referred to children, who are computed to form one fifth of the population; thus giving six hundred thousand inhabitants for the city.

scarcely five miles in circumference. The dimensions of an Eastern city do not bear the same proportion to its population as those of an European city. A place as extensive as London, or Paris, might not contain one-third of the number of inhabitants of either. The custom, prevalent from the earliest period in the East, of secluding women in apartments removed from those of the men,* renders a separate house for each family almost indispensable. It was probably as rare, in the time of the Assyrian monarchy, to find more than one family residing under one roof, unless composed of persons very intimately related, such as father and son, as it is at present in a Turkish city. Moreover, gardens and arable land were inclosed by the city walls. According to Diodorus and Quintus Curtius, there was space enough within the precincts of Babylon to cultivate corn for the sustenance of the whole population, in case of siege, besides gardens and orchards.† From the expression of Jonah, that there was much cattle within the walls,‡ it may be inferred that there was also pasture for them. Many cities of the East, such as Damascus and Isphahan, are thus built; the amount of their population being greatly disproportionate to the site they occupy, if computed according to the rules applied to European cities. It is most probable that Nineveh and Babylon resembled them in this respect.

The ruins hitherto examined have shown, that there are remains of buildings of various epochs, on the banks of the

* We learn from the book of Esther that such was the custom amongst the early Persians, although the intercourse between women and men was much less circumscribed than after the spread of Mohammedanism. Ladies were even admitted to public banquets, and received strangers in their own apartments, whilst they resided habitually in a kind of harem, separate from the dwellings of the men.

† Diod. Sic. lib. ii. c. 9. Quintus Curtius, v. cap. 1; "Ac ne totam quidem urbem tectis occupaverunt; per xc. stadia habitatur; nec omnia continua sunt: credo quia tutius visum est, plurimis locis spargi; cetera serunt colantque, ut, si externa vis ingruat, obsessis alimenta, ex ipsius urbis, solo subministrantur."

‡ Chap. iv. ver, 11.

Tigris, near its junction with the Zab ; and that many years, or even centuries, must have elapsed between the construction of the earliest and the latest. That the ruins at Nimroud were within the precincts of Nineveh, if they do not alone mark its site, appears to be proved by Strabo, and by Ptolemy's statement that the city was on the Lycus, corroborated by the tradition preserved by the earliest Arab geographers. Yakut, and others mention the ruins of Athur, near Selamiyah, which gave the name of Assyria to the province ; and Ibn Said expressly states, that they were those of the city of the Assyrian kings who destroyed Jerusalem.* They are still called, as it has been shown, both Athur and Nimroud. The evidence afforded by the examination of all the known ruins of Assyria, further identifies Nimroud with Nineveh. It would appear from existing monuments,† that the city was originally founded on the site now occupied by these mounds. From its immediate vicinity to the place of junction of two large rivers, the Tigris and the Zab, no better position could have been chosen. It is probable that the great edifice, in the northwest corner of the principal mound, was the temple or palace, or the two combined ; the smaller houses were scattered around it, over the face of the country. To the palace was attached a park, or paradise as it was called, in which was preserved game of various kinds for the diversion of the king. This inclosure,

* Yakut, in his geographical work called the *Moejem el Buldan*, says, under the head of "Athur," "Mosul, before it received its present name, was called Athur, or sometimes Akur, with a *kaf*. It is said that this was anciently the name of el Jezireh (Mesopotamia), the province being so called from a city, of which the ruins are now to be seen near the gate of Selamiyah, a small town, about eight *farsakhs* east of Mosul ; God, however, knows the truth." The same notice of the ruined city of Athur, or Akur, occurs under the head of "Selamiyah." Abulfeda says, "To the south of Mosul, the lesser (!) Zab flows into the Tigris, near the ruined city of Athur." In Reinaud's edition (vol. i. p. 289, note 11,) there is the following extract from Ibn Said :—"The city of Athur, which is in ruins, is mentioned in the Taurat (Old Testament). There dwelt the Assyrian kings who destroyed Jerusalem." I am indebted for these notices to Major Rawlinson.

† See the previous chapter as to the identification of the names and genealogies of kings.

formed by walls and towers, may perhaps still be traced in the line of low mounds branching out from the principal ruin. Future monarchs added to the first building, and the centre palace arose by its side. As the population increased with the duration and prosperity of the empire, and by the forced immigration of conquered nations, the dimensions of the city increased also. A king founding a new dynasty, or anxious to perpetuate his fame by the erection of a new building, may have chosen a distant site. The city, gradually spreading, may at length have embraced such additional palaces. This appears to have been the case with Nineveh. Nimroud represents the original site of the city. To the first palace the son of its founder added a second, of which we have the ruins in the centre of the mound. He also built the edifice now covered by the great mound of Baasheikha, as the inscriptions on the bricks from that place prove. He founded, at the same time, a new city at Kalah Sherghat. A subsequent monarch again added to the palaces at Nimroud, and recorded the event on the pavement slabs, in the upper chambers of the western face of the mound. At a much later period, when the older palaces were already in ruins, edifices were erected on the sites now marked by the mounds of Khorsabad, and Karamles. The son of their founder built the great palace at Kouyunjik, which must have exceeded those of his predecessors in extent and magnificence. His son was engaged in raising one more edifice at Nimroud; the previous palaces, as it has been shown, having been long before deserted or destroyed, when some great event, perhaps the fall of the empire and destruction of the capital, prevented its completion.

The city had now attained the dimensions assigned to it by the book of Jonah, and by Diodorus Siculus. If we take the four great mounds of Nimroud, Kouyunjik, Khorsabad, and Karamles, as the corners of a square, it will be found that its four sides correspond pretty accurately with the 480 stadia or 60 miles of the geographer, which make the three days'

journey of the prophet.* Within this space there are many large mounds, including the principal ruins in Assyria, such as Karakush, Baasheikha, Baazani, Hussein, Tel-Yara, &c. &c. ; and the face of the country is strewn with the remains of pottery, bricks, and other fragments.

The space between the great public edifices was probably occupied by private houses, standing in the midst of gardens, and built at distances from one another ; or forming streets which inclosed gardens of considerable extent, and even arable land. The absence of the remains of such buildings may easily be accounted for. They were constructed almost entirely of sun-dried bricks, and, like the houses now built in the country, soon disappeared altogether when once abandoned, and allowed to fall into decay. The largest palaces would probably have remained undiscovered, had there not been the slabs of alabaster to show the walls. There is, however, sufficient to indicate, that buildings were once spread over the space above described ; for, besides the vast number of small mounds every where visible, scarcely a husbandman drives his plough over the soil, without exposing the vestiges of former habitations. Each quarter of the city may have had its distinct name ; hence the palace of Evorita, where Saracus destroyed himself, and the Mespila and Larissa of Xenophon, applied respectively to the ruins at Kouyunjik and Nimroud.†

* From the northern extremity of Kouyunjik to Nimroud, is about eighteen miles ; the distance from Nimroud to Karamles, about twelve ; the opposite sides of the square the same : these measurements correspond accurately with the elongated quadrangle of Diodorus. Twenty miles is the day's journey of the East, and we have consequently the three days' journey of Jonah for the circumference of the city. The agreement of these measurements is remarkable. Within this space was fought the great battle between Heraclius and Rhazates (A. D. 627). "The city, and even the ruins of the city, had long since disappeared : the vacant space afforded a spacious field for the operations of the two armies." (Gibbon, *Decline and Fall*, ch. xlv.)

† I have already shown that the account given by Xenophon of Larissa, as well as the distance between it and Mespila, agree in all respects with the ruins of Nimroud, and their distance from Kouyunjik. (Vol. I. p. 27.) The circuit of the walls

Existing ruins thus show, that Nineveh acquired its greatest extent in the time of the kings of the second dynasty; that is to say, of the kings mentioned in Scripture. It was then that Jonah visited it, and that reports of its size and magnificence were carried to the west, and gave rise to the traditions from which the Greek authors mainly derived the information handed down to us.

I know of no other way, than that suggested, to identify all the ruins described in the previous pages with Nineveh; unless, indeed, we suppose that there was more than one city of the same name; and that, like Babylon, it was rebuilt on a new site, after having been once destroyed.* In this case Nimroud and Kouyunjik may represent cities of different periods, but of the same name, for, as I have shown, the palace of Kouyunjik must have been built long after the foundation of the Nineveh of well-authenticated history. The position of Khorsabad, its distance from the river, and its size, preclude the idea that it marks alone the site of a large city. As the last palace at Nimroud must have been founded whilst those at Kouyunjik and Khorsabad were standing, it is most probable that the city at that time embraced the remains of the old town, although the earlier buildings may have been destroyed.

Having thus pointed out the evidence as to the site and extent of Nineveh, it may not be uninteresting to inquire how it was built, and what knowledge the Assyrians possessed of the science of architecture.

The architecture of a people must naturally depend upon the materials afforded by the country, and upon the objects of their buildings. The descriptions, already casually given in the course of this work of the ruined edifices of ancient Assyria, are sufficient to show that they differ, in many respects,

of Larissa, two parasangs, also nearly coincides with the extent of the quadrangle at Nimroud.

* The attempt to identify Larissa and Nimroud with Resen, will, I presume, be now renounced.

from those of any other nation with which we are acquainted. Had the Assyrians, so fertile in invention, so skilful in the arts, and so ambitious of great works, dwelt in a country as rich in stone and costly granites and marbles as Egypt or India, it can scarcely be doubted that they would have equalled, if not excelled, the inhabitants of those countries in the magnitude of their pyramids, and in the magnificence and symmetry of their rock temples and palaces. But their principal settlements were in the alluvial plains watered by the Tigris and Euphrates. On the banks of those great rivers, which spread fertility through the land, and afford the means of easy and expeditious intercourse between distant provinces, they founded their first cities. On all sides they had vast plains, unbroken by a single eminence until they approached the foot of the Armenian hills.

The earliest habitations, constructed when little progress had been made in the art of building, were probably but one story in height. In this respect the dwelling of the ruler scarcely differed from the meanest hut. It soon became necessary, however, that the temples of the gods, and the palaces of the kings, depositories at the same time of the national records, should be rendered more conspicuous than the humble edifices by which they were surrounded. The means of defence also required that the castle, the place of refuge for the inhabitants in times of danger, or the permanent residence of the garrison, should be raised above the city, and should be built so as to afford the best means of resistance to an enemy. As there were no natural eminences in the country, the inhabitants were compelled to construct artificial mounds. Hence the origin of those vast, solid structures, which have defied the hand of time; and, with their grass-covered summits and furrowed sides, rise like natural hills in the Assyrian plains.*

* The custom of erecting an artificial platform, and building an edifice on the summit, existed amongst the Mexicans, although they inhabited a hilly country.

Let us picture to ourselves the migration of one of the primitive families of the human race, seeking for some spot favorable to a permanent settlement, where water abounded, and where the land, already productive without cultivation, promised an ample return to the labor of the husbandman. They may have followed him who went out of the land of Shinar, to found new habitations in the north;* or they may have descended from the mountains of Armenia; whence came, according to the Chaldæan historian, the builders of the cities of Assyria.† It was not until they reached the banks of the great rivers, if they came from the high lands, or only whilst they followed their courses, if they journeyed from the south, that they could find a supply of water adequate to the permanent wants of a large community. The plain, bounded to the west and south by the Tigris and Zab, from its fertility, and from the ready means of irrigation afforded by two noble streams, may have been first chosen as a resting place; and there were laid the foundations of a city, destined to be the capital of the eastern world.

The materials for building were at hand, and in their preparation required neither much labor nor ingenuity. The soil, an alluvial deposit, was rich and tenacious. The builders moistened it with water, and, adding a little chopped straw that it might be more firmly bound together, they formed it into squares, which, when dried by the heat of the sun, served them as bricks. In that climate the process required but two or three days. Such were the earliest building materials; and they are used to this day almost exclusively in the same country. This mode of brick-making is described by Sanchoniathon;‡

* Genesis x. 11.

† Xithurns and his followers Berosus, apud Euseb. The similarity between the history of this Chaldæan hero and that of the Noah of Scripture is very singular.

‡ According to Sanchoniathon (Cory's Fragments), the people of Tyre invented the art of brick-making, and of building huts. "Hypouranius," he says, "invented in Tyre the making of huts of reeds and rushes, and the papyri. After the generation of Hypouranius were Agreus and Halieus, inventors of the arts of hunt-

and we have an allusion to it in Exodus;* for the Egyptians, to harass their Jewish captives, withheld the straw without which their bricks could not preserve their form and consistency.

Huts for the people were speedily raised; the branches and boughs of trees from the banks of the river serving for a roof.

They now sought to build a place of refuge in case of attack, or a habitation for their leader, or a temple to their gods. It was first necessary to form an eminence, that the building might rise above the plain and might be seen from afar. This eminence was not hastily made by heaping up earth, but regularly and systematically built with sun-dried bricks. Thus a platform, thirty or forty feet high, was formed; and upon it they erected the royal, or sacred edifice.†

Sun-dried bricks were still the principal, but could not in this instance, for various reasons, be the only materials employed. The earliest edifices of this nature appear to have been at the same time public monuments, in which were preserved the records or archives of the nation, carved on stone. In them were represented in sculpture the exploits of the kings, or the forms of the divinities; whilst the history of the people, and invocations to their gods, were also inscribed in written characters upon the walls.

ing and of fishing. After them came two brothers; one of them, Chrysor or Hyphæstus, was the first who sailed in boats; his brother invented the way of making walls with bricks. From this generation were born two youths, one called Technites, and the other Genius Autochthon. *They discovered the method of mingling stubble with the loam of the bricks, and drying them in the sun; they also invented tiling."*

* Chap. v.

† Such is the custom still existing amongst the inhabitants of Assyria. When some families of a nomad tribe wish to settle in a village, they choose an ancient mound; it being no longer necessary to form a new platform, for the old abound in the plains. On its summit they erect a rude castle, and the huts are built at the foot. This course appears to have been followed since the Arab invasion, and perhaps long previous, during the Persian occupation. There are few ancient mounds containing Assyrian ruins which have not served for the sites of castles, cities, or villages built by Persians or Arabs. Such are Arbela, Tel Afer, Nebbi Yunus, &c., &c.

It was necessary, therefore, to use some material upon which figures and inscriptions could be carved. The plains of Mesopotamia, as well as the low lands between the Tigris and the hill-country, abound in a kind of coarse alabaster or gypsum. Large masses of it every where protrude in low ridges from the alluvial soil, or are exposed in the gullies formed by winter torrents. It is easily worked, and its color and transparent appearance are agreeable to the eye. Whilst offering few difficulties to the sculptor, it was an ornament to the edifices in which it was placed. This alabaster, therefore, cut into large slabs, was used in the public buildings.

The walls of the chambers, from five to fifteen feet thick, were first constructed of sun-dried bricks. The alabaster slabs were used as panels. They were placed upright against the walls, care being first taken to cut on the back of each an inscription recording the name, title, and descent of the king undertaking the work. They were kept in their places and held together by iron, copper, or wooden cramps and plugs. The cramps were in the form of double dovetails, and fitted into corresponding grooves in two adjoining slabs.* The corners of the chambers were generally formed by one angular stone; and all the walls were either at right angles, or parallel to each other.

The slabs having been fixed against the walls, the subjects to be represented upon them were designed and sculptured, and the inscriptions carved. That the Assyrian artists worked

* Every slab has this groove of a dovetail shape on the edges: but there were besides three round holes at equal distances between them. I am unable to account for their use—whether to receive plugs which were in some way connected with the superstructure, or rods of metal which may have extended through the wall to the slab in the adjoining chamber. Only one of the dovetails (of iron) remained in its place. These cramps appear to have been used (according to Diodorus Siculus) at Babylon; the stones of the bridge, said to have been built by Semiramis, being united by them. Herodotus (lib. i. c. 186) also states that the stones of the bridge built over the Euphrates by Nitocris were joined by iron and lead. Similar cramps made of lead and wood, inscribed with the name of the king, are found in Egyptian buildings as early as the xviii—xix dynasty.

after the slabs had been fixed, appears to be proved beyond a doubt, by figures and other parts of the bas-reliefs being frequently finished on the adjoining slab; and by slabs yet unsculptured being found, placed in one of the buildings at Nimroud.*

The principal entrances to the chambers were, it has been seen, formed by gigantic winged bulls and lions with human heads. The smaller doorways were guarded by colossal figures of divinities, or priests. No remains of doors or gates were discovered, nor of hinges; but it is probable that the entrances were provided with them. The priests of Babylon "made fast their temples with doors, with locks and bars, lest their gods be spoiled by robbers,"† and the gates of brass of Babylon are continually mentioned by ancient authors. On all the slabs forming entrances, in the oldest palace of Nimroud, were marks of a black fluid, resembling blood, which appeared to have been daubed on the stone. I have not been able to ascertain the nature of this fluid; but its appearance cannot fail to call to mind the Jewish ceremony, of placing the blood of the sacrifice on the lintel of the doorway. Under the pavement slabs, at the entrances, were deposited small figures of the gods, probably as a protection to the building.‡ Sometimes, as in the early edifices, tablets containing the name and title of the king, as a record of the time of the erection of the building, were buried in the walls, or under the pavement.

* This mode of sculpturing the stone after placing it appears to have been generally the custom in Egypt and India.

† Epistle of Jeremy. Baruch, vi. 18.

‡ It has already been mentioned, that these small figures in unbaked clay, were found beneath the pavement in all the entrances at Khorsabad. They were only discovered at Nimroud in the most recent palace, in the southwest corner of the mound. See p. 36 of this volume. M. Botta conjectures that the copper lion, discovered at Khorsabad between the bulls forming the entrance, was chained to the large sculptures by a chain of copper or bronze, fastened to the ring on the back of the animal. But the size of the smallest of those found at Nimroud (Vol. I. p. 120) seems to preclude this supposition. It is remarkable, however, that almost every slab forming an entrance has a hole in the centre, as if intended for a ring or bolt.

The slabs used as a panelling to the walls of unbaked brick rarely exceeded twelve feet in height; and in the earliest palace of Nimroud were generally little more than nine; whilst the human-headed lions and bulls, forming the doorways, vary from ten to sixteen. Even these colossal figures did not complete the height of the room; the wall being carried some feet above them. This upper wall was built either of baked bricks, richly colored, or of sun-dried bricks covered by a thin coat of plaster, on which were painted various ornaments. It could generally be distinguished in the ruins. The plaster which had fallen, was frequently preserved in the rubbish, and when first found the colors upon it had lost little of their original freshness and brilliancy. It is to these upper walls that the complete covering up of the building, and the consequent preservation of the sculptures, may be attributed; for when once the edifice was deserted they fell in, and the unbaked bricks, again becoming earth, incased the whole ruin. The principal palace at Nimroud must have been buried in this manner, for the sculptures could not have been preserved as they were, had they been covered by a gradual accumulation of the soil. In this building I found several chambers without the panelling of alabaster slabs. The entire wall had been plastered and painted, and processions of figures were still to be traced. Many such walls exist to the east and south of the same edifice, and in the upper chambers.*

The roof was probably formed by beams, supported entirely by the walls; smaller beams, planks, or branches of trees, were laid across them, and the whole was plastered on the outside with mud. Such are the roofs in modern Arab cities of Assyria. It has been suggested that an arch or vault was thrown from wall to wall. Had this been the case, the remains of the vault, which must have been constructed of baked bricks or of stone, would have been found in the ruins, and would have partly filled up the chambers. No such remains were

* Plan 4, p. 19, of this volume.

discovered.* The narrowness of the chambers in all the Assyrian edifices, with the exception of one hall (Y, plan 3,) at Nimroud, is very remarkable. That hall may have been entirely open to the sky; and, as it did not contain sculptures, it is not improbable that it was so; but it can scarcely be conceived that the other chambers were thus exposed to the atmosphere, and their inmates left unprotected from the heat of the summer sun, or from the rains of winter. The great narrowness of all the rooms, when compared with their length, appears to prove that the Assyrians had no means of constructing a roof requiring other support than that afforded by the side walls. The most elaborately ornamented hall at Nimroud, although above 160 feet in length, was only 35 feet broad. The same disparity is apparent in the edifice at Kouyunjik.† It can scarcely be doubted that there was some reason for making the rooms so narrow; otherwise proportions better suited to the magnificence of the decorations, the imposing nature of the colossal sculptures forming the entrances, and the length of the chambers, would have been chosen. But still, without some such artificial means of support as are adopted in modern architecture, it may be questioned whether beams could span 45, or even 35 feet. It is possible that the Assyrians were acquainted with the principle of the king-post of modern roofing, although in the sculptures the houses are represented with flat roofs: otherwise we must presume that wooden pillars or posts were employed; but there were no indications whatever of them in the ruins. Beams, supported by opposite walls, may have met in the centre of the ceiling. This may account for the great thickness of some of the partitions. Or in the larger halls a projecting ledge, sufficiently wide to afford shelter and

* M. Flandin (*Voyage Archéologique à Ninive, in the Revue des Deux Mondes*) states that he found sufficiently large masses of kiln-burnt bricks in the chambers at Khorsabad, to warrant the supposition that the roof had been vaulted with them. But I am inclined to doubt this having been the case; and I believe M. Botta to be of my opinion.

† Some of the chambers at Kouyunjik were about 45 feet wide.

shade, may have been carried round the sides, leaving the centre exposed to the air. Remains of beams were every where found at Nimroud, particularly under fallen slabs. The wood appeared to be entire, but when touched it crumbled into dust. It was only amongst the ruins in the southwest corner of the mound, that any was discovered in a sound state.

The only trees within the limits of Assyria sufficiently large to furnish beams to span a room 30 or 40 feet wide, are the palm and the poplar; their trunks still form the roofs of houses of Mesopotamia. Both easily decay, and will not bear exposure; it is not surprising, therefore, that beams made of them should have entirely disappeared after the lapse of 2,500 years.

The poplar now used at Mosul is floated down the Khabour and Tigris from the Kurdish hills;* it is of considerable length, and occasionally serves for the roofs of chambers nearly as wide as those of the Assyrian palaces.

It has been seen that the principle of the arch was known to the Assyrians,† a small vaulted chamber of baked bricks having been found at Nimroud; but there are no traces of an arch or vault used on a large scale.

If daylight were admitted into the Assyrian palaces, it could only have entered from the roof. There are no communications between the inner rooms except by the doorways, consequently they could only receive light from above. Even in the chambers next to the outer walls, there are no traces of win-

* Vol. I. p. 149.

† Arched gateways are continually represented in the bas-reliefs. According to Diodorus Siculus, the tunnel under the Euphrates at Babylon, attributed to Semiramis, was also vaulted. Indeed, if such a work ever existed, it may be presumed that it was so constructed. It was cased on both sides, that is, the bricks were covered with bitumen; the walls were four cubits thick. The width of the passage was 15 feet; and the walls were 12 feet high to the spring of the vault. The rooms in the temple of Belus, were, according to some, arched and supported by columns. The arch first appears in Egypt about the time of the commencement of the eighteenth dynasty (Wilkinson's *Ancient Egyptians*, vol. ii. p. 117), or when, as it has been shown, there existed a close connection between Egypt and Assyria.

dows.* It may be conjectured, therefore, that there were square openings or skylights in the ceilings, which may have been closed during winter rains by canvas, or some such material. The drains, leading from almost every chamber, would seem to show that water might occasionally have entered from above, and that apertures were required to carry it off. This mode of lighting rooms was adopted in Egypt; but, I believe, at a much later period than that of the erection of the Nimroud edifices. No other can have existed in the palaces of Assyria, unless, indeed, torches and lamps were used; a supposition scarcely in accordance with the elaborate nature of the sculptures, and the brilliancy of the colored ornaments; which, without the light of day, would have lost half their effect.

The pavement of the chambers was formed either of alabaster slabs, covered with inscriptions recording the name and genealogy of the king, and probably the chief events of his reign, or of kiln-burnt bricks, each also bearing a short inscription. The alabaster slabs were placed upon a thin coating of bitumen spread over the bottom of the chamber, even under the upright slabs forming its sides. The bricks were laid in two tiers, one above the other; a thin layer of sand being placed between them, as well as under the bottom tier. These strata of bitumen and sand may have been intended to exclude damp; although the buildings, from their position, could scarcely have been exposed to it. Between the lions and bulls forming the entrances, was generally placed one large slab, bearing an inscription.

I have already alluded† to the existence of a drain beneath

* It is possible that some of the chambers, particularly if devoted to religious purposes, were only lighted by torches, or by fires fed by bitumen or naphtha. This custom appears to be alluded to in the Epistle of Jeremy. "Their faces are blackened through the smoke that cometh out of the temple." (Baruch, vi. 21.) But no traces of smoke or fire were found on the sculptures and walls of the earliest palace of Nimroud.

† P. 67 of this volume.

almost every chamber in the older palace of Nimroud. These were connected with the floor by a circular pipe of baked clay, leading from a hole, generally cut through one of the pavement slabs, in a corner of the room. They joined one large drain, running under the great hall (Y, in plan 3,) and from thence into the river, which originally flowed at the foot of the mound.

The interior of the Assyrian palace must have been as magnificent as imposing.* I have led the reader through its ruins, and he may judge of the impression its halls were calculated to make upon the stranger who, in the days of old, entered for the first time the abode of the Assyrian kings. He was ushered in through the portal guarded by the colossal lions or bulls of white alabaster.† In the first hall he found himself surrounded by the sculptured records of the empire. Battles, sieges, triumphs, the exploits of the chase, the ceremonies of religion, were portrayed on the walls, sculptured in alabaster, and painted in gorgeous colors. Under each picture were engraved, in characters filled up with bright copper, inscriptions describing the scenes represented. Above the sculptures were painted other events—the king, attended by his eunuchs and warriors, receiving his prisoners, entering into alliances with other monarchs, or performing some sacred duty. These representations were inclosed in colored borders, of elaborate and elegant design. The emblematic tree, winged bulls, and monstrous animals, were conspicuous amongst the ornaments. At the upper end of the hall was the colossal figure of the king in adoration before the supreme deity, or receiving from his eunuch the holy cup. He was at-

* According to Moses of Chorene (lib. i.), the palaces in Armenia at the earliest period were built by Assyrian workmen, who had already attained to great skill in architecture. The Armenians thus looked traditionally to Assyria for the origin of some of their arts.

† In the palace of Scylas in the city of the Borysthenites, against which Bacchus hurled his thunderbolt, were placed *sphinxes and gryphons of white marble*, (Herod. lib. iv. c. 79.)

tended by warriors bearing his arms, and by the priests or presiding divinities. His robes, and those of his followers, were adorned with groups of figures, animals, and flowers, all painted with brilliant colors.

The stranger trod upon alabaster slabs, each bearing an inscription, recording the titles, genealogy, and achievements of the great king. Several doorways, formed by gigantic winged lions or bulls, or by the figures of guardian deities, led into other apartments, which again opened into more distant halls. In each were new sculptures. On the walls of some were processions of colossal figures—armed men and eunuchs following the king, warriors laden with spoil, leading prisoners, or bearing presents and offerings to the gods. On the walls of others were portrayed the winged priests, or presiding divinities, standing before the sacred trees.

The ceilings above him were divided into square compartments, painted with flowers, or with the figures of animals. Some were inlaid with ivory, each compartment being surrounded by elegant borders and mouldings. The beams, as well as the sides of the chambers, may have been gilded, or even plated, with gold and silver; and the rarest woods, in which the cedar was conspicuous, were used for the wood-work.* Square openings in the ceilings of the chambers ad-

* Sun-dried bricks, with the remains of gilding, were discovered at Nimroud. Herodotus states that the battlements of the innermost walls of the royal palace of Ecbatana, the ornaments of which were most probably imitated from the edifices of Assyria, were plated with silver and gold (lib. i. c. 98); and the use of gold in the decorations of the palaces of the East is frequently mentioned in ancient authors. Even the roofs of the palace at Ecbatana are said to have been covered with silver tiles. The gold, silver, ivory, and precious woods in the roofs of the palaces of Babylon, attributed to Semiramis, are frequently mentioned by ancient writers. Thus, in the *Periegesis* of Dionysius, v. 1005–1008.—

“ πρὸς δὲ νότον, Βαβυλῶν ἱερὴ πόλις· ἦν βὰ τε πᾶσαν
 τείχεσιν ἀββαγίσσι Σεμίραμις ἐστεφάνωσεν·
 αὐτὰρ ἐπ’ ἀκροπόλει μέγαν ὄβρον εἴσατο Βήλω,
 χρυσῶ τ’ ἠδ’ ἐλεφάντι καὶ ἀργύρῳ δοκῆσασα.”

mitted the light of day. A pleasing shadow was thrown over the sculptured walls, and gave a majestic expression to the human features of the colossal forms which guarded the entrances. Through these apertures was seen the bright blue of an eastern sky, inclosed in a frame on which were painted, in vivid colors, the winged circle, in the midst of elegant ornaments, and the graceful forms of ideal animals.*

These edifices, as it has been shown, were great national monuments, upon the walls of which were represented in sculpture, or inscribed in alphabetic characters, the chronicles of the empire. He who entered them might thus read the history, and learn the glory and triumphs of the nation. They served, at the same time, to bring continually to the remembrance of those who assembled within them on festive occasions, or for the celebration of religious ceremonies, the deeds of their ancestors, and the power and majesty of their gods.

Translated by Priscian, v. 950-953.—

“ Ad partes Austri Babylon. quam mœnibus olim
Mirandis posuit firmisque Semiramis urbem ;
Cujus in arce domum splendidem fecerit auro,
Quam simul argentum varie decoravit eburque.”

And by Rufus Festus Avienus (*Orbis Descriptio*, v. 1196-1201.)—

“ Quæ sunt fabra Noti, Babylon subducitur arce
Procera in nubes : hanc prisca Semiramis urbem
Vallavit muris quos non absumere flammæ
Non areis penetrare queat ; stat maxima Beli
Aula quoque argento, domus Indo dente niteascit,
Aurum tecta operit ; sola late contegit aurum.”

Zephaniah (xi. 14) alludes to the “ cedar work ” of the roof ; and in Jeremiah (xxii. 14) chambers “ ceiled with cedar and painted with vermilion ” are mentioned. It is probable that the ceilings were only panelled or wainscotted with this precious wood. (1 Kings, vi. 15, vii. 3.) The ceilings of Egyptian tombs and houses were like those described in the text. (*Wilkinson's Ancient Egyptians* vol. ii. p. 125.) The ivory ornaments found in some of the chambers at Nimroud may possibly have belonged to the ceiling.

* I have endeavored, with the assistance of Mr. Owen Jones, to give, in my work on the Monuments of Nineveh, a representation of a chamber or hall as it originally appeared. I have restored the details from fragments found during the

It would appear that the events recorded in the buildings hitherto examined, apply only to the kings who founded them. Thus, in the earliest palace of Nimroud, we find one name constantly repeated; the same at Kouyunjik and Khorsabad. In some edifices, as at Kouyunjik, each chamber is reserved for some particular historical incident; thus, on the walls of one, we find the conquest of a people residing on the banks of two rivers, clothed with groves of palms, the trees and rivers being repeated in almost every bas-relief. On those of a second is represented a country watered by one river, and thickly wooded with the oak or some other tree. In the bas-reliefs of a third we have lofty mountains, their summits covered with firs, and their sides with oaks and vines. In every chamber the scene appears to be different.

It was customary in the later Assyrian monuments to write, over the sculptured representation of a captured city, its name, always preceded by a determinative letter or sign.* Short inscriptions were also generally placed above the head of the king in the palace at Kouyunjik, preceded by some words apparently signifying "this is," and followed by others giving his name and title. The whole legend probably ran, "This is such an one (the name), the king of the country of Assyria." At Khorsabad similar short inscriptions are frequently found above less important figures, or upon their robes; a practice which, it has been seen, prevailed afterwards amongst the Persians.† I may observe, that in the earliest

excavations, and from parts of the building still standing. There is full authority for all except the ceiling, which must remain a subject of conjecture. The window or opening in it has been placed immediately above the winged lions, to bring it into the plate; but it is probable that it was in the centre of the hall. The larger chambers may have had more than one such opening.

* This sign, which I have given, in note, p. 167, appears to be the first letter of a word signifying city or castle, or to be a monogram for the word. Dr. Hincks traces in it a rude representation of a rampart and parapet. (On the Inscriptions of Van, p. 29.)

† On the great rock-tablet of Behistun we have not only the name and genealogy of Darius written over his head, but also the name and country of the prisoners placed above each.

palace of Nimroud, such descriptive notices have never been found introduced into the bas-reliefs.

Were these magnificent mansions palaces or temples? or, whilst the king combined the character of a temporal ruler with that of a high-priest or type of the religion of the people, did his residence unite the palace, the temple, and a national monument raised to perpetuate the triumphs and conquests of the nation? These are questions which cannot yet be satisfactorily answered. We can only judge by analogy. The religious character of the king is evident from a very casual examination of the sculptures. The priests or presiding deities (whichever the winged figures so frequently found on the Assyrian monuments may be) are represented as waiting upon, or ministering to him; above his head are the emblems of the divinity—the winged figure within the circle, the sun, the moon, and the planets. As in Egypt, he may have been regarded as the representative, on earth, of the deity; receiving his power directly from the gods, and the organ of communication between them and his subjects.* All the edifices hitherto discovered in Assyria, have precisely the same character; so that we have most probably the palace and temple combined; for in them the deeds of the king, and of the nation, are united with religious symbols, and with the statues of the gods.

Of the exterior architecture of these edifices, no traces remain. I examined as carefully as I was able the sides of the great mound at Nimroud, and of other ruins in Assyria; but there were no fragments of sculptured blocks, cornices, columns, or other architectural ornaments, to afford any clue to the nature of the façade. It is probable that as the building was raised on a lofty platform, and was conspicuous from all parts of the surrounding country, its exterior walls were either cased with sculptured slabs or painted. This mode of deco-

* Diodorus Siculus, lib. i. c. 90, and Wilkinson's *Ancient Egyptians*, vol. i. p. 245, and vol. ii. p. 67.

rating public buildings appears to have prevailed in Assyria. On the outside of the principal palace of Babylon, built by Semiramis, were painted, on bricks, men and animals; even on the towers were hunting scenes, in which were distinguished Semiramis herself on horseback, throwing a javelin at a panther, and Ninus slaying a lion with his lance.* The walls of Ecbatana, according to Herodotus,† were also painted in different colors. The largest of these walls (there were seven round the city) was white, the next was black, the third purple, the fourth blue, the fifth orange. The two inner walls were differently ornamented, one having its battlements plated with silver, the other with gold.‡ At Khorsabad a series of alabaster slabs, on which were represented gigantic figures bearing tribute, appeared to M. Botta to be an outer wall, as there were no remains of building beyond it. It is possible that the sculptures on the edge of the ravine in the northwest palace of Nimroud, also apparently captives bearing tribute, may have formed part of the north façade of the building, opening upon a flight of steps, or upon a road leading from the river to the great hall.§

We may conjecture, therefore, that the outer walls, like the inner, were cased with sculptured slabs below, and painted with figures of animals and other devices above; and thus ornamented, in the clear atmosphere of Assyria, their appearance would be far from unpleasing to the eye. They were probably protected by a projecting roof; and, in a dry climate, they would not quickly suffer injury from mere exposure to the air. The total disappearance of the alabaster slabs, may be easily accounted for by their position. They would probably have

* Diodorus Siculus, lib. ii.

† Lib. i. c. 98.

‡ These colors, with the number seven of the walls, have evidently allusion to the planets and their courses. (Herod. l. i. c. 98.) Seven disks are frequently represented as accompanying the sun, moon, and other religious emblems at Nimroud.

§ D and E, plan 3, and see Vol. I, p. 117.

remained outside the building, when the interior was buried; or they may have fallen to the foot of the mound, where they soon perished, or where they may perhaps still exist under the accumulated rubbish.*

On the western face of the mound of Nimroud, at the foot, I discovered many large square stones, which probably cased the lower part of the building, or rather of the mound itself. Xenophon, describing the ruins, says that the lower part of the walls was of stone to the height of 20 feet; the upper being of brick†. The stones he saw were merely the casing, the interior or body of the walls being built of sun-dried bricks.

Although there were houses in Assyria of two and three stories in height, as at Babylon,‡ and as represented in the sculptures of Kouyunjik,§ yet it does not appear probable that the great buildings just described, had more than a ground floor. If there had been upper rooms, traces of them would still be found, as is shown by the discovery of the chambers on the western face of the mound.|| Had they fallen in, some remains of them would have been left in the lower rooms.

The houses and towers represented in some of the later sculptures, have windows and doors ornamented with cornices. We have no means of ascertaining the forms of the chambers, nor of learning any particulars concerning their internal eco-

* The thickness of both the outer walls and the walls forming partitions between the chambers, may have contributed greatly to exclude the heat and to keep the chambers cool. It was Mr. Longworth's impression, on examining the ruins, that there never had been any exterior architecture, but that all the chambers had been, as it were, subterranean, resembling the serdabs, or summer apartments, of Mosul and Baghdad. But such a supposition does not appear to me consistent with the magnificent entrances, and with the elevated position of the building. Had underground apartments been contemplated, an artificial platform would scarcely have been raised to receive them.

† Anab. lib. iii. c. iv. s. 7.

‡ Herod. lib. i. c. 180.

§ At Nimroud, although there were towers represented in the bas-reliefs, with windows evidently belonging to the upper stories, yet there were no houses of two stories.

|| See p. 19 of this volume.

nomy and arrangement. No private houses, either of Assyria Proper or Babylonia, have been preserved. The complete disappearance of private dwellings, as it has been shown, is mainly to be attributed to the perishable materials of which they were constructed. The mud-built walls returned to dust as soon as exposed, without occasional repair, to the effects of the weather—to rain, the heat of the sun, or hot winds. The traveller in Assyria may still observe the rapid decay of such edifices. He may search in vain for the site of a once flourishing village a few years after it has been abandoned.

It would appear from the Assyrian sculptures that tents were in common use, even within the walls of a city. There are frequent representations of inclosures, formed by regular ramparts and fortifications, partly occupied by such habitations, in which are seen men, and articles of furniture, couches, chairs, and tables.

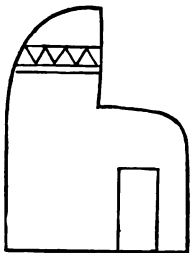

A House.* (Kouyunjik.)

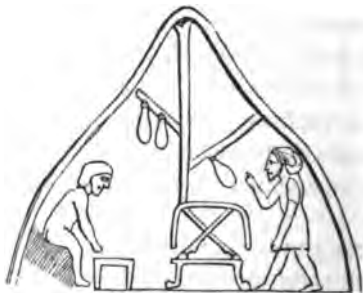

Interior of a tent. (Kouyunjik.)

In the tent represented in the woodcut, jars appear to be suspended to the poles, to cool the water within. Such is now the practice in the East. It is still not an uncommon custom, in the countries included in ancient Assyria and Babylonia, for

* This house appears to resemble the model of an Egyptian dwelling in the British Museum. (See also Sir Gardner Wilkinson's *Ancient Egyptians*, vol. ii. woodcuts 98 and 99.) From a bas-relief discovered in the centre of the mound at Nimroud, it would appear that the upper part was sometimes formed of canvas.

wandering tribes to encamp at certain seasons of the year within the walls of cities. In Baghdad, Mosul, and the neighboring towns, the tents of Arabs and Kurds are frequently seen amongst the houses; and such it would appear was the case in Assyria in the earliest ages. Abraham, and Lot, resided in tents in the midst of cities. Lot had his house in Sodom, as well as his tents. We find continual mention of persons having tents, and living within walls at the same time.* In the districts around Mosul, the inhabitants of a village frequently leave their houses during the spring, and seek a more salubrious air for themselves, and pasture for their flocks, on the hills or plains. I have frequently alluded to this custom in the previous volume.

The absence of the column, amongst the ruins of Assyria, is remarkable. It would appear that the Assyrians did not employ this useful architectural ornament; indispensable, indeed, in the construction of the roofs of halls exceeding certain proportions. That they could not have been unacquainted with it is proved by pillars being represented, supporting a pavilion or tent, in the older sculptures of Nimroud. They were probably of wood, appear to have been painted, and were surmounted by a pine or fir cone, that religious symbol so constantly recurring in the Assyrian monuments.† But the first indication of the use of columns in buildings, is to be found in the sculptures of Khorsabad. In a bas-relief from that ruin, a temple, fishing pavilion, or some building of the kind, is seen standing on the margin, or actually in the midst of, a lake or river. The façade is embellished by two columns, the capitals

* These tents were probably made of black goat-hair, like those of the modern Arabs—"I am *black*, but comely, O ye daughters of Jerusalem, as the tents of Kedar" (Cant. i. 5)—and were not the gay white pavilions which are usually seen in modern Biblical illustrations.

† An engraving from a bas-relief, showing such columns, will be included in my work on the Monuments of Nineveh; and the bas-relief itself will be placed in the British Museum.

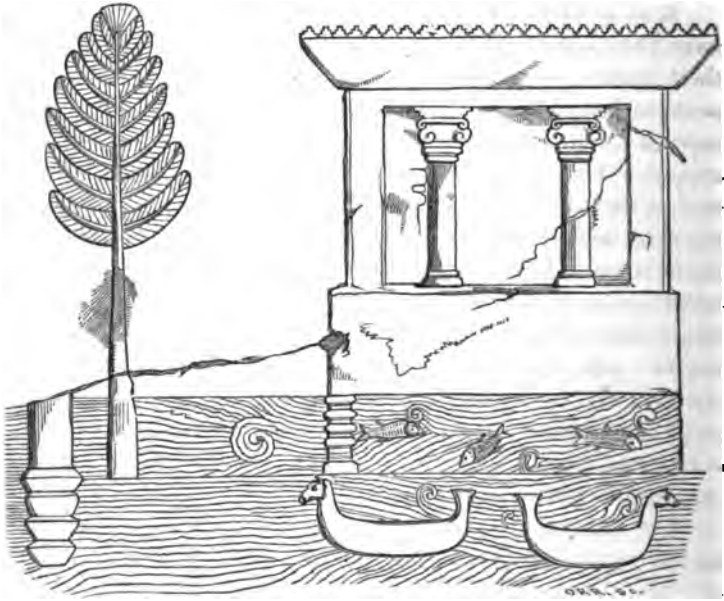

A Temple or Fishing Pavilion supported by Proto-Ionic Columns, and standing in a River or artificial Lake. (Khorsabad.)

of which so closely resemble the Ionic, that we can scarcely hesitate to recognize in them the prototype of that order.*

In a bas-relief at Kouyunjik, the entrance to a castle was flanked by two similar columns. The city represented, appeared to belong to a maritime people inhabiting the shores of the Mediterranean, and may perhaps be identified (as it will hereafter be shown) with Tyre or Sidon. We have therefore the Ionic column on monuments of the eighth, or seventh, century before Christ.

* On an ivory tablet from Nimroud, the capitals of pillars, supporting a kind of frame inclosing a head, also nearly resemble the Ionic; but less so than those given in the woodcut. They have, however, the egg and tongue ornament under the helices. The lower part of the pine or fir cone, surmounting the columns of wood described in the previous page, has also much the appearance of the volute of the Ionic.

It is remarkable that the column, which appears thus to have been known to the Assyrians, was not used generally in their buildings. That it was not, unless merely of wood, appears to be proved by the absence of all remains of shafts and capitals; and in Eastern ruins these are the last things to disappear. The narrowness of the chambers, also, as I have observed, must be attributed to the want of means of supporting a ceiling, exceeding in width the span of an ordinary poplar or palm beam. It is possible that a conventional architecture, invested, as in Egypt, with a religious character, was introduced before the knowledge of the column. Hence, at a subsequent period, when this useful ornament was otherwise in common use, it was not admitted into sacred buildings. But, as far as I am aware, no remains of the column, which cannot be distinctly referred to a period subsequent to the Greek occupation, have yet been found in Assyria.*

The walls of the Assyrian cities, as we learn from the united testimony of ancient authors, were of extraordinary size and height. Their dimensions, as given by Herodotus and Diodorus Siculus, have every appearance of great exaggeration; but, from the remains which still exist, it is highly probable that they exceeded in thickness any modern walls. The materials were generally bricks of clay, dried in the sun. The inhabitants could thus raise their defences rapidly, without either great toil, or the cost and labor of transport from distant places. As the earth was removed to make the bricks, a ditch was formed round the walls; at least such, we are informed, was the case at Babylon. Sometimes the walls were constructed of these bricks alone. They were even then probably of sufficient strength to resist a siege. Frequently, however, this earthen rampart was cased with stones or slabs, carefully squared and adjusted; so that those who were unacquainted with the mode in which the walls were built, believed them to be entirely of stone. Sometimes the lower part only

* Nor have any been found, I believe, amongst the ruins of Babylon.

may have been cased with stone, the upper being entirely of brick; as, according to Xenophon, were the walls of Mespila and Larissa.*

According to Diodorus Siculus the walls of Nineveh were one hundred feet high, and so broad that three chariots might be driven abreast upon them. They were furnished with fifteen hundred towers, each two hundred feet in height. Those of Babylon, according to Herodotus, were two hundred cubits (or about three hundred feet) high, and fifty cubits (or about seventy-five feet thick.† In the Book of Judith the walls of

* *Cyrop. lib. iii.* The lower part of the walls of Mespila, according to Xenophon, was fifty feet high, and as many broad, and the upper one hundred high. The plinth was of a polished stone full of shells—the limestone still abounding in the country. The base of the walls is frequently the common river conglomerate. There are no remains at Kouyunjik to show that any part of the wall was of solid stone; yet there can scarcely be a doubt that Mespila is represented by the ruins opposite Mosul. Nor does the circuit of six parasangs, mentioned by Xenophon, agree with the present dimensions, which do not amount to as many miles. Some allowance must be made for a little exaggeration.

† The walls of Babylon formed one of the standard fables of the ancients. According to some they were of brass. The Greek scholiast, upon the passage in the *Periegesis* of Dionysius (quoted p. 262), says:—"To the south (of the *Matiēni*) lies the great city of Babylon, which Semiramis crowned with unbreakable, brazen or strong, walls; for the wall is said to be brazen, for it was on every side flanked by the river." Eustathius, commenting on the same passage of Dionysius, observes:—"In the south of Mesopotamia is Babylon, the Persian metropolis, a sacred city surrounded with a brazen wall according to some, and with a river flowing round it; all of which, he says, Semiramis crowned with unbreakable walls. Where some, forsooth, as it has been said, have narrated that the wall was of brass, and have put forth many other marvels about it, besides those above explained," &c. "Some say that when Ninus, king of (As-) Syria founded Nineveh, his wife, in order to surpass her husband, built Babylon in the plain with baked bricks, asphalt, and hewn stones three cubits broad and six long. Its perimeter was 355 stadia; the walls were forty cubits high and thirty broad, so that chariots could pass one another, and were flanked with gates with lofty towers. And she made brazen doors of a great height." According to Josephus, who quotes Berosus, Nebuchadnezzar built three walls round the interior, and three round the exterior of Babylon, or probably three round the new, and three round the old city. Within these walls were the celebrated hanging gardens. He built also high walks of stone, with all manner of trees upon them, to give the appearance of a mountain; besides which he made a paradise, which was called the hanging garden; to

Ecbatana are stated to have been seventy cubits in height, and fifty broad, or corresponding in thickness with those of Babylon. They were built of hewn stones, six cubits long and three broad; and the gates, "for the going forth of the mighty armies (of Nebuchadnezzar) and for the setting in array of the footmen," were seventy cubits high and forty wide.*

Of these enormous structures, allowing for exaggeration, and inaccuracy, in the statements of the Greek historians,† there are still certain traces. They do not, however, inclose the space attributed to either Babylon or Nineveh, but form quadrangular inclosures of more moderate dimensions, which appear to have been attached to the royal dwellings, or were perhaps intended as places of refuge in case of siege. Such are the remains of Nimroud, Kouyunjik, and Khorsabad; and those on the left bank of the river Euphrates, near Hillah, the site of the Babylon of Nebuchadnezzar. These walls are now marked by consecutive mounds, having the appearance of ramparts of earth hastily thrown up. On examination, however, they are found to be regularly constructed of unbaked bricks. In height they have, of course, greatly decreased, and are still gradually decreasing, but the breadth of their base proves their former magnitude; and that they were of great strength, and able to resist the engines of war then in use, we learn from the fact that Nineveh sustained a siege for nearly three years in the time of Sardanapalus, and could only be taken by the combined armies of the Persians and Babylonians when the river had overflowed its bed, and had carried away a part of the wall. According to Xenophon, Larissa was captured during the consternation of the inhabitants caused by an eclipse of the sun.

please his wife, who, coming from Media, loved a mountainous country. (Against Apion, book i.)

* Chap. i. v. 1-4.

† The walls of Nineveh were built, according to Eustathius, in eight years, by 140,000 men. Those of Babylon in fifteen. (Berosus, Frag.) According to Quintus Curtius, a stadium was finished each day. (lib. v. c. 26.)

At certain distances in the walls there were gates, sometimes flanked, as at Kouyunjik, by towers adorned with sculptures, and sometimes formed by gigantic figures, such as the winged bulls and lions. An entrance of this kind has recently been by chance exposed to view, in the mounds forming the quadrangle at Khorsabad. The lofty pyramidal structures, which still exist at Nimroud, Kalah Sherghat, and Khorsabad, may have been used, as it has been already observed, as watchtowers. In the edifices of Nineveh, bitumen and reeds were not employed to cement the layers of bricks, as at Babylon; although both materials are to be found in abundance in the immediate vicinity of the city.* The Assyrians appear to have made much less use of bricks baked in the furnace than the Babylonians; no masses of brickwork, such as are every where found in Babylonia Proper, existing to the north of that province. Common clay moistened with water, and mixed with a little stubble, formed, as it does to this day, the mortar used in buildings. But, however simple the materials, they have successfully resisted the ravages of time, and still mark the stupendous nature of the Assyrian structures.

* Rich, however, mentions stones cemented with bitumen, as having been found in an excavation amongst the ruins opposite Mosul.

CHAPTER III.

THE remarks in the foregoing chapter, on the architecture of the Assyrians, naturally lead to the consideration of the state of the arts in general amongst them. It is impossible to examine the monuments of Assyria without being convinced, that the people who raised them had acquired a skill in sculpture and painting, and a knowledge of design and even composition, indicating an advanced state of civilization. It is very remarkable, that the most ancient ruins show this knowledge in the greatest perfection, attained by the Assyrians. The bas-relief representing the lion-hunt, now in the British Museum, is a good illustration of the earliest school of Assyrian art yet known. It far exceeds the sculptures of Khorsabad, Kouyunjik, or the later palaces of Nimroud, in the vigor of the treatment, the elegance of the forms, and in what the French aptly term "mouvement." At the same time it is eminently distinguished from them by the evident attempt at composition,—by the artistical arrangement of the groups. The sculptors who worked at Khorsabad, and Kouyunjik, had perhaps acquired more skill in handling their tools. Their work is frequently superior to that of the earlier artist, in delicacy of execution—in the details of the features, for instance—and in the boldness of the relief; but the slightest acquaintance with Assyrian monuments will show, that they were greatly inferior to their ancestors in the higher branches of art—in the treatment of a subject, and in beauty and variety of form. This decline of art, after suddenly attaining its greatest perfec-

tion in its earliest stage, is a fact presented by almost every people, ancient and modern, with which we are acquainted. In Egypt, the most ancient monuments display the purest forms, and the most elegant decorations. A rapid retrogression, after a certain period, is most apparent, and serves to indicate approximately the epoch of most of her remains. In the history of Greek and Roman art, this sudden rise and rapid fall are equally apparent. Even changes in royal dynasties have had an influence upon art; as a glance at monuments of that part of the East of which we are specially treating will show. Thus the sculpture of Persia, as that of Assyria, was in its best state at the time of the earliest monarchs, and gradually declined until the fall of the empire. After the Greek invasion, it revived under the first kings of the Arsacid branch; Greek taste still exercising an influence over the Iranian provinces. How rapidly art degenerated to the most barbarous forms, the medals and monuments of the later Arsacids abundantly prove. When the Sassanians restored the old Persian monarchy, and endeavored to restore the ancient religion and sacred ceremonies of the empire, art again appears to have received a momentary impulse. The coins, gems, and rock sculptures of the first kings of this dynasty, are distinguished by considerable elegance, and spirit of design, and beauty of form. But the decay was as rapid under them, as it had been under their predecessors. Even before the Khosraws raised the glory and power of the empire to its highest pitch, art was fast degenerating. By the time of Yezdigird, it had become even more rude, and barbarous, than in the last days of the Arsacids.

This decline in art may be accounted for by supposing that, in the infancy of a people, or after the occurrence of any great event, having a very decided influence upon their manners, their religion, or their political state, nature was the chief, if not the only, object of study. When a certain proficiency had been attained, and no violent changes took place to shake the established order of things, the artist, instead of endeavoring

to imitate that which he saw in nature, received as correct delineations the works of his predecessors, and made them his types and his models. In some countries, as in Egypt, religion may have contributed to this result. Whilst the imagination, as well as the hand, was fettered by prejudices, and even by laws, or whilst indolence or ignorance led to the mere servile copying of what had been done before, it may easily be conceived how rapidly a deviation from correctness of form would take place. As each copied the errors of those who preceded him, and added to them himself, it is not wonderful if, ere long, the whole became one great error. It is to be feared, that this prescriptive love of imitation has exercised no less influence on modern art, than it did upon the arts of the ancients.

As the earliest specimens of Assyrian art which we possess are the best, it is natural to conclude that either there are other monuments still undiscovered, which would tend to show a gradual progression, or that such monuments did once exist, but have long since perished; otherwise it must be inferred, that those who raised the Assyrian edifice, derived their knowledge directly from another people, or merely imitated what they had seen in a foreign land. Some are inclined to look upon the style, and character of these early sculptures, as purely Egyptian. But there is such a disparity in the mode of treatment, and in the execution, that the Egyptian origin of Assyrian art appears to me, to be a question open to considerable doubt. That which they have in common would mark the first efforts of any people, of a certain intellectual order, to imitate nature. The want of relative proportions in the figures, and the ignorance of perspective—the full eye in the side face, and the warriors fighting, and the bodies of the dead scattered above, or below the principal figures,—are as characteristic of all early productions of art, as they are of the rude attempts at delineation of children. It is only in the later monuments of Nineveh, that we find evident and direct traces of Egyptian influence; as in the sitting sphinxes and ivories of Nimroud

and in the lotus-shaped ornaments of Khorsabad and Kouyunjik; perhaps also in the custom which then prevailed of inserting the name of the king, or of the castle upon, or immediately above, their sculptured representations. Neither the ornaments of the earliest palace of Nimroud, nor the costumes, nor the elaborate nature of the embroideries upon the robes, with the groups of human figures and animals, nor the mythological symbols, are of an Egyptian character; they show a very different taste and style.

The principal distinction between Assyrian, and Egyptian art appears to be, that in the one, conventional forms were much more strictly adhered to than in the other. The angular mode of treatment so conspicuous in Egyptian monuments, even in the delineation of every object, is not perceivable in those of Assyria. Had the arts of the two countries been derived from the same source—or had one been imitated from the other—they would surely have displayed the same striking peculiarity. The Assyrians, less fettered, sought to imitate nature more closely, however rude and unsuccessful their attempts may have been; and this is proved by the constant endeavor to show the muscles, veins, and anatomical proportions of the human figure.

We must not lose sight of the assertion of Moses of Chorene—derived no doubt from ancient traditions, if not from direct historical evidence—that when Ninus founded the Assyrian empire, a people far advanced in civilization, and in the knowledge of the arts and sciences, whose works the conquerors endeavored to destroy, were already in possession of the country.* Who that people may have been, we cannot now even conjecture. The same mystery hangs over the origin of the arts in Egypt, and in Assyria. They may have been derived, before the introduction of any conventional forms, from a common source—from a people whose very name, and the proofs of

* Before the foundation of Nineveh, Ninus, according to a tradition preserved by Stephen of Byzantium, resided in a city called Telané.

whose former existence, may have perished even before tradition begins.

The monuments of Assyria furnish us with very important data, as to the origin of many branches of art, subsequently brought to the highest perfection in Asia Minor, and Greece. I conceive the Assyrian influence on Asia Minor to have been twofold. In the first place, direct, during the time of the greatest prosperity of the Assyrian monarchy or empire, when, as it has been shown, the power of its kings extended over that country; in the second, indirect, through Persia, after the destruction of Nineveh. Of the influence exercised upon the arts of western Asia, during the early occupation of the Assyrians, few traces have hitherto been discovered, unless the remarkable monuments on the site of ancient Pteria or Pterium belong to this period.* The evident connection between the divinities, and sacred emblems worshipped in various parts of Asia Minor, and those of Assyria, will be hereafter particularly pointed out. The Assyrian origin of these monuments, and of these religious symbols, once admitted, we shall have no difficulty in recognizing the influence of Assyria on the arts and customs of Asia Minor. The antiquities of that country prior to a well-known period, the Persian occupation, have been but little investigated. Few remains of an earlier epoch have yet been discovered. That such remains do exist, perhaps buried under ground, I have little doubt. It is most probable that when we have additional materials for inquiry, we shall be still more convinced of this Assyrian influence, pointed out by Herodotus, when he declares the founder of the kingdom of Lydia to have been a descendant of Ninus, and by other authors who mention the Syrian, or Assyrian descent of many nations of Asia Minor.†

* Texier, *L'Asie Mineure*, pl. 75, 79. There appears to be now little doubt that the celebrated rock-tablet on the road from Ephesus to Phocæa, and between Sardis and Smyrna, described by Herodotus, and attributed by him to Sesostris (lib. ii. c. 106), was not an Egyptian, but an Assyrian monument. It was the Chevalier Lepsius, I believe, who first questioned the Egyptian origin of that at Nymphi.

† There are reasons for conjecturing that Pterium, itself, was not unconnected

But the second, or indirect, period of this influence, is very fully and completely illustrated by the monuments of *Asia Minor*, of the time of the Persian domination. The known connection between these monuments, and the archaic forms of Greek art, renders this part of the inquiry both important and interesting. The Xanthian marbles, acquired for this country by Sir Charles Fellows, and now in the British Museum, are remarkable illustrations of the threefold connection between Assyria and Persia, Persia and Asia Minor, and Asia Minor and Greece. Were those marbles properly arranged, and placed in chronological order, they would afford a most useful lesson, and would enable even a superficial observer to trace the gradual progress of art, from its primitive rudeness to the most classic conceptions of the Greek sculptor. Not that he would find either style, the pure Assyrian or the Greek, in its greatest perfection; but he would be able to see

with Assyria. According to Stephen of Byzantium, the same name was given to the Acropolis of Babylon (in voce *Ἰνρίπιον*). The inhabitants of Cappadocia were Leuco-Syrians, or white Syrians. According to several ancient geographers, the city of Melita in that province was founded by Semiramis; as also Comana, on the Sarus, and Zela in Pontus. (Pliny, vi. 3; Strabo, xii. 385 and 389.) Thyatira, on the Lycus, in Mysia, was also originally named Semiramis. We have a people called Chaldæans, mentioned by Xenophon and Strabo, as found near the Black Sea. Apollonius Rhodius (lib. ii. c. 965) and Strabo speak of the Assyrians on the Halys, and Dionysius (Perieg. 772) as inhabiting the north of Asia Minor. According to Stephen of Byzantium, Ninus founded a city, called after him Ninœ (afterwards Aphrodesias or Megalopolis), on the frontiers of Lydia and Caria; the same city is mentioned by Suidas. There was another city of the same name in the district of Commagena in Syria. The building of Tarsus, and Anchiale, by Sardanapalus, must also be borne in mind; and the curious tradition, preserved by Eusebius from Abydenus, that Sennacherib built a temple at Athens, placing brass monuments in it, on which were inscribed his deeds. (Eusebius, Chron. book i. c. 9.) The same author points out another close connection between Assyria and Asia Minor, and Greece, when he states that Axerdis, having killed his brother Adrameles, pursued his army as far as Byzantium. In the army of Axerdis, was Pythagoras, who was acquiring the wisdom of the Chaldees. When Sardanapalus was besieged by the allied army of the Medes, Babylonians, and Bactrians, he sent his three sons and two daughters, with large treasures of gold and silver, to Cottus governor of Paphlagonia, who had remained faithful to him.

how a closer imitation of nature, a gradual refinement of taste, and additional study, had converted the hard and rigid lines of the Assyrians, into the flowing draperies, and classic forms of the highest order of art.*

I have termed this second period that of *indirect* influence, because the arts did not then penetrate directly into Asia Minor from Assyria; but were conveyed thither through the Persians. The Assyrian empire had already existed for centuries, and had exercised the supreme power over Asia, before it was disputed by the kingdoms of Persia and Media, united under one monarch. The Persians were probably a rude people, possessing neither a literature nor arts of their own, but deriving what they had from their civilized neighbors.† We have no earlier specimen of Persian writing than the inscription containing the name of Cyrus, on the ruins supposed to be those of his tomb, at Murghaub; nor any earlier remains of Persian art than the buildings and sculptures of Persepolis, and other monuments to be attributed beyond a question to the kings of the Achæmenian dynasty. It has already been shown that the writing of the Persians was imitated from the Assyrians, and it can as easily be proved that their sculptures were derived from the same source. The monuments of Persepolis establish this beyond a doubt.† They exhibit precisely the same mode of treatment, the same forms, the same peculiarities in the arrangement of the bas-reliefs against the walls,

* It is hoped that some chronological system will be adopted in the arrangement of all the works of art in the British Museum; for no collection in Europe, whatever may be its completeness in any particular department, has a more full and comprehensive *series* of monuments, giving the whole history of art, in its earliest stage, its most classic period, and its decline—from the most ancient period of Egypt and Assyria, to the time of the transfer of the seat of the Roman Empire to Constantinople. A series so arranged would be invaluable; not only as affording the means of studying the history of art, but as giving no ordinary insight into the history of the human race.

† This would appear from the statements both of Herodotus and Xenophon.

‡ See particularly the works of Sir R. K. Porter, of Flandin and Coste, and of Texier.

the same entrances formed by gigantic winged animals with human heads, and, finally, the same religious emblems. Had this identity been displayed in one instance alone, we might have attributed it to chance, or to mere casual intercourse; but when it pervades the whole system, we can scarcely doubt that one was a close copy, an imitation, of the other. That the peculiar characteristics of the Persepolitan sculptures were derived from the monuments of the second Assyrian dynasty—that is, from those of the latest Assyrian period—can be proved by the similarity of shape in the ornaments, and in the costume of many of the figures. Thus, the head-dress of the winged monsters forming the portals is lofty, squared, and richly ornamented at the top, resembling those of Khorsabad and Kouyunjik, and differing from the round, unornamented cap of the older figures at Nimroud.*

The processions of warriors, captives, and tribute-bearers at Persepolis, are in every respect similar to those on the walls of Nimroud and Khorsabad; we have the same mode of treatment in the figures, the same way of portraying the eyes and hair. The Persian artist introduced folds into the draperies; but, with this exception, he certainly did not improve upon his Assyrian model. On the contrary, his work is greatly inferior to it in the general arrangement of the groups, and in the elegance of the details.

From whence the Persians obtained the column, and other architectural ornaments used at Persepolis, it may be more difficult to determine. We have seen that the column was not unknown to the later Assyrians, although it does not appear to have been employed in the construction of their palaces. The Persians, therefore, may have partly derived their knowledge from them, and partly, perhaps principally, from the Egyptians;

* For the rounded cap of the most ancient Assyrian monuments, see the wood cuts of the colossal winged lion and bull in the first volume. In Alexander's "Travels from India to England," pl. ix., there is an engraving of a bas-relief of a winged lion discovered at Persepolis, which even more closely resembles the Assyrian than the larger figures in the works of Ker Porter, and Flandin and Coste.



HEAD OF WINGED BULL.
(Khorsabad and Kouyunjik.
p. 228.



HEAD OF WINGED MONSTER.
(Persepolis. p. 228.



HANDLE OF THREE DAGGERS.
Carried in the Girdle. p. 234.



ORNAMENT.
(N. W. palace, Nim-
roud.) p. 233.



ORNAMENT. (N. W. palace, Nimroud.) p. 233.
228. VOL. II.

NEW YORK
1911

whom, before the foundation of Persepolis, they had already conquered. It will be observed that the capitals of their columns frequently assume the shape of Assyrian religious types, the bull for instance; whilst other portions of them nearly resemble in the form of their ornaments, though not in their proportions, those of Egypt.

The Persians introduced into Asia Minor the arts, and religion, which they received from the Assyrians. Thus the Harpy Tomb, and the monument usually attributed to Harpagus at Xanthus, and other still earlier remains, show all the peculiarities of the sculpture of Persepolis, and at the same time that gradual progress in the mode of treatment—the introduction of action and sentiment, and a knowledge of anatomy—which marks the distinction between Asiatic and Greek art. Whilst there was a manifest improvement in the disposition of the draperies, and in the delineation of the human form, we still remark, even in the latest works of the Persian period in Asia Minor, the absence of all attempt to impart sentiment to the features, or even to give more than the side view of the human face.

There is one monument, however, from Xanthus, which particularly deserves notice, from its connection with Persian and Assyrian art and religious emblems. I allude to the fragment of a tomb in the British Museum, on which is represented a figure struggling with, and piercing, a rampant lion.



Fragment of a Lydian Monument in the British Museum.

The sculpture is so peculiarly Assyrian in its treatment, identical representations being found on the monuments and cylinders of Assyria, that there can be no doubt as to its origin. The combat with the lion was either a pure religious type or a symbol of the power and wisdom of the king, which, first devised by the Assyrians, was afterwards

used by the Persians, and is every where to be found on their monuments.

I add another illustration—a bas-relief from the Harpy Tomb, conjectured to represent the three Graces between Juno and Venus. The forms of the chairs and the general treatment is Assyrian. The calf sucking the cow, originally an Assyrian emblem, occurs on an altar in a bas-relief discovered at Khorsabad, and is found among the ivories from Nimroud.*



Bas-Reliefs from a Monument from Xanthus in the British Museum.

The connection between art as introduced by the Persians into Asia Minor, and the sculpture and architecture of Greece, is out of the scope of this volume. The subject has been more than once successfully treated. It is, I believe, now generally admitted, how much, in the early stage of art, the Greeks were indebted to their intercourse with that country. However, the Greek sculptor was not a mere imitator, as the Persian had been: adopting that which was most beautiful in the works of others, he made it his own, and by a gradual process of development produced, ere long, those severe and graceful

* I am indebted to the kindness of Mr. Scharf for the two woodcuts from Lycian monuments.

forms, which were the foundation of the most noble monuments of human genius.*

It has already been mentioned that many architectural ornaments, known to the Assyrians, passed from them, directly or indirectly, into Greece. The Ionic column has been cited as an instance. We have, moreover, in the earliest monuments of Nineveh, that graceful ornament, commonly called the honey-suckle, which was so extensively used in Greece, and is to this day more generally employed than any other moulding. In Assyria, as I have pointed out, it was invested with sacred properties, and was either a symbol or an object of worship.



Assyrian Ornament. (Nimroud.)



Greek Honey-suckle Ornament.



Greek Honey-suckle Ornament.

That the similarity between the Assyrian and Greek ornament is not accidental, seems to be proved beyond a question, by the alternation of the lotus or tulip, whichever this flower may be, with the honey-suckle; by the number of leaves or petals of the flower, and by their proceeding in both from a semi-circle, supported by two tendrils or scrolls.† The same ornament occurs, even in India, on a lath erected by Asoka at Allahabad (about b. c. 250); but whether introduced by the Greeks—which, from the date of the erection of the monument,

* The resemblance between several archaic sculptures, particularly one representing a warrior holding a spear, discovered five or six years ago (I believe) at Athens, and similar figures at Persepolis, is very remarkable. There is an engraving of this warrior in an *Archæological Journal* (*Ephemeris Archæiologiché*) published in the Greek capital. (See also the *Revue Archéologique* for 1844, plate 1, p. 49.)

† I have given in my work on the *Monuments of Nineveh*, several specimens of this ornament; one from a painting on the walls of the northwest palace.

shortly after the Macedonian invasion, is not improbable—or whether derived directly from another source, I cannot venture to decide.*



On a Lath at Allahabad.

That the Assyrians possessed a highly refined taste can hardly be questioned, when we find them inventing an ornament which the Greeks afterwards, with few additions and improvements, so generally adopted in their most classic monuments. Others, no less beautiful, continually occur in the most ancient bas-reliefs of Nimroud. The sacred bull, with expanded wings, and the wild goat, are introduced kneeling



Ornament. (N. W. Palace, Nimroud.)

before the mystic flower, which is the principal feature in the border just described. The same animals are occasionally represented supporting disks, or flowers and rosettes. A bird, or human figure, frequently takes the place of the bull and goat; and the simple flower becomes a tree, bearing many flowers of the same shape. This tree, evidently a sacred sym-

* I am indebted to Mr. Fergusson, the author of the beautiful work on the Temples of India, for a sketch of this ornament.

bol, is elaborately and tastefully formed; and is one of the most conspicuous ornaments of Assyrian sculpture.

The flowers at the ends of the branches are frequently replaced in later Assyrian monuments, and on cylinders, by the fir or pine cone, and sometimes by a fruit or ornament resembling the pomegranate.*

The guilloche, or intertwin- ing bands, continually found on Greek monuments, and still in common use, was also well known to the Assyrians, and was one of their most favor- ite ornaments. It was em- broidered on their robes, em- bossed on their arms and char- iots, and painted on their walls.

This purity, and elegance of taste, was equally display- ed in the garments, arms, fur- niture, and trappings of the Assyrians.

The robes of the king were most elaborately em- broidered. The part cover- ing his breast was generally adorned, not only with flow- ers and scroll-work, but with groups of figures, animals, and even hunting and battle

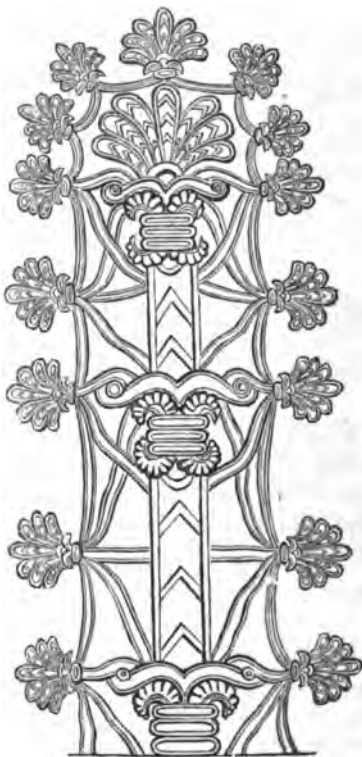

Sacred Tree. (N. W. Palace, Nimroud.)

* Such perhaps was "the net-work with pomegranates," one of the principal ornaments in the temple of Solomon. (1 Kings, vii. 41, 42.) The pomegranate was worked on the garments of Aaron. (Exodus, xxviii. 33, 34.) It was evidently a sacred symbol, and was connected with the god Rimmon. A deity, supposed by Achilles Tattius (lib. iii.) to be Zeus or Jupiter, was represented in a temple at Pe- lusium holding a pomegranate in his hand.

scenes.* In other parts of his dress similar designs were introduced; and rows of tassels or fringes were carried round the borders. The ear-rings, necklaces, armlets, and bracelets were all of the most elegant forms. The clasps, and ends of the bracelets were frequently in the shape of the heads of rams and bulls, resembling our modern jewelry. The ear-rings have generally on the later monuments, particularly in the bas-reliefs of Khorsabad, the form of a cross.

In their arms, the Assyrians rivalled even the Greeks in elegance of design. The hilt of the sword was frequently ornamented with four lions' heads; two, with part of the neck and shoulders, made the cross-bar or defence, and two more with extended jaws were introduced into the handle. The end of the sheath was formed by two entire lions, clasped together, their heads turned outwards, and their mouths open. Sometimes the whole of the sheath was engraved, or embossed, with groups of human figures, animals, and flowers.

The handles of the daggers were no less highly ornamented, being sometimes in the form of the head of a horse, bull, or ram. The sheath frequently terminated in the head of a bird, to which a tassel was suspended. The part of the bow to which the string was attached, was in the shape of an eagle's head. The quiver was richly decorated with groups of figures, and fanciful designs.

Ornaments, in the form of the heads of animals, chiefly the lion, bull, and ram, were very generally introduced even in parts of the chariot, the harness of the horses, and domestic furniture. In this respect the Assyrians resembled the Egyptians.

Their tables, thrones, and couches were made both of metal and wood, and probably inlaid with ivory. We learn from Herodotus, that those in the temple of Belus at Babylon,

* Details from these embroidered robes will be given in my work on the Monuments of Nineveh. These designs can scarcely have been engraved upon a breast-plate of metal, as the sculptor has made no distinction between the upper and lower part of the king's dress. They may represent the linen breast-plates, worn by the Assyrians in the army of Xerxes. (Herod. i. vii. c. 63.)

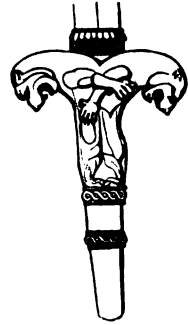

ASSYRIAN EAR-RINGS. (Khorsabad.) Page 234. EAR-RING. (N. W. palace, (Khorsabad.) Page 234. NIMROUD.) EAR-RING. (N. W. palace, (Khorsabad.) Page 234. NIMROUD.) END OF A SWORD SHEATH. (Khorsabad.) Page 234. NIMROUD.)



CUP WITH HANDLE. (Khorsabad.) Page 236.

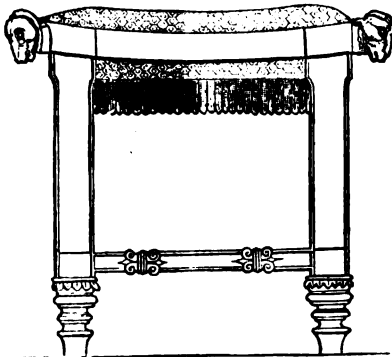

A THRONE OR STOOL. (N. W. Palace. Nimroud.) Page 234.

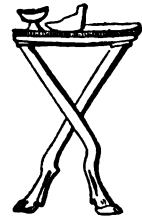

A TABLE. (N. W. Palace. Nimroud.) Page 236.



A STOOL. (Khorsabad.) Page 236.



AN ARM-CHAIR. (Khorsabad.) Page 236.

WORK
ARY.
AND
IONS.

were of solid gold.* The chair represented on the earliest monuments is without a back, the legs are tastefully carved, and the seat is adorned with the heads of rams. The cushion appears to have been made of some rich stuff, embroidered or painted. The legs were strengthened by a cross-bar, and frequently ended in the feet of a lion, or the hoofs of a bull, either of gold, silver, or bronze.† On the monuments of Khorsabad, and in the rock-tablets of Malthaiyah, we find representations of chairs supported by animals, and by human figures, sometimes prisoners, like the Caryatidæ of the Greeks. In this they resembled the arm-chairs of Egypt, but appear to have been more massive.

This mode of ornamenting the throne of the king was adopted by the Persians, and is continually seen in the sculptures of Persepolis. The lion was both an ornament and support, in the throne of Solomon. "And there were stays (or arms) on either side on the place of the seat, and two lions

* The couch, or bedstead, as our version has it, of Og, king of Basan, was of iron. (Deut. iii. 11.)

† The bed of Solomon was of the wood of Lebanon; the posts were of silver, the bottom of gold, and the curtains of purple. (Song of Solomon, iii. 9, 10.) Chairs and couches, adorned with feet of silver, and other metals, were looked upon as a great object of luxury in Persia; from thence they were probably introduced into Asia Minor, and Greece. Artaxerxes presented Entimos Gortyna, who had gone to him from Greece, with "a couch having silver feet, and with all the furniture that appertained to it, and with a dome-shaped tent, or curtain, worked with flowers, and a silver seat and gilded dome; and with cups, bottles, and other things of gold inlaid with jewels and of silver." (Athenæus, lib. ii. c. 48.) In fact, this was a complete bed, probably something like the modern French bed and its furniture, accompanied by such objects as were required for the toilette. The court of the garden of the palace of Ahasuerus, when he feasted the people in Shushan the palace, was fitted up "with white, green, and blue hangings, fastened with cords of fine linen and purple, to silver rings and pillars of marble; the couches were of gold and silver, upon a pavement of red, and blue, and white, and black marble (or mosaic)." (Esther, i. 6.) The feet of the couch, on which the body of Cyrus was placed in his tomb, were of solid gold. (Arrian, vi. 29.) The couches and tables found by Pausanias in the tents of Mardonius, were of gold and silver. They had belonged to Xerxes. (Herod. i. ix. c. 82.) Couches wreathed with ivory and silver, and the beds variegated or inlaid with gold, silver, and ivory, are mentioned by Homer. (Od. xix. 55, 56, and xxiii. 199.)

stood beside the stays (or arms). And twelve lions stood there, on the one side and on the other upon the six steps."* This description corresponds with the Assyrian chairs, the arms of which are frequently supported by the figures of animals.†

The forms of the furniture represented in the bas-reliefs of the later period, as at Khorsabad, display less taste and elegance than those of the earlier monuments. The chairs have generally more than one cross-bar, and are somewhat heavy and ill-proportioned, the feet resting upon large inverted cones, resembling pine-apples. The seats were high, the feet of those who sat upon them being raised considerably above the ground; a footstool was consequently necessary. On the earliest Assyrian monuments the shape of the footstool is very beautiful; like the chair, it was ornamented with the paws of lions, or the hoofs of bulls.‡

The tables and chairs were frequently shaped like our camp stools, and may have been made to close: they were also generally terminated by the feet of animals.

The drinking cups, and vessels, used on festive occasions, were probably of gold, like those of Solomon,§ or of silver. When Ahasuerus feasted all the people, both great and small, for seven days in Shushan the palace, wine was given to them in vessels of gold, each one differing from the other.|| The drinking vases of the Assyrians were frequently wrought into the shape of the head and neck of an animal—such as a lion or a bull,—and resembled those afterwards in use amongst the Greeks, and found in the tombs of Etruria.

None of the vases discovered at Nimroud are, perhaps,

* 1 Kings, x. 19, 20.

† In the Lycian sculptures we have examples of similar supports to the chairs. The fashion was probably introduced into Asia Minor by the Persians, who originally borrowed it from the Assyrians.

‡ The footstool of Solomon's throne was of gold. (2 Chron. ix. 18.)

§ 1 Kings, x. 21: "And all king Solomon's drinking vessels were of gold, and all the vessels of the house of the forest of Lebanon were of pure gold: none were of silver; it was nothing accounted of in the days of Solomon."

|| Esther, i. 7.

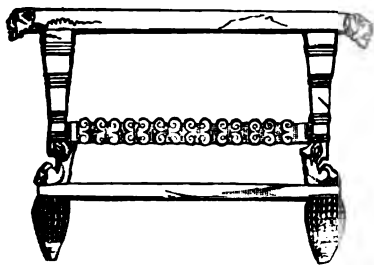

A COUCH OR TABLE. (Khorsabad) p. 246

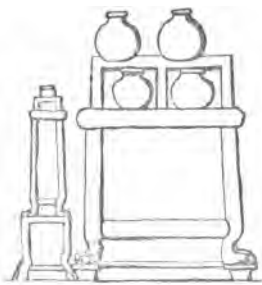
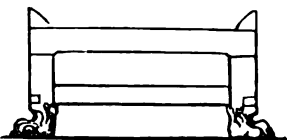

TABLE WITH TWO VASES ON TOP
(N. W. Palace, Nimroud.)
p. 236



BOOT WITH LACING
(Khorsabad) p. 261



FOOTSTOOL SUPPORTED BY LION'S
PAWS. (N. W. Palace, Nimroud.)
p. 236.



VASE
FROM A PALACE
(Khorsabad) p. 237.



DRINKING CUP
(Khorsabad) p. 237.



BASKET OR VESSEL CAR-
RIED BY WINGED FIG-
URES. (Khorsabad.)
p. 237.



HEAD-DRESS OF THE
KING. (N. W. Palace,
Nimroud.) p. 248.



HEAD-DRESS OF
THE KING
(Koufunjik)
p. 248.



A SANDAL. (Khorsabad) p. 261.



A SANDAL
(N. W. Palace, Nimroud.) p. 261.



HELMETS. (Centre Palace, Nimroud.) p. 262.



236. VOL. II.



CIRCULAR HELMET.
(Centre Palace,
Nimroud.) p. 262.

WORK
AND
CONTRIBUTIONS.

purely Assyrian. Those of alabaster and glass, from the north-west palace, bearing the name of the Khorsabad king, closely resemble the Egyptian, as do the earthen jars from the tombs.* In the bas-reliefs, however, we have occasional representations of vases ; some carried by attendants, who appear to be waiting at feasts, and others borne by captives, as objects of tribute. In shape they are not wanting in beauty, bearing some resemblance to Greek pottery, of a period succeeding the ruder archaic.

The square basket, or utensil, so frequently represented in the Assyrian sculptures, as carried by the winged figures, is generally very elaborately decorated. In the early bas-reliefs of Nimroud, a group of figures is often introduced upon it, and the margin is richly adorned with the honeysuckle ornament, or with the intertwining bands. The corners to which the handle is attached, are frequently in the form of eagles. In the sculptures of Khorsabad, this square utensil is made to represent a basket or wicker-work ; but in the early sculptures it appears to be of metal.

The arms, domestic furniture, utensils, personal ornaments, and details I have described, show a very refined and cultivated taste. In this respect, the most ancient Assyrian monuments with which we are acquainted, greatly exceed the later. Many forms had been preserved, as in the swords, bracelets, and armllets ; but they had evidently degenerated, and are more coarsely designed in the sculptures. This is also evident in the embroideries of the robes, and in the details of the chariots. We see the same love of elaborate and profuse decoration, but not that elegance and variety, so conspicuous in the ornaments of the first period. The kneeling bull or wild goat, the graceful flower, and the groups of men and animals skilfully combined, are succeeded by a profusion of rosettes,

* Mr. Birch suggests that the alabaster vases were brought from Egypt. Amongst the Asiatic nations who bring tribute to Thothmes III. are the Kheva, who offer vases of gold and silver, somewhat similar to those described in the text. (Hoskins' *Æthiopia* ; Wilkinson's *Ancient Egyptians*, vol. i. pl. iv. First Series.)

circles, and squares, covering the whole surface of the dress, or the sides of the chariots. Although there is a certain richness of appearance, yet the classic forms, if the term may be used, of the earlier artists, are wanting.

It is remarkable that the later Assyrians, whilst retaining ancient forms in their arms, should have discontinued their use in the embroideries of their robes; no longer introducing the groups of figures, which previously formed so elegant and important an ornament. This can scarcely be ascribed to a mere modification of taste. As all these groups have evident reference to myths, and sacred subjects, their omission appears to confirm the conjecture that an essential change had taken place in the religious system, as well as in the manners, of the Assyrians, between the construction of the earliest and latest monuments.

The bas-reliefs and sculptures of the Assyrians, except, probably, those in black marble and basalt, were either partly or entirely painted. I could not ascertain whether the ground, as well as the figures, had been colored; but M. Flandin states* that he could trace on the bas-reliefs of Khorsabad a tint of yellow ochre on all parts not otherwise painted. It is not improbable that such was the case, particularly in the Khorsabad and Kouyunjik palaces, as a similar practice existed in Egypt. There were fewer remains of color at Nimroud, than in the ruins explored by M. Botta. I could distinguish them on the hair, beard, and eyes, on the sandals and bows, on the tongues of the eagle-headed figures, and very faintly on a garland round the head of a winged priest, and on the representation of fire in the bas-relief of a siege. These traces being only found on certain parts of the human face, and on particular objects, almost lead to the conjecture that the earliest Assyrian sculptures were but partially colored. At Khorsabad the remains of paint were far more general, being found on the draperies, the mitre of the king, the flowers carried by the

* In his "Voyage Archéologique à Ninive," in the *Revue des Deux Mondes*

winged figures, the harness of the horses, the chariots, and the trees. In the bas-reliefs representing a siege, the flames issuing from the houses, and the torches carried by the assailants, were invariably colored red.

The passage in Ezekiel, describing the interior of the Assyrian palaces, so completely corresponds with, and illustrates, the monuments of Nimroud and Khorsabad, that it deserves particular notice in this place. The prophet, in typifying the corruptions which had crept into the religious systems of the Jews, and the idolatrous practices borrowed from nations with whom they had been brought into contact, thus illustrates the influence of the Assyrians. "She saw men portrayed upon the wall, the images of the Chaldeans portrayed with vermilion, girded with girdles upon their loins, exceeding in dyed attire upon their heads, all of them princes to look to, after the manner of the Babylonians of Chaldea, the land of their nativity."* Ezekiel, it will be remembered, prophesied on the banks of

* Ch. xxii. ver. 14 and 15. This description of the Assyrian sculptures is very remarkable. The literal translation of the passage is: "She saw men of sculptured (or painted) *workmanship* upon the wall, likenesses of the Chaldeans, pictured (or sculptured) in shashar; girded with girdles on their loins, with colored *flowing head-dresses* upon their heads, *with the aspect* of princes all of them, *the likeness* of the sons of Babel-Chaldæa, the land of their nativity." The words in *Italics* are not in the text. *Shashar* occurs also in Jeremiah, xxii 14, where it is rendered in our version "vermilion." Gesenius translates it "red color, red ochre, rubrica;" the Vulgate "sinopis," *i. e.* rubrica sinopensis, which was the most celebrated (Plin. Hist. Nat. xxxv. 5, 13); the Septuagint *μῖλρος*, which in Homer is rubrica. All the commentators, the Septuagint, and the Syrian and Chaldee versions, give to Shashar the meaning of a color. The Rabbis make it "cinnabar," which is near to vermilion. There is an Arabic root شزر (Shazar), from which Shuzret, redness of the eyes, and Eahzer, ruddy of appearance, seem to be derived. The root itself, however, as a verb, does not include the idea of redness; but has, amongst other analogous meanings, that of "twisting a rope," and that of "piercing a man," from which the idea of sculpturing might be derived. It means also "to raise" and "be raised," and might be applied to bas-relief work. This agrees with the original meaning of the Hebrew חקק (hakek), to cut, to engrave, to sculpture; perhaps an onomatope, like our word "to hack." But in Jeremiah, xxxii. 14, there is "daubed with shashar:" here it would appear to mean a paint, unless a painted bas-relief is intended. And the hieroglyphic word for red is "teether,"

the Chebar, a river which, whether it can be identified with the Khabour of the Arabs (the Chaboras of the Greeks), flowing through the plains of Mesopotamia, and falling into the Euphrates near Karkemish (Circesium), or with another of the same name rising in the mountains of Kurdistan, and joining the Tigris above Mosul, was certainly in the immediate vicinity of Nineveh. In the passage quoted, the prophet is referring to a period previous to the final destruction of the Assyrian capital, an event which he most probably witnessed, as the date usually assigned to his prophecies is 593 before Christ, only thirteen years after the Medo-Babylonian conquest. There can scarcely be a doubt that he had seen the objects which he describes—the figures sculptured upon the wall, and painted. The prevalence of a red color, shown by the Khorsaban remains, and the elaborate and highly ornamented head-dress of the Khorsabad and Kouyunjik kings, are evidently indicated. The evidence thus afforded of the existence of these monuments before the fall of Nineveh, taken in connection with the prophet's subsequent description of the complete overthrow and destruction of the city,* is a convincing proof, were any

the *v* and *sh* being interchangeable. The word סְרוּחָה (serouhâ) means any thing, especially of woven stuff or leather, which hangs over; and appears in the text to denote a head-dress falling down behind, like that of many of the figures in the bas-reliefs. The word rendered colored (tebouleem), appears to be a passive participle of טָבַל, "to immerse," or "to dye;" but then there is no noun for head-dress itself, and this word would appear to designate it. If it be a noun, its meaning may be inferred from the Æthiopic root תִּטְבַּל (titbelal), "to wrap," or "wind around," and "flowing turbans upon their heads" would be the proper translation. In the various versions we have—Septuagint, Codex Rom. παραβάτται; the Codex Alex. Theodoret., Arab. Vers. and the Syriac Vers. of Origen's Hexapla, τιάραι παρραι; the Vulgate, "tiaras tinctas;" the Syriac version, "crowned with winding head-dresses;" the Chaldee version, "they took their helmets down;" Symmachus, Syriac from the Hexapla, "veil;" Theodotion, Syriac from the Hexapla, "cidarees inclinatae." It will be observed that all the non-Semitic translators take the word "tebouleem" for colored, according to the obvious meaning of the word in Hebrew; while the Semitic translators depart from the Hebrew meaning, and incline to the Æthiopic, "to wind around," or neglect the word altogether.

* Ch. xxxi.

required that the edifices described in the previous pages must be referred to a period preceding the Persian invasion.

The only colors first used in Assyria, like those employed by all nations to give effect to their earliest efforts, both in sculpture and architecture, were probably blue, red, yellow, black, and white. The tints formed by their combinations may have been adopted at a later period. There is even reason to doubt whether the green on the walls of some of the older monuments of Nimroud was not a decomposed blue. However, upon bricks from the northwest palace, there are apparently shades of colors, probably produced by an intermixture of two or more pigments; we have thus a purple, a violet, a rich brown, &c. On the sculptures I have only found black, white, red, and blue; and these colors alone were used in the painted ornaments of the upper chambers at Nimroud. At Khorsabad, green and yellow continually occurred on the bas-reliefs; at Kouyunjik, there were no traces whatever of color.

Sir Gardner Wilkinson* has given an analysis of the colors of the Egyptians, by which it would appear that the blue is a pulverized blue glass, made by vitrifying the oxides of copper and iron with sand and soda. The bright blue of the Assyrian monuments appears to be a purer oxide of copper; and its resemblance to an ore of that mineral, found in very minute crystals in an ancient mine in Kurdistan, has already been mentioned.† The Egyptian green was a mixture of a yellow ochre with the vitreous blue; and I conjecture that the green of the later monuments of Assyria, was formed by a similar admixture of ochre with the blue oxide of copper.

The Assyrian red exceeds in brilliancy that of Egypt, which

* *Ancient Egyptians*, vol. iii. p. 301.

† Vol. I. p. 189. Amongst the objects of tribute mentioned in the statistical tablet of Karnak, as having been brought from Babel or Babylon, are ingots of a substance, the nature of which appears to be doubtful, but which Mr. Birch seems inclined to believe represents some ore producing a blue color; perhaps the copper ore described in my visit to the Tiyari mountains. (*Loc. cit.*) It is mentioned on the Egyptian monuments as also coming from Saenkar (Sinjar) and from the Ruten.

was merely an earthy bole. It nearly approaches to vermilion on the sculptures of Khorsabad, and has a bright crimson or lake tint on those of Nimroud.

The black and yellow may have resembled in their composition the pigments of the Egyptians; the first a bone black, mixed with a little gum, and the second an iron ochre. The white may have been obtained, as it is to this day, by burning the alabaster or common gypsum.

But although earthy and metallic substances were used by the Assyrians, it is not improbable that vegetable colors were also known to them; they may even have been employed in painting their sculptures. Indeed their use may account for the absence of traces of color upon many parts of the bas-reliefs of Nimroud; the vegetable colors being liable to rapid decomposition on exposure either to damp or air. Dyes of the finest quality, particularly reds and greens, which even European ingenuity has been unable to equal, are obtained by the inhabitants of Kurdistan from flowers and herbs, growing abundantly in their mountains.* The art of extracting them is not a recent discovery, but has been known for ages to people living in the same country; as we learn from the frequent mention of Babylonian and Parthian dyes by ancient authors. The carpets of Kurdistan and Persia are still unrivalled, not only for the beauty of their texture, but for the brilliancy of their hues. From the ornaments on the dresses of the figures in the Assyrian sculptures, we may conclude that similar colors were extensively used, either in dyeing the garments themselves, or the threads with which the material was wove.

Some bricks from Nimroud appear to have been enamelled, the colors having been laid on very thickly when in a liquid state, and then exposed to the action of fire. Diodorus Siculus probably refers to this process, when he states that the figures of men and animals, on the walls of the palace of Semiramis at

* It is possible that the brilliant dyes of Kurdistan and parts of Persia may, to some extent, be attributed to the peculiar quality of the water.

Babylon, were painted on bricks before they were placed in the furnace.*

Although limited in the number of their colors, the Assyrians displayed considerable taste and skill in their arrangement. The contrasts are tastefully preserved, and the combinations generally agreeable to the eye.† The use of a strong black outline is a peculiar feature in Assyrian, as in Egyptian painting. Black also frequently combines with white alone, and alternates with other colors.

On the walls of chambers at Nimroud, I could trace figures painted in mere black outline upon a blue ground; it is, however, possible, that other colors originally employed had faded.

It is uncertain whether the Assyrians, like the Egyptians, used different colors to denote races, sexes, and the orders of priesthood. No trace of paint, except on the eyes and hair, has yet been found on the human body in Assyrian sculpture; unless the features of the captives leading monkeys, discovered at Nimroud, were painted black, which is very doubtful.‡

On the colossal lions and bulls forming the entrances, color only remained in the eyes, the pupils having been painted black, and the rest filled with a thick white pigment.

* Diodorus Siculus, lib. ii. c. 20. Bricks so enamelled, obtained from the earliest palace at Nimroud, are included in the collection of Assyrian antiquities, on their way to the British Museum.

† Several specimens of Assyrian colored ornaments will be given in my work on the Monuments of Nineveh. The following were the parts of bas-reliefs on which colors were found at Nimroud and Khorsabad. I give the respective colors. The hair, beard, eyebrows, eyelids, and eyeballs, black; the inner part of the eye, white; the king's mitre, principally red; the crests of helmets, blue and red; the heads of arrows, blue; the bows, red; the handles of maces, red; the harness of horses, blue and red; sandals in oldest monuments, black, edged with red; in those of Khorsabad, striped blue and red; the rosettes in the garlands of winged figures, red; trees at Khorsabad, a bluish green; flowers carried by the winged figures, green, with red flowers occasionally; fire, always red. It is probable that some of the red tints which remain were originally laid on to receive gilding. The tops of all the slabs, that part upon which it may be presumed the upper wall of sun-dried bricks rested, were painted red.

* Vol. I. p. 118.

Of the materials used by the Assyrians in the construction of their palaces, it has already been shown that a limestone or alabaster was the most common, and served to case or panel the chambers. It abounds in the country, and being very soft is easily quarried and sculptured. It is still extensively employed in the country, chiefly cut, as in the time of the Assyrians, into slabs, and forming in that state a casing to walls of sun-dried or baked bricks. The modern slabs, however, are much smaller than those found in the ruins, rarely exceeding four or five feet in length, by two or three in breadth, and being only a few inches thick. Thus shaped, they are exported to Baghdad, where they are used for the pavement of halls, and for fountains, and reservoirs, in the interior of houses. When first taken from the quarry, this alabaster is of a grayish white; but on exposure it soon changes, growing darker, and ultimately becoming a deep gray, the color of the slabs now in the British Museum. It is extremely fragile, easily decomposes, and wears away, if subjected to the action of water, or even to damp. Several slabs from Nimroud have retained the outline of the matting in which they were packed, water having penetrated into the cases. The back of the bas-relief of the eagle-headed figure in the Museum is an instance; on examination it will be seen that it is not the result of pressure, but the outline of the matting has been produced by the percolation of water, through the fissures between the rushes. The material being so very perishable, it will be a matter of surprise that the sculptures should be so well preserved, even in their minutest details. This can only be attributed to their having been suddenly buried, before exposure, and to the great accumulation of earth over them, by which they were preserved completely from damp in a country naturally dry.

On exposure to fire, this alabaster becomes of a milky whiteness, as in the ruins of Khorsabad, Kouyunjik, and the southwest corner of Nimroud. The outline of the sculptures becomes, at the same time, sharper and more defined. They have consequently a more pleasing appearance, than in the

gray slabs of the unburnt edifices ; but they crack into numberless pieces, which fall off in flakes, so that it is impossible to move, and even frequently to preserve them. The sculptures from Khorsabad in the British Museum show this appearance, and are easily distinguished by it from those of Nimroud.

The builders of the most ancient edifices at Nimroud also used a bright yellow limestone ; a pair of human-headed bulls in the northwest palace are of this material.* Another pair of similar gigantic figures once stood in the centre palace ; only fragments of them were discovered. This yellow limestone must have been brought from some distance, probably from the Kurdish hills ; but I am unable to determine the locality of the quarries. During my journey in the mountains, I observed a stone resembling it in the neighborhood of Amadiyah, but none nearer Mosul.

All the winged bulls and lions in the southwest palace were sculptured out of a coarse gray limestone.† The limestone used for the casing of the outer walls was harder and more compact, and was probably that fossiliferous stone described by Xenophon, as forming the lower part of the wall of Mespila.‡

A duck, carved in a fine-grained white marble, was discovered in the rubbish covering the northwest palace ; but no other specimen of this material was found in the ruins. The obelisk is of black marble. Vases of a pure translucent alabaster were used by the Assyrians ; but there is reason to believe that they were brought from elsewhere ; probably, as it has been conjectured, from Egypt.

The sitting figure from Kalah Sherghat, and fragments of sculpture from the same ruins, are of black basalt. This ap-

* Entrance to chamber B, plan 3. The detached head in the British Museum is a specimen.

† A detached human head of this limestone, from the southwest palace, will also be placed in the British Museum.

‡ Xenophon, *Anabasis*, l. iii. ch. 3.

pears to have been the material most generally employed in Assyria, and Babylonia, for public monuments, when alabaster and limestone were not to be obtained: in the absence of granite it may, indeed, have been preferred to any other stone, as being more durable. It abounds in the Kurdish hills, particularly in the neighborhood of Jezirah (the ancient Bezabde); and in that part of the Taurus through which the Tigris, and Euphrates, find a narrow and sudden outlet into the plains of Assyria. It is highly probable that the great obelisk, brought, according to a tradition, by Semiramis, from the mountains of Armenia, was of this material. Several figures, and fragments of sculpture in it, have been at different times discovered in Babylonian ruins. The country, for many miles round Babylon, is a recent alluvium, and no stone fit for building purposes could be reached without excavating to a very considerable depth; consequently, whilst employing generally, baked and sun-dried bricks in the construction of their edifices, the inhabitants were compelled to obtain from afar, such materials as were better calculated for the preservation of public records, and as would enable the artist to erect large and durable monuments. The black basalt of Armenia was best suited to this purpose, and could without difficulty be floated down the Euphrates and Tigris on rafts made of skins. Nearly all the monuments hitherto discovered in Babylonia are of this material.

Whether the Assyrians were acquainted with any mechanical contrivances which enabled them to bring by land, from great distances, the enormous masses of stone employed in their public monuments, cannot with any certainty be determined. That they were acquainted with the pulley at a very early period is evident, from its representation in the bas-relief of part of which I have given a sketch,* and which was originally in the most ancient palace of Nimroud. A bucket, descending into a well, is raised by a rope passing over a pulley, revolving

* Page 32 of this volume.

on an iron or wooden pin, and precisely similar in form to those now in common use.*

Amongst the sculptures at Khorsabad was, I believe, a bas-relief representing the moving of a block of stone, placed on a cart drawn by men.† Once in the plains, with the assistance of rollers and levers, no great difficulty would have been experienced in moving any of the stones hitherto discovered in the ruins; particularly as they were not sculptured until they were placed in the edifices, and in the position which they were intended to occupy; little care was therefore required in their transport. That the ancients, however, possessed mechanical means for moving large masses is evident, from the enormous blocks used in the monuments of Egypt, and from the stones forming the basement of the temple of Baalbec; built, as it is well known, many centuries before the superstructure. Although the mere physical power of large bodies of men, of which the Assyrians, like the Egyptians, had probably an almost unlimited command, went a great way in the transport of these stupendous masses, yet we cannot believe that they relied upon it alone. There are grounds for conjecturing, that they were acquainted with mechanical contrivances which are either unknown to us, or are looked upon as modern inventions. I do not mean to join, from this remark, in the oft-repeated theme of the inferiority of the moderns to the ancients, than which nothing can be more unfounded: all that it is necessary to admit is, that those who preceded us by many centuries, were not deficient in ingenuity and reflection; and that experience and study had made them familiar with many things, of which we would boast ourselves the inventors.

* The pulley was also known to the Egyptians. One, in the Museum of Leyden, is described by Sir Gardner Wilkinson, as having the sides of *athul*, or tamarisk wood, the roller of fir, and the rope of *leaf*, or fibres of the date-tree.

† This bas-relief, if amongst the collection brought by M. Flandin from Khorsabad, has not yet been published in M. Botta's work. I have some recollection of having seen a drawing of it in M. Flandin's portfolio.

CHAPTER IV.

THE Assyrians were celebrated, at a very early period, for the magnificence and luxury of their apparel. "The Assyrian garments" became almost a proverb, and having first been borrowed by the Persians, descended, at a later time, even to the Romans. These robes, as portrayed in the sculptures, confirm the traditions of their beauty and costliness. The dress of the king consisted of a long flowing garment, descending to the ankles,* elaborately embroidered, and edged with fringes and tassels. It was confined at the waist by a girdle, to which were attached cords with large tassels, falling down almost to the feet. Over this robe a second, nearly of the same length, but open in front, appears to have been thrown. It was also embroidered, and edged with tassels.† On his head he wore a high mitre or tiara of peculiar shape, reserved for the monarch alone. It is impossible, from its representation in the sculptures, to determine the nature of the material of which it was made. As it was frequently adorned with flowers and other ornaments, was worn in the temple as well as in

* The Assyrians were not ignorant of the dignity, and majesty, which flowing garments added to the figure.

"Pedes vestis defluxit ad imos,
Et vera incessu patuit Dea."

VIRG. ÆN. l. i.

† Such was probably the dress of the Babylonians as described by Herodotus. "Their clothing is of this kind: they have two vests, one of linen which falls to the feet, another over this, which is made of wool; a white sash confines the whole." (Lib. i. c. 195.)

battle, and seems to have been folded or arranged in bands, it may have been of linen, wool, or silk. Only one band passed round the head-dress of the earliest monuments; at a later period two or more were introduced, and the mitre itself was higher and more richly ornamented. These peculiarities mark, distinctly, the respective ages of sculptures, in which the figure of the king occurs.*

This mitre was surmounted by a small point or cone. In the most ancient sculptures, the ends of the band hang down the back, and are ornamented with embroideries and fringes. A kind of hood is sometimes represented as falling over the shoulders, and two long ribbons or lappets descend almost to the ankles.

Nothing remains in the bas-reliefs to indicate the materials of the robes. Like those worn at a subsequent period by the Babylonians, one may have been of linen, and the other of wool; or they may have been of cotton, or even of silk, which was an article of produce at a very early period in Assyria. They were richly embroidered and dyed. The designs upon them were most elaborate, consisting of figures of men and animals, flowers, and various devices. The part of the dress most richly ornamented was generally that which covered the breast, although groups of men and animals were introduced elsewhere. The art of embroidering figures in wool, was afterwards practised with great success by the Persians. The Medes had previously adopted the flowing robes of the Assyrians, so celebrated for their beauty, that their invention was attributed to Semiramis.†

* The Persian monarchs wore a peculiar kind of head-dress, called *cidaris*; it somewhat resembled the French cap of liberty, or the Phrygian head-dress. According to the lexicographers, only the king was privileged to wear the top erect; this was probably in imitation of the Assyrian peak. The *cidaris* of Darius was blue and white, or purple and white. (Quint. Curt. l. iii. c. 3, and l. vi. c. 6.)

† Diodorus Sic. l. ii., and Ctesias.

“Et Syriæ gentes, et laxo Persis amictu,

Vestibus ipsa suis hærens.

MANILIUS, l. iv. v. 7.

The extraordinary combinations of animal forms on these woofs are mentioned,

The neck, and the arms from a little above the elbow, were bare. More than one necklace of elegant form, was generally suspended round the neck. The arms were encircled by armlets, and the wrists by bracelets, all equally remarkable for the taste and beauty of the design and workmanship.* The clasps were in the shape of the heads of lions and other animals; and in the centre of the bracelets were stars or rosettes, which were probably inlaid with precious stones. Ear-rings of many kinds were worn; those in the form of a cross appear to have been most prevalent during the latter Assyrian period.*

In the shape and workmanship of their arms the Assyrians displayed, as it has been seen, considerable taste and skill. The king, even in time of peace, appears always to have carried a sword and two daggers. He is sometimes represented leaning, during the celebration of religious ceremonies, upon a bow, and holding two arrows in one hand. When returning

Philostrat. Imag. ii. 32, and ii. 5; and Euripides, Ion, v. 1176. Müller, Handbuck, s. 287.

The finest Persian tunic of the time of Darius was white and purple. (Quint. Curt. l. iii. c. 3.) This was the *Σάρατις*, *Περσικὴς χιτῶν*, *μασθλευκος*, of Hesychius and Pollux. We have a close imitation of the Assyrian garment in the Olympic stole as described by Apuleius (Metam. l. xi.) :—“ Et humeris dependebat, pone tergum, talorum tenuis, pretiosa chlamyda. Quaque tamen viseres, colore vario circumnotatis insignibus animalibus. Hinc dracones Indici; inde gryphes Hyperborei; quos in speciem pinnatæ alitis, generat mundus alter. Hanc Olympiadem stolam sacratî nuncupant.”

* Astyages wore a purple coat and rich habit, necklaces around his neck, and bracelets on his arms. Being pleased with the replies of Cyrus, his grandson, when first introduced to him, he presented him with similar articles of dress. (Xenophon, Cyrop. l. i. c. 3.) The golden ear-rings, peculiar to the Ishmaelites, the ornaments, collars, and purple raiment of the kings of Midian, are mentioned in Judges, viii. 26. The description given by Quintus Curtius (lib. iii. c. 3) of the dress of Darius, of his embroidered robes, golden girdle, and sword adorned with jewels, agrees well with the sculptured representation of the Assyrian king. “ Cultus regis inter omnia luxuria notabatur: purpureis tunicae medium albo intextum erat: pallam auro distinctam aurei accipitres, velut rostris inter se cœruerent, adornabant, et zona aurea muliebriter cinctus acinacem suspenderat, cui ex gemma erat vagina. Cidarim Persæ regium capitis vocabant insigne; hoc cœrulea fascia albo distincta circumibat.”

from war, he also frequently raises the two arrows; and this action appears to indicate triumph over his enemies. When not engaged in battle, he is usually portrayed at Khorsabad, and sometimes at Nimroud, with a long staff or wand in his right hand, the other resting on the hilt of his sword.

The king appears to have thrown off the outer robe during the chase, and in battle; the under garment was then confined at the waist by a broad girdle. A small apron, or square piece of linen, fell down one side of the dress over the loins, and was probably attached to the girdle; it was richly embroidered, and edged with fringe and tassels. When in battle his arms were the bow and the sword; in the sculptures he is seen using both. In a bas-relief of the later period, discovered at Nimroud, he is standing over a prostrate captive with a spear in his hand; but in no other instance, as far as I am aware, has he been found with that weapon.

The sandals worn by the king, and by his principal officers, were formed of a sole either of wood or thick leather; to which was attached an upper case covering the heel and side of the foot, but leaving exposed the instep and toes. It was fastened by bands attached to loops, and carried twice over the instep. They crossed on the top of the foot, and were passed round the great toe, and between it and the adjoining toe. In the sepulchres, a red color could generally be traced on the heel; the body of the sandal was painted black, and edged with red; the bands were black.

The sandal represented at Khorsabad, and in sculptures of the same period, is altogether of a different shape. It appears to have consisted of a simple leather covering for the heel, held by three strings passing over the instep. It was painted in the bas-reliefs, in alternate stripes of red and blue.*

* The sandals of the enemies of the Assyrians, differ from those of the Assyrians themselves. Sometimes a simple band, probably attached to a sole, passes over the instep and round the heel. Other sandals appear to resemble shoes, with a sole and upper rim united by cross-bars, between which the foot was left exposed.

The attendants upon the king, both in time of peace and war, were chiefly eunuchs; and that these persons rose to the highest rank, and were not mere servants, we learn from the Rabsaris, or chief of the eunuchs, being mentioned amongst the principal officers of Sennacherib.* In the sculptures eunuchs are represented as commanding in war;† fighting both in chariots and on horseback; and receiving the prisoners, and the heads of the slain after battle. They were also employed as scribes, and are seen writing down the number of the heads, and the amount of the spoil, obtained from the enemy. They were even accustomed to officiate in religious ceremonies. They appear, indeed, to have occupied the same important posts, and to have exercised the same influence in the Assyrian court, as they have since done in the East; where they have not only continually filled the highest offices of state, but have even attained to sovereign power.‡ It is to Assyria that tradition assigns the origin of the barbarous practice of mutilation, and it is upon a female that the odium of its introduction rests.§

The countenance of the eunuchs is strongly contrasted in

* 2 Kings, xviii. 17, and of Nebuchadnezzar, Jeremiah, xxxix. 3. In Daniel, i. 3, we have mention of the prince of the eunuchs. So many of the principal offices about the court were held by these persons, that their name came at last to be confounded with that of the great officers of state (compare 1 Samuel, viii. 15, 1 Kings, xxii. 9, and 2 Kings, xxiv. 12), and chamberlains and courtiers (2 Kings, ix. 32). Potiphar is called a "saris" or eunuch. That eunuchs were also an object of trade, and were brought, as at this day, from the centre of Africa, we learn from Jeremiah, xxxviii. 7.

† A eunuch set over the men of war is mentioned in 2 Kings, xxv. 19.

‡ As Agha Mohammed Khan of Persia.

§ Marcellinus, l. xiv. c. 6., and Claudian in Eutrop. l. i. v. 339, et seq.

"Seu prima Semiramis astu

Assyriis mentita virum, ne vocis acutæ
Mollities, levesve genæ se proderè possent,
Hos sibi conjunxit similes; seu Parthica ferro
Luxuries nasci vetuit lanuginis umbram;
Servatosque diu puerili flore, coegit
Arte retardatam Veneri servire juventam."

the sculptures with that of the man; and the rounded form, the bloated cheek, and double beardless chin, at once mark them, and distinguish them from females. Their dress consisted of a long tunic descending to the ankles, resembling the king's in shape, and in the richness and elegance of its embroideries. It was confined at the waist by a girdle edged with fringes; and a band, similarly adorned, passed over the shoulders. They wore no upper robe like that of the king. Their ear-rings, armlets, bracelets, and necklaces were similar in form to those of the monarch. In battle they were armed with the bow; and in peace, as well as in war, generally carried a sword and daggers. When represented as attending upon the king, they usually bear a quiver, bow, and mace; all probably for his use. At other times they raise a parasol or fan over his head, or present him with the sacred cup; on which occasion they are frequently unarmed.*

The umbrella or parasol, that emblem of royalty so universally adopted by Eastern nations, was generally carried over the king in time of peace, and sometimes even in war. In shape it resembled, very closely, those now in common use; but it is always seen open in the sculptures. It was edged with tassels, and was usually ornamented at the top by a flower or some other ornament. On the later bas-reliefs, a long piece of embroidered linen or silk, falling from one side like a curtain, appears to screen the king completely from the sun. The parasol was reserved exclusively for the monarch, and is never represented as borne over any other person.

The vizir or prime minister, the principal officers and attendants of the king, were clothed in robes resembling those of the eunuchs. They were armed with swords and daggers, and also wore necklaces, bracelets, and ear-rings. A fillet or band, either plain or richly ornamented, frequently confined their hair, and encircled their temples. The eunuch is occa-

* The cup-bearer appears to have been one of the principal officers in the Assyrian court. See 2 Kings, xviii, where the Rab-shakeh, or chief of the cup-bearers, is sent to induce the Jews to surrender.

sionally represented with this head-dress. The ends of this band were allowed to fall down the back.

The Assyrians paid particular attention to the adorning of their persons. Besides wearing the numerous ornaments described, they most carefully and elaborately platted their hair and beards. The hair was parted over the forehead, and fell from behind the ears on the shoulders, in a large bunch of ringlets. The beard was allowed to grow to its full length; and, descending low on the breast, was divided into two or three rows of curls. The mustache was also carefully trimmed, and curled at the ends. The hair, as well as the beard, appears to have been dyed, as is still the custom in Persia; but it has been doubted whether the hair, represented in the sculptures, was natural or artificial. The Egyptians were accustomed to wear large wigs, elaborately platted and adorned; and even false beards were not unknown. The Persians, also, at a later period, adopted this artificial coiffure;* but we have no evidence of its having been used in Assyria. On the contrary, according to Herodotus, the Babylonians wore their hair long.† The great regularity of the curls in the sculptures, would certainly lead to the impression that part of the hair, at least, was false; but we can scarcely suppose that the warriors, as well as the king, and all the principal officers of state, wore false beards; the sculptured beards being equally elaborate and studied in the arrangement. The treatment, however, of the hair in the bas-reliefs may be purely conventional. Most Eastern people have been celebrated for the length, and beauty of their hair; and if the Assyrians were as well provided with it, as the inhabitants of Persia were, in the days of Darius, or as they now are, they would have had little occasion for a wig.

The eyebrows were dyed black. Some substance resembling the kohl, or surma, used in the East to blacken the lids, and to give additional lustre to the eyes, was also employed; and we may conjecture that the complexion was improved

* Xenophon, lib. i. c. 3.

† Lib. i. c. 195.

and color added to the cheek, by paints and cosmetics. On the sculptures, traces of thick black and white pigments are always visible on the eyes, eyebrows, and hair; and these parts of the bas-reliefs appear to have been more carefully painted than any others.

Nicolaus of Damascus has preserved so faithful, and entertaining an account of the manners of the Babylonians, that I cannot resist the temptation of quoting it, as illustrative of the Assyrian sculptures in many respects. From whence this author obtained the following anecdote, it would now probably be impossible to ascertain; although it is evident, from its curious and accurate details, that it was borrowed from some ancient writer, who had himself witnessed the customs and fashions which he describes. The story is thus related:—"In the reign of Artæus, the king of the Medes, and one of the successors of Sardanapalus, the king of the Assyrians, there was amongst the Medes one Parsondes, a man renowned for his courage and strength, and greatly esteemed by the king on account of his good sense and the beauty of his person. He particularly excelled in the chase and in battle, whether he fought on foot, from his chariot, or on horseback. Now this Parsondes observed that Nanarus (the governor or tributary king) of Babylon, was very careful in his personal attire, and wore ear-rings, and shaved himself carefully, and was effeminate and unwarlike, and he disliked him exceedingly; so he asked Artæus, the king, to deprive Nanarus of his government, and to bestow it on himself. But Artæus, having bound himself by the compact entered into by Arbaces, was loth to act unjustly towards the Babylonian, and gave no answer to Parsondes. The matter, however, reached the ears of Nanarus, who promised great rewards to any one of his sutores who would catch his enemy.

"It happened one day that Parsondes, when hunting, went far from the king to a plain near Babylon. Sending his servants into a neighboring wood, that they might drive out, by their shoutings, the wild beasts, he remained outside to take

the game. Whilst chasing a wild ass he separated himself from his attendants, and came to a part of the Babylonian territories, where the sutlers were preparing markets for Nanarus. Being thirsty, he asked of them to drink; and they, delighted to have this opportunity of seizing him, gave him that which he required, took his horse, and bade him refresh himself. They then placed a sumptuous feast before him, served him with very sweet wine mixed with a certain intoxicating drug, and brought beautiful women to keep him company; so that, at length, overcome by the wine, he fell fast asleep. The sutlers then took him, and brought him bound to Nanarus.

“When Parsondes had recovered from the effects of the wine, Nanarus upbraided him for his conduct. ‘Why,’ said he, ‘did you, who have never suffered any wrong at my hands, call me a man-woman, (androgynæ,) and ask my government of Artæus, as if I were of no account, although of noble birth? Many thanks to him that he did not grant your request.’ Parsondes, nothing abashed, replied, ‘Because I thought myself more worthy of the honor; for I am more manly, and more useful to the king than you, who are shaven, and have your eyes underlined with stibium, and your face painted with white lead.’ ‘Are you not ashamed, then,’ said Nanarus, ‘being such as you describe yourself to be, to have been so overcome by your stomach and passions, that you should have fallen into the hands of one so greatly inferior to yourself? But I will quickly make you softer and fairer than any woman.’ And he swore by Belus and by Mylitta—for such is the name which the Babylonians give to their Venus; then beckoning to a eunuch, ‘Lead off,’ cried he, ‘this fellow. Shave, and rub with a pumice-stone, the whole of his body except his head. Bathe him twice a day, and anoint him: Let him underline his eyes, and plait his hair as women do. Let him learn to sing and to play on the harp, and to accompany it with his voice, that he may be amongst the female musicians, with whom he shall pass his time, having a smooth skin, and wearing the same garments as they do.’ The eunuch did as

he was commanded, and kept Parsondes in the shade, washing him twice every day, and polishing him with a pumice-stone, and making him pass his time in the same way as the women, so that he became very shortly fair, tender, and woman-like, singing and playing even better than any of the female musicians.

“The king, Artæus, having offered a reward, and searched in vain for his favorite, at last concluded that he had been devoured by wild beasts whilst hunting.

“Parsondes, having passed seven years in this mode of life at Babylon, induced a eunuch, who had been severely flogged and insultingly treated by Nanarus, to run away and inform Artæus of what had happened to him. Artæus immediately sent an envoy to demand the liberation of his former favorite. But Nanarus, frightened, declared that he had never seen Parsondes since he had disappeared. Artæus, however, sent a second ambassador, much greater in rank and more powerful than the previous one, and threatened, by letter, to put to death the Babylonian, unless he delivered up his captive. Nanarus, being now greatly alarmed, promised to give up the man, and moreover apologized to the ambassador, declaring, that he was sure the king would see that he had justly treated one, who had endeavored to ruin him in the king’s favor. He then entertained the ambassador with a great feast, during which entered, to the number of one hundred and fifty, the female players, amongst whom was Parsondes. Some sang, and others played on the flute; but the Mede excelled them all both in skill and beauty, so that when the feast was over, and Nanarus asked the ambassador which of the women he thought superior to the rest in beauty and accomplishments, he pointed without hesitation to Parsondes. Nanarus, clapping his hands, laughed a long time, and then said, ‘Do you wish to take her with you?’ ‘Certainly,’ replied the ambassador. ‘But I will not give her to you,’ said Nanarus. ‘Why, then, did you ask me?’ exclaimed the other. ‘This,’ said Nanarus, after a little hesitation, ‘is Parsondes, for whom you have come.’ And the

ambassador disbelieving him, he swore to the truth of what he had said.

“On the following day the Babylonian placed Parsondes in a wagon, and sent him away with the ambassador to Artæus, who was at Susa. But the king did not recognize him, and was a long time before he would believe that so valiant a man could become a woman.

“Parsondes exacted a promise from Artæus, that he would revenge him upon Nanarus. And when the king came to Babylon, he gave Nanarus ten days to do what was right; but the Babylonian, alarmed, fled to Mitraphernes, the chief of the eunuchs, and promised him for himself ten talents of gold, and ten gold cups, and two hundred of silver, and one hundred talents of silver money, and several suits of clothes; and for the king, one hundred talents of gold, and a hundred gold cups, and three hundred of silver, and one thousand talents of silver money, and numerous dresses and other fine gifts, if he would save his life and keep him in the government of Babylon. The eunuch, who was held in great estimation by the king, succeeded; but Parsondes waited his opportunity, and afterwards, finding an occasion, took his revenge both on Nanarus and the eunuch.”*

There are many customs mentioned in this narrative, which, it is evident, from the sculptures of Nimroud, existed amongst the Assyrians, such as those of painting the eyes and face, and plating the hair. The anecdote, too, is quite in accordance with Eastern manners; and if there be any truth in it, we may conclude that, in their mode of transacting public business, as

* Fragments of Nicolaus of Damascus, in the *Prodromos Hellenikes Bibliothekes*, 8vo. Paris, 1805, p. 229. I am indebted to Mr. Birch for this free version of the anecdote. That the effeminate customs described by Nicolaus existed amongst the kings and nobles of the Assyrian empire, is confirmed by all the ancient historians. Sardanapalus, according to Athenæus, when first seen by Arbaces, was adorned and dressed like a woman, his chin was shaved, and his skin was rubbed smooth with the pumice-stone. His flesh was as white as milk, and his eyes and eyebrows were painted black. (Athen. lib. xii.) Astyages, too, according to Xenophon (*Cyrop. lib. i. c. 3*), had his eyes and face painted, and wore false hair.

well as in their domestic life, the Assyrians did not differ greatly from the Persians and Turks of modern times. We have the eunuch holding the highest offices of the state, and possessing great influence over the monarch. Through him political intrigues were carried on, and he was as disposed to accept a bribe, both on his own account and on that of his master, as those who still hold the same position in Eastern courts. It was through the influence of the chief eunuch, that Arbaces succeeded in seeing Sardanapalus, and being a witness to that effeminacy of dress and manner, which encouraged the Mede to rebel against the Assyrians.*

When in the presence of the king, the eunuch and principal officers of state, were in the highest degree respectful in their demeanor. They stood before him with their hands crossed in front—an attitude still assumed in the East, by an inferior in the presence of his master. It is interesting thus to trace the observance of the same customs, during so many centuries.† The vizir is also frequently represented elevating his right hand—an action apparently denoting an oath or homage. Dependents are seen in the same posture, on monuments of the Achæmenian and Sassanian dynasties.

We know from the story of Esther, how sacred the person of the king was considered, it being death for even the queen to venture before him unbidden.‡ Deioces permitted no one to see him, except privileged persons; and it was unlawful for any one to laugh or spit in his presence.§

The costume of the warriors differed according to their rank and the nature of the service they had to perform.||

* Athenæus, lib. xii.

† We find (Tobit i. 22) that, even in the days of Esarhaddon, a Jew was the principal banker, steward, and keeper of the accounts of the palace; as he is still in the East, where not outwitted by the Armenian.

‡ Esther, iv. 11.

§ Herod. lib. i. ch. 99. So the passage must be understood, for it says that no man was admitted into the king's presence; and yet he was consulted through messengers, who, we must presume, were forbidden to laugh and spit before him.

|| Jeremiah describes the dresses of the warriors. "Order ye the buckler and

Those who fought in chariots, and held the shield for the defence of the king, are generally seen in coats of scale armor, which descend either to the knees or to the ankles. A large number of scales were discovered in the earliest palace of Nimroud.* They were generally of iron, slightly embossed or raised in the centre; and some were inlaid with copper. They were probably fastened to a shirt or felt, of coarse linen.† Such is the armor always represented in the most ancient sculptures. At a later period other kinds were used; the scales were larger, and appear to have been fastened to bands of iron or copper. The armor was frequently embossed with groups of figures, and fanciful ornaments; but there is no reason to believe, that the rich designs on the breasts of the kings were on metal.‡

The warriors were frequently dressed in an embroidered tunic, which was probably made of felt or leather, sufficiently thick to resist the weapons then in use. On the sculptures of Kouyunjik they are generally seen in this attire. Their arms were bare from above the elbow, and their legs from the knees downwards, except when they wore shirts of mail which descended to the ankles. They had sandals on their feet. The warriors on the later Assyrian monuments, particularly on those of Khorsabad, are distinguished by a peculiar ornament, somewhat resembling the Highland phillibeg. It appears to be fastened to the girdle, and falls below a short tunic.

shield, and draw near to battle. Harness the horses; and get up, ye horsemen, and stand forth with your helmets; furbish the spears, and put on the brigandines (or coats of mail)." (Ch. xlvi. ver. 3, 4.)

* In chamber I, plan 3, where also the helmets and various other iron and copper fragments were found. Some interesting scale armor, inscribed with the name of Shishak I., is in the collection of Dr. Abbot at Cairo. (Prisse Monum.)

† The plates of steel, resembling the scales of fishes, are described by Herodotus as worn by the Persian warriors. (Lib. vii. c. 61.)

‡ They may have been the "linen cuirasses" mentioned by Herodotus (lib. vii. c. 63) as worn by the Assyrians in the army of Xerxes. M. Lajard has published in his work on the worship of Mithra (plate 47) a piece of armor similar in shape to that found at Nimroud, and which has every appearance of being Assyrian. It is embossed with groups of figures and Assyrian symbols.

TIME YORK
AND
IONS.



A SPEARMAN. (Kouyunjik.) Page 261.



AN ARCHER. (Kouyunjik.) Page 261.



A SLINGER. (Kouyunjik.) Page 265.



Assyrian Warriors fighting with the Enemy. An Eagle is carrying away the Entrails of the Slain. (Centre Palace, Nimroud.) Page 264.

Assyrian Warrior with Spear and Shield. (Kouyunjik.) Page 265.



MANACLES FOR THE HAND. (Khorsabad and Kouyunjik.) Page 288.



MANACLES FOR THE FEET. (Khorsabad and Kouyunjik.) Page 288.

In the sculptures of Kouyunjik and of monuments of the same period, the dress of the soldiers appears to vary, according to the manner in which they are armed. Those with spear and shield wear pointed or crested helmets, and plain or embroidered tunics, confined at the waist by a broad girdle. A kind of cross-belt passes over the shoulders, and is ornamented in the centre of the breast by a circular disk, probably of metal. The slingers are attired in the embroidered tunic, which I conjecture to be of felt or leather; and wear a pointed helmet, with metal lappets falling over the ears. Both the spearmen and slingers have greaves, which appear to have been laced in front.*

The archers are dressed in very short embroidered tunics, which scarcely cover half the thigh, the rest of the leg being left completely bare. They are chiefly distinguished from other warriors by the absence of the helmet. A simple band round the temples confines the hair, which is drawn up in a bunch behind.

It is probable that these various costumes indicate people of different countries, auxiliaries in the Assyrian armies, who used the weapons most familiar to them, and formed different corps or divisions.† Thus in the army of Xerxes, were marshalled men of many nations; each armed according to the fashion of his country, and fighting in his own peculiar way. We may, perhaps, trace in the Assyrian sculptures, several of the costumes described by the Greek historian, as worn by those who formed the vast army of the Persian king.

In the shape of their helmets the Assyrians displayed con-

* They were perhaps of leather, or, like the boots of the Bœotians, of wood, or even of brass, as the greaves of Goliath. (1 Samuel, xvii. 6) The whole of the giant's armor, his helmet, his coat of mail, and his shield, were of the same metal.

† According to Diodorus Siculus (l. ii.) it was customary for the nations tributary to the Assyrians to send, yearly, bodies of troops to serve either in war, or as garrisons. They were encamped outside the gates of Nineveh. The Assyrian king had thus, always a considerable standing army at his disposal.

siderable taste. We trace in them, indeed, many well-known forms afterwards adopted by the Greeks.*

The pointed helmet in the bas-reliefs, from the earliest palace of Nimroud, appears to have been the most ancient, and in the most general use; it is, indeed, characteristic of the Assyrian warrior. Several were discovered in the ruins: they were of iron; and the rings which ornament the lower part, and end in a semicircle in front, were inlaid with copper.†

These pointed helmets were sometimes furnished with lappets or flaps covered with metal scales, concealing the ears, the back of the head, the chin, and the neck, and falling over the shoulders; the whole head-dress having then very much the appearance of the early Norman casque. At a later period, a metal lappet merely protected the ears and side of the face, and was attached to the outer rim of the helmet.

Circular iron caps, fitting closely to the head, were also in use at an early period. The horseman who leads the horse of the warrior, in a bas-relief from the most ancient palace at Nimroud, is represented with this head-dress; and in a sculpture from the centre ruins, it is worn by archers.

The helmets of the later monuments of Nimroud, and of those of Khorsabad and Kouyunjik, are frequently surmounted by a curved crest, or by a kind of plume. They show considerable variety, and even elegance, in their forms. The simple curved crest, resembling that of the Greek helmet, appears, from the sculptures, to have been peculiar to some nation conquered by the Assyrians; but fragments of helmets of this shape were found, in the excavations, in the same chamber as the pointed casques.

The conical helmet of the Assyrians, appears to have been

* The invention of the crested helmet, as well as of the ornamented shield, is attributed by Herodotus (lib. i. c. 171) to the Carians, but it is more probable that they received both indirectly from the Assyrians.

† Herodotus says that the Assyrian helmets were of brass. *Loc. cit.*

worn even to the latest period. It has been conjectured that this head-dress connects them with the Scythians, who, according to Herodotus, had high-pointed caps.* In the rock, sculptures of Bisutun, the Scythian prisoner is represented with a lofty conical head-dress; which differs, however, in shape from the Assyrian helmet. It is slightly curved at the top, and was probably, therefore, made of felt, or some pliable material, and not of metal; and this may also be inferred from the expression of Herodotus, "that the caps, *although* coming to a point, stood erect."

The arms of the early Assyrians were the spear, the bow, the sword, and the dagger.† The sling is not represented in the most ancient monuments as an Assyrian weapon, although used by a conquered nation; it was, perhaps, introduced at a later period. The bows were of two kinds: one long and slightly curved, the other short and almost angular: the two appear to have been carried at the same time, by those who fought in chariots.

The arrows were probably made of reeds, and were kept in a quiver slung over the back. The king, however, and the great officers of state, were followed by attendants, who carried the quivers, and supplied their masters with arrows. The bow was drawn to the cheek, or to the ear, as by the Saxons, and not to the breast, after the fashion of the Greeks. The barbs were of iron and copper, several of both materials having been found in the ruins. When in battle, it was customary for the archer to hold two arrows in reserve in his right hand; they were placed between the fingers, and did not interfere with the motion of the arm, whilst drawing the bow. When marching he usually carried the larger bow over his shoulders, having first passed his head through it. The bow

* The Saccæ, who are a Scythian nation, had caps which terminated in a point, and wore loose trousers. (Lib. vii. c. 64.) The latter article of dress is certainly not represented in the Assyrian sculptures

† The Assyrians in the army of Xerxes carried shields, spears, daggers, and wooden clubs knotted with iron. (Herod. *loc. cit.*)

of the king was borne by an attendant. The smaller bows were frequently placed in the quiver, particularly by those who fought in chariots. A leather or linen guard was fastened by straps to the inside of the left arm, to protect it when the arrow was discharged. The swords were worn on the left side, and suspended by belts passing over the shoulders, or round the middle; some were short and others long. I have already alluded to the beauty of the ornaments on the hilt and sheath.

The dagger appears to have been carried by all, both in time of peace and war; even the priests and divinities are represented with them.* They were worn indifferently on the left and right side, or perhaps on both at the same time. Generally two, or sometimes three, were inserted into one sheath, which was passed through the girdle. The handles, as I have already mentioned, were most elaborately adorned, and were frequently in the shape of the head of a ram, bull, or horse, being made of ivory or rare stones.† A small chain was sometimes fastened to the hilt, or to the sheath, probably to retain it in its place. A dagger, resembling in form those of the sculptures, was found amongst the ruins of Nimroud: it is of copper. The handle is hollowed, either to receive precious stones, ivory, or enamel.

The spear of the Assyrian footman was short, scarcely exceeding the height of a man; that of the horseman appears to have been considerably longer. The iron head of a spear from Nimroud, has been placed in the British Museum. The shaft was probably of some strong wood; and did not consist

* This is still the custom in Persia. In that country no dress, except that of persons specially devoted to religious duties, is complete without a dagger with a jewelled or ivory handle. The dagger was probably used by the Assyrians not only as a weapon, but, like the *μαχαίρα* of the Greeks, for carving the dinner. Cf. Ælian, ii. 17, for the story of Ochus, who was watched by the magi, when he ate his first dinner, and his cutting a loaf and laying a slice of meat on it.

† Several dagger-handles of ivory, carved in the shape of the fore-part of bulls, and other animals, were found in the tomb of an ivory-worker at Memphis.

of a reed, like that of the modern Arab lance. The large club pointed with iron, mentioned by Herodotus amongst the weapons carried by the Assyrians, is not represented in the sculptures; unless, indeed, the description of the historian applies to the mace, a weapon in very general use amongst them, and frequently seen in the bas-reliefs. This weapon consisted of a short handle, probably of wood, to which was fixed a head, evidently of metal, in the shape of a flower, rosette, lion, or bull. To the end of the handle was attached a thong, apparently of leather, through which the hand was passed. I have not found any representation of warriors using the hatchet, except when cutting down trees, to clear the country preparatory to a siege. It is, however, generally seen amongst the weapons of those who fought in chariots, and was carried in the quiver, with the arrows and short angular bow.*

In the bas-reliefs of Kouyunjik, slingers are frequently represented amongst the Assyrian troops. The sling appears to have consisted of a doubled rope, with a thong, probably of leather, to receive the stone; it was swung round the head. The slinger held a second stone in his left hand, and at his feet is generally seen a heap of pebbles ready for use.†

The javelin is frequently included amongst the weapons of the Assyrian charioteers; but the warriors are not represented as using it in battle. It was carried in the quiver amongst the arrows.

The shields of the Assyrians were of various forms and materials. In the more ancient bas-reliefs a circular buckler, either of hide or metal, perhaps in some instances of gold and silver,‡ is most frequently introduced. It was held by a handle

* See woodcut facing page 269.

† That the Persian slingers were exceedingly expert, used very large stones, and could annoy their enemies whilst out of the reach of their darts or arrows, we learn from several passages in Xenophon. (See particularly *Anabasis*, lib. iii. c. 3.)

‡ King Solomon made three hundred shields of beaten gold; three pounds of gold to each shield. (1 Kings, x. 17.) The servants of Hadadzer, king of Zo-

fixed to the centre. Light oblong shields of wicker-work, carried in a similar manner, are also found in the early sculptures; but those of a circular form appear to have been generally used by the charioteers.

Suspended to the backs of the chariots, and carried by warriors, are frequently seen shields in the shape of a crescent, narrow, and curved outwards at the extremities. The face is ornamented by a row of angular bosses, or teeth, in the centre of which is the head of a lion.

In the sculptures of Khorsabad, the round shield is often highly ornamented. It resembles, both in shape and in the devices upon it, the bucklers now carried by the Kurds and Arabs, which are made of the hide of the hippopotamus. In the bas-reliefs of Kouyunjik, some warriors bear oval shields, very convex, and sufficiently large to cover the greater part of the body. The centre and outer rim were decorated with bosses.

The shield used in a siege concealed the whole person of the warrior, and completely defended him from the arrows of the enemy. It was made either of wicker-work, or of hides. It was furnished at the top with a curved point, or a square projection, like a roof, at right angles to the body of the shield; which may have served to defend the heads of the combatants against missiles, discharged from the walls and towers of a castle. Such were probably the shields used by the Persian archers at the battle of Plataea.*

The archers, whether on foot or in chariots, were accompanied by shield-bearers, whose office it was to protect them from the shafts of the enemy. Sometimes one shield covered

bah, carried shields of gold. (2 Samuel, viii. 7.) The shield of Goliath was of brass.

* Herod. lib. ix. c. 61. The expression of the Greek historian, that the Persians made a fence of their osier shields, has perplexed the commentators, who conjecture that the archers formed a rampart of bucklers, from behind which they discharged their arrows. But the sculptures of Nimroud, and Kouyunjik, completely illustrate the passage; a shield covering the whole person being held by a second warrior. The shields of the Persians were of osier covered with skins.

two archers. The shield-bearer was usually provided with a sword, which he held ready drawn for defence. The king was always attended in his wars by this officer; and even in peace, one of his eunuchs usually carried a circular shield for his use.* This shield-bearer was probably a person of rank, as in Egypt. On some monuments of the later Assyrian period, he is represented carrying two shields, one in each hand.

Some of the circular bucklers appear to have been made of small pieces of wood or leather, carefully united. The handles attached to the small circular shields may have been of leather; but those belonging to the larger, which were supported entirely by them, must have been of wood or metal.†

Standards were carried by the charioteers. In the sculptures they have only two devices; one a figure (probably that of the divinity) standing on a bull and drawing a bow; the other, two bulls running in opposite directions.‡ These figures are inclosed in a circle, and fixed to the end of a long staff, ornamented with streamers and tassels. The standards seem to have been partly supported by a rest in front of the chariot, and a long rod or rope connected them with the extremity of

* Teucer, when discharging his arrows against Hector, was protected by the shield of Ajax.

“ And last, young Teucer with his bended bow—
Secure behind the Telamonian shield,
The skilful archer wide surveyed the field.”

Iliad, b. viii. l. 319.

And again:

“ Thus Ajax guards his brother in the field,
Moves as he moves, and turns the shining shield.” . l. 327.

Goliath had one “bearing his shield, who went before him.” (1 Samuel, xvii. 7.)

† According to Herodotus (lib. i. c. 171) the Carians invented the handle of the shield; held before their time by a thong of leather suspended from the neck. The bucklers used during the Trojan war had wooden handles. (*Iliad*, viii. 193.)

‡ Mr. Birch suggests that these may resemble the symbols of war and peace, which were attached to the yoke of Darius's chariot.

the pole. In a bas-relief from Khorsabad, this rod is attached to the top of the standard.*

The Assyrians, like the Egyptians, appear to have had organized and disciplined troops. In the sculptures of Kouyunjik, we not only find long lines of warriors on foot, divided into companies, each distinguished by their dress or their arms; but also horsemen and chariots marshalled in array.† In one chamber of these ruins, the walls were covered with small figures of armed men, marching in file. In the same edifice were representations of archers defended by shields, and drawn up in line before the walls of a besieged city. In front of them were rows of spearmen, the first rank kneeling, and the second stooping, to enable the archers behind to discharge their arrows. The group thus formed bears some resemblance to the phalanx of the Greeks, and to the squares of modern infantry.

A great part of the strength of the Assyrian armies consisted in chariots and horsemen, to which we have frequent allusion in the inspired writings.‡ The chariots appear to have been used by the king, and the highest officers of state,

* Standards, somewhat similar to those represented in the Assyrian bas-reliefs, were in use in Egypt. Some sacred animal, or emblem, was also generally placed upon them. Standards, and banners, are mentioned on several occasions in the Bible. (Jer. iv. 21; Song of Solomon, vi. 4.)

† Uziah "had a host of fighting men, who went out to war by bands." [2 Chron. xxvi. 11.] Josephus (l. ix. c. 10) describes how these men were divided into companies, and were armed, each man with a sword, shield, breast-plate of brass, bow and sling; the weapons carried by the warriors of the Assyrian sculptures.

‡ The chariots and horses of Naharaina (Mesopotamia) are mentioned in an Egyptian monument of the earliest kings of the 18th dynasty: an officer of Thothmes I. "captured for him, in the land of Naharaina, twenty-one hands, a horse, and a chariot." (Birch's Memoir on the Statistical Tablet of Karnak, p. 8.) The Elamites, amongst the tributaries of the Assyrians, were celebrated for their chariots carrying archers. (Isaiah, xxii. 6.) Chariot cities, or cities for the support of warriors fighting in chariots, are frequently mentioned in the Bible. (2 Chron. i. 14, and viii. 6.) Solomon had 1400 chariots, the Syrians 700 (2 Samuel, x. 18), the Philistines 30,000 (1 Samuel, xiii. 5).

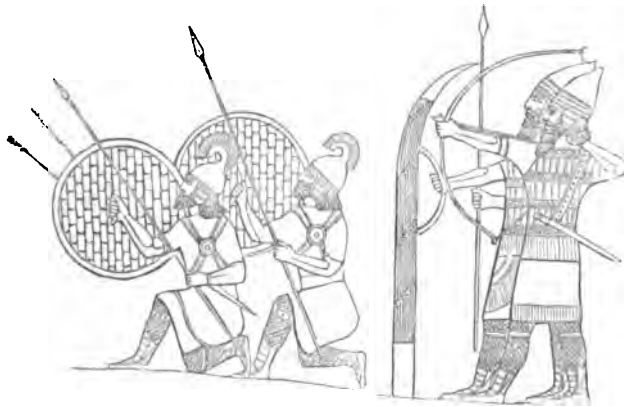

WARRIORS FORMING A PHALANX BEFORE THE WALLS OF A BESIEGED CITY.
(Kouyunjik) Page 268.



GROOM LEADING HORSES.* (From a Fragment discovered at Khorsabad,
and now in the British Museum.) Page 272.

* It must be remarked that these horses may belong, not to the Assyrians, but to a conquered nation. Mr. Birch observes that the people leading them have the same head-dress and garments as the Ruten of a tomb at Thebes.

NEW YORK
MAY 1911

THE NEW YORK
PUBLIC LIBRARY
ASTOR LENOX AND
TILDEN FOUNDATIONS.

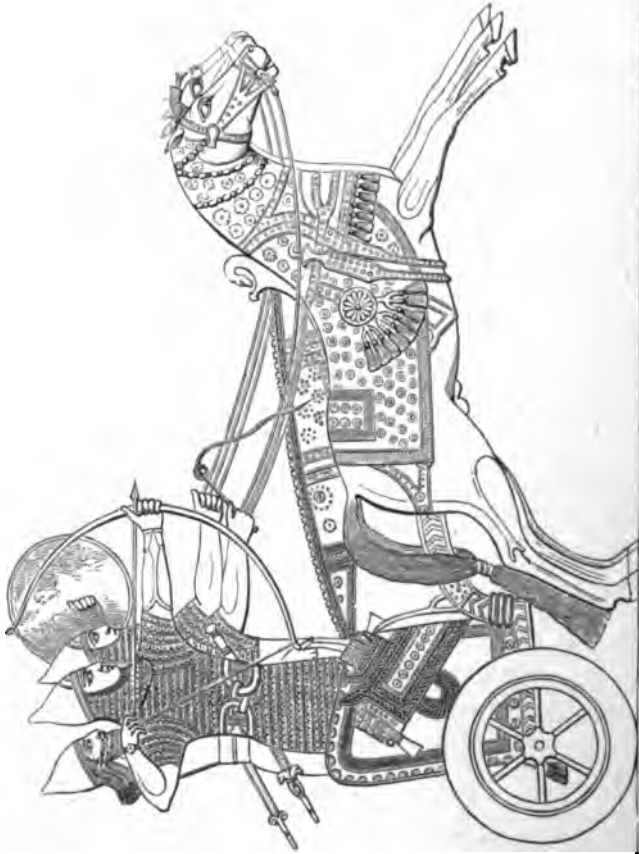

ASSYRIAN WARRIORS IN A CHARIOT. (S. W. Ruins Nimroud, but originally brought from the N. W. Palace.)

who are never seen in battle on horseback; or, except in sieges, on foot.* They contained, either two, or three persons. The king was always accompanied by two attendants—the warrior protecting him with a shield (who was replaced during peace, by the eunuch bearing the parasol), and the charioteer. The principal warriors were also frequently attended by their shield-bearer, though sometimes the driver alone is with them.

The chariot was used during a siege, as well as in open battle. The king and his warriors are frequently represented, as fighting with the enemy beneath the walls of a castle; or as having dismounted from their cars, to discharge their arrows against the besieged. In the latter case, grooms on foot held the horses. When the king in his chariot formed part of a triumphal procession, armed men led the horses. The chariot was also preceded, and followed by men on foot.

The Assyrian chariot was probably made of wood.† It appears to have been open behind; but, unlike those commonly used by the Egyptians, to have been completely panelled at the sides. It varied considerably in form, at different periods. As represented on the earliest monuments, it is low with the upper part rounded. To each side were fixed, as in Egypt, two quivers, containing arrows, a small crooked bow, a javelin, and a hatchet or battle-axe. The pole was sustained by a forked rod, fastened to the forepart of the chariot, which was also connected with the end of the pole by a singular contrivance. Neither the use, nor the material of this part of the chariot, can be determined from the sculptures. Its size precludes the idea of metal, or even of solid wood; and I can only conjecture that it was a light wooden framework, covered with linen

* Amongst the ancient Indians the king, and men of rank generally, combated in chariots; very rarely, and only at a later period, on horseback. In the Assyrian sculptures, only war-chariots have hitherto been discovered; we have no representation of the magnificent carriages which, under the name of *armamaxæ*, were used by the ancient Persians in processions, and for their women.

† Chariots of iron are mentioned in Judges (i 19 and iv. 3). The car from the Egyptian tomb, now at Florence, was made of birchwood and ivory.

or silk, and intended as an ornament. It was elaborately painted or embroidered, and was generally divided into three compartments containing sacred emblems—such as the sun, moon, seven stars, and the horned cap. Although the yoke was for two horses, three were generally harnessed to the chariot.* There is no indication of traces, nor can it be ascertained from the sculptures how the third horse was attached. It was probably intended to supply the place of a killed horse, and did not draw.† In a bas-relief representing the passage of a river, a chariot is seen in a boat, and consequently without the horses. We can thus judge of the form of the pole and yoke, but not of the precise mode of their use, nor of the material of which they were made.

The wheels had six spokes, and the felloes consisted of four pieces. They appear to have been thicker and more solid, and the whole chariot, indeed, to have been heavier than that of the Egyptians. At the end of the pole, which was curved outwards, was generally the head of a bull, ram, or some other animal, probably, as among the Greeks, in metal. Sometimes a semicircular metal plate or crest, ornamented with the figure of the winged bull, or with some other religious emblem, was attached to the end of the pole, and rose above the backs of the horses.

Behind the chariot was suspended a shield, with teeth or bosses like that described; and a spear was placed upright in a rest, which was usually in the shape of a human head.

The warriors stood upright in the chariot, which does not seem to have been furnished with seats.

At a later period the Assyrian chariot‡ appears to have undergone a considerable change, both in form and size. The large ornamented framework, stretching from the forepart to

* In this respect the most ancient Assyrian chariot differed from the Egyptian, to which only two horses were harnessed.

† As amongst the Greeks in the time of Homer. This third horse was called *trapepos*.

‡ See woodcut opposite page 111.

the end of the pole, was replaced by a thin rod, or by a rope or leather thong, knotted in the centre or near the end. The horses were also differently harnessed. The pole terminated no longer in the head of an animal, and the yoke, as far as we can judge by the sculptures, was altogether of another shape. The later Assyrian chariot, moreover, like the Egyptian and Persian, was always drawn by two horses, not by three.* It was also much higher, and larger, than that of the ancient sculptures, the wheel alone being almost of the height of a man. The upper part was not rounded, but square, with a projection in front, which may have been a case to receive arrows; as quivers were not attached to the sides as represented in the oldest Nimroud bas-reliefs. The panels of the chariot were carved, and adorned with rosettes and tassels. The wheel had eight, and not six spokes; and was apparently strengthened by four pieces of metal, which bound the felloes. The whole chariot closely resembled that of the Persepolitan sculptures, and of the great Mosaic from Pompeii in the Museum of Naples, the subject of which is conjectured to be one of the battles between Alexander and Darius.

The later chariots were often completely covered with ornaments; those represented on the earlier monuments had a very elegant moulding, or border, round the sides. They were probably inlaid with gold, silver, and precious woods, and also painted.† In a bas-relief at Khorsabad, a figure of the king drawing a bow was placed as a device on a chariot panel.

Chariots armed with scythes are not seen in the Assyrian

* From a passage in Zechariah (vi. 2) it would appear that the chariot-horses were sometimes paired according to their colors. The chariot of Darius on the cylinders, and on the silver daric, as well as in the Persepolitan sculptures, is drawn by two horses.

† Such were the chariots obtained by the Egyptians from Naharina (Mesopotamia), fifteen centuries before Christ. In the Statistical Tablet of Karnak are mentioned "thirty chariots worked with gold and silver, with painted poles," as brought from that country, and chariots similarly adorned with paintings from the Ruten-nu, a neighboring people.

sculptures, although mentioned by Ctesias as being in the army of Ninus.

As chariots were in such general use, we may presume that the Assyrians had formed roads, not only over the plains, but through the mountainous provinces of their dominions. Indeed, in the sculptures of Kouyunjik, both chariots and horsemen are seen crossing high mountains.

The harness and trappings of the horses were extremely rich and elegant. Plumes waved over their heads, or fanciful crests rose gracefully in an arch above the ears, and descended in front to the nostrils. To these ornaments were sometimes appended long ribands or streamers, which floated on the wind. Large tassels of wool or silk, dyed many colors, fell on the forehead, and were attached to many parts of the harness. The bridle generally consisted of a head-stall, a strap divided into three parts connected with the bit, and straps over the forehead, under the cheeks, and behind the ears. All these details were elaborately ornamented. In the earlier sculptures we find the figures of winged bulls, and other symbolical devices, on parts of the head-furniture; in the latter, rosettes are more commonly introduced, frequently producing a very pleasing appearance.

It is probable that the bit, as well as many ornaments of the bridle and trappings, were of gold and other precious materials.*

The bit of the earlier Assyrians was in the form of a double wedge or dovetail, and appears to have acted more like a curb than a snaffle. The rein was attached to the centre, and the bit probably worked as a lever. At a later period the form of the bit was altered, and the rein was fastened nearer the end, to add to its power.

Round the necks of the horses were hung tassels, rosettes,

* The horses ridden by Astyages and Cyrus had bridles of gold. Xenoph. Cyrop. lib. i. c. 3. Compare 1 Esdras, iii. 6, where the chariots with bridles of gold of the Persians are mentioned.

1912



Source: *Le Monde Illustré*, 1881, New York

Fig. 2. ASSYRIAN CHARIOT OF THE LATER PERIOD. (SW. RUIN, NIMROUD.)

Published by George F. Putnam, New York

Fig. 2

and engraved beads. Three straps, richly embroidered, passing under the forepart of the belly, kept the harness and chariot-pole in their places. A breast-band, adorned with tassels, was also supported by these straps. To the yoke was suspended a very elegant ornament, formed by the head of an animal, and a circle, in which was sometimes introduced a winged bull, a star, or some other sacred device. It fell on the shoulder of the animal, and to it were attached three clusters of tassels.

Embroidered clothes, or trappings, were frequently thrown over the backs of the chariot-horses, and almost covered the body,* from the ears to the tail. They were kept in their place by straps passing round the breast, the rump, and the belly.

The chariot-horses of the later Assyrian period differed entirely in their trappings and harness from those of the earlier. High plumes, generally three in number, and rising one above the other, waved over their heads. Frequently an arched crest, and clusters of tassels, were placed between their ears. Similar tassels fell over their foreheads, and hung round their necks. The harness attached to the yoke, was more profusely ornamented with rosettes and fringes, than that of the earlier Assyrian chariots; but the ornaments showed less variety and taste.

The manes were either allowed to fall loosely on the neck, were platted, or were cut short and stood erect. In the earlier sculptures, the tails of the horses are simply bound in the centre with ribands; in the later, the end is platted, as is now the fashion in Persia and Turkey, and tied up in a bunch.†

Each horse appears to have been guided by two reins, and the charioteer held three in each hand when driving three

* "Dedan was thy merchant in precious clothes for chariots." (Ezekiel, xxvii. 20.)

† This later fashion appears to have been adopted by the Persians, and is represented in the Persepolitan sculptures. (Sir R. Kerr Porter, Pl. 41, 48, 49 and 50.) Compare also the chariot and horses on the darics, and on the early tombs from Xanthos.

horses. He also carried a whip, which, like the Egyptian, consisted of a simple thong, attached to a loop at the end of a short handle. In the later Assyrian sculptures this thong is frequently divided into two or three lashes, the handle of the whip terminating in the head of a bull or lion.

The horsemen formed a no less important part of the Assyrian army than the charioteers.* Horsemen are seen in the most ancient sculptures of Nimroud;† and I have already mentioned, that disciplined bodies of cavalry were represented in the bas-reliefs of Kouyunjik. We learn from the book of Judith that Holofernes had 12,000 archers on horseback.‡ The king himself is never represented on horseback, although a horse richly caparisoned, apparently for his use—perhaps to enable him to fly, should his chariot-horses be killed—is frequently seen led by a warrior and following his chariot.

In the earliest sculptures the horses, except such as are led behind the king's chariot, are unprovided with clothes or saddles. The rider is seated on the naked back of the animal. At a later period, however, a kind of pad appears to have been introduced; and in a sculpture at Kouyunjik was represented a high saddle not unlike that now in use in the East.

The horsemen were armed with bows, or with long spears.§ They wore short tunics and their legs and feet were bare. When riding without pads or saddles, they sat with their knees almost on a level with the horse's back. After the introduction of saddles, their limbs appear to have been more free, and

* "Assyrians clothed in blue, captains and rulers, all of them desirable young men, horsemen riding upon horses." (Ezekiel, xxiii. 6.)

† It is singular, as observes Sir Gardner Wilkinson (*Ancient Egyptians*, vol. i. p. 288), that horsemen are nowhere represented on the monuments of Egypt, although there can be no doubt, from numerous passages in the sacred writings, that cavalry formed an important part of the Egyptian armies.

‡ Judith, ii. 15. Solomon had 12,000 horsemen. (1 Kings, x. 26.)

§ "The horsemen lifteth up both the bright sword and glittering spear." (*Nahum*, iii. 3.)



HORSEMEN—ONE DRAWING THE BOW, THE OTHER HOLDING THE REINS OF BOTH HORSES. (N. W. Palace, Nimroud.) page 274.

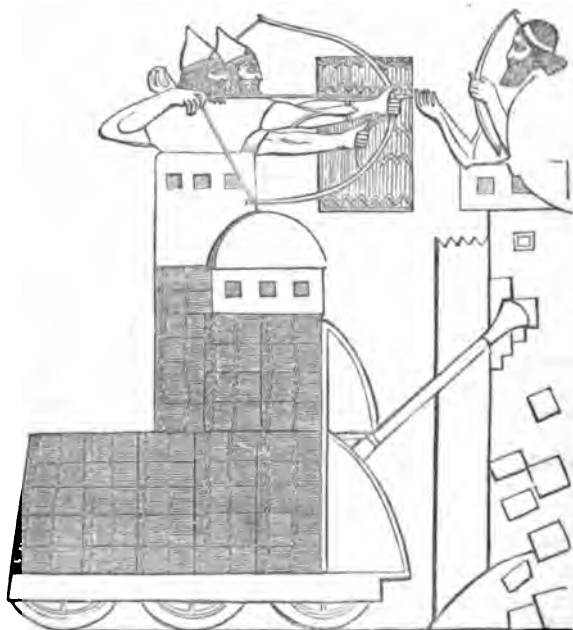

Battering-Ram, with moveable Tower containing Warriors. (N. W. Palace, Nimroud.) Page 282.

they wore greaves or boots, but were unprovided with stirrups.

When an archer on horseback was in battle, his horse was held and guided by a second horseman, who rode by his side. He was then able to discharge his arrows freely. On the monuments of Khorsabad and Kouyunjik, the cavalry are usually armed with the spear. When using this weapon they did not require a second horseman to hold the reins.

The riding-horses are less richly and profusely adorned than those in harness, the horsemen being probably of inferior rank to those who fought in chariots. The head-stall was surmounted by an arched crest, and round the neck was an embroidered collar, ending in a rich tassel or bell.*



Head-dress of a Riding-Horse (Kouyunjik).

The horses of the Assyrians, so far as we can judge from the sculptures, were well formed and apparently of noble blood. It has been doubted whether the breed for which Mesopotamia and the neighboring deserts of Arabia are now celebrated, existed in the same vast plains at a remote period; or whether it was introduced shortly before the Mohammedan conquest.

* See woodcut, p. 29, where a bell appears to be suspended round the neck of a horse. Bells for horses' necks are mentioned in Zechariah, xiv. 20.

Although we have no mention in the sacred writings of a trade actually carried on in horses with Assyria, as with Egypt, yet it may be inferred from several passages that it did exist.* Horses, it will be remembered, were offered to the Jews, by the general of the Assyrian king, as an acceptable present;† and in the statistical tablet of Karnak, they are mentioned amongst the objects of tribute brought by the people of Naharaina (Mesopotamia) and the neighboring countries to the Egyptians. We may judge, therefore, that the Assyrian horses were celebrated at a very early period. The Egyptians, indeed, appear to have been chiefly indebted to the countries watered by the Tigris and Euphrates for their horses, no representation of this animal occurring, I believe, on Egyptian monuments earlier than the eighteenth dynasty.‡ However that may be, no one can look at the horses of the early Assyrian sculptures without being convinced that they were drawn from the finest models.§ The head is small and well-shaped, the nostrils large and high, the neck arched, the body long, and the legs slender and sinewy. "Their horses are swifter than the leopards, and more fierce than the evening wolves," exclaims the prophet, of the horses of the Chaldæans.|| That the Assyrians faithfully portrayed animals, is shown by the lions,

* 1 Kings, x. 28, 29.

† 2 Kings, xviii. 23. "Now therefore, I pray thee, give pledges to my lord the king of Assyria, and I will deliver thee two thousand horses, if thou be able on thy part to set riders upon them." It may be inferred from this passage, that cavalry was not extensively used by the Jews. The horses alluded to in the 3d verse of the 14th chapter of Hosea, are probably to be taken in connection with Assyria, mentioned in the previous part of the verse. "Asshur shall not save us; we will not ride upon horses." It is remarkable that there is no mention in the Bible of Arab horses, afterwards so celebrated. The Arabs in the army of Xerxes were mounted on camels, and were placed in the rear, because, says Herodotus, the camels frightened the horses (lib. vii. c. 87).

‡ Birch's Statistical Tablet of Karnak, p. 32.

§ The magnificent description of the war-horse in Job (ch. xxxix.), shows that horses of the noblest breed were, at a very early period, not only known in Syria, but used in battle.

|| Habakkuk, i. 8.



A HORSEMAN PURSUED BY ASSYRIAN WARRIORS. KOUYUNLIK, FROM A CAST IN THE BRITISH MUSEUM.

THE NEW YORK
PUBLIC LIBRARY.
ASTOR LENOX AND
TILDEN FOUNDATIONS.

bulls, goats, and stags, so frequently introduced into their bas-reliefs; it is highly probable, therefore, that they carefully copied the forms of their horses, and showed the points for which they were most distinguished. It is not unlikely that the plains watered by the Tigris and Euphrates, producing during the winter and spring the richest pasturage, were at the earliest period as celebrated as they are now for the rearing of horses; particularly when so large a supply must have been required for the cavalry and chariots of the Assyrian armies. At a later period, indeed, we find the plains of Babylonia furnishing horses to the Persians, both for the private use of the king and for his troops. It may, therefore, be conjectured that they were of the most noble and celebrated breeds; for the Persians, being masters of the greater part of Asia and of Egypt, could have obtained horses, had they found better, from elsewhere.* According to Herodotus, the stud maintained by the Babylonians for the Persian monarch included 800 stallions and 16,000 mares.† It may have been derived by the Persians from those whom they conquered; and it is not improbable that the Assyrians themselves supplied their cavalry from similar studs kept up near Babylon, or in other parts of the Mesopotamian plains. Amongst the objects of tribute brought by the Ruten-nu to the Egyptians, in the time of Thothmes III., are particularly mentioned brood-mares;‡ and this people, it will be shown, are supposed to have inhabited Assyria Proper, or some country immediately adjacent.

* According to Xenophon (*Cyrop.* lib. i. c. 3) it was very difficult to breed horses in Persia Proper; and it was a rare thing to see a horse in the country, which was too mountainous for riding. This must apply only to the most western and northern provinces; but even this part of Persia now produces a very good horse, probably originally bred from the Turcoman and Arab. The site of the Nisæan plains, so celebrated for their horses, has not yet been satisfactorily determined. Major Rawlinson believes them to have been somewhere in the mountains of Luristan. (*Notes on a March through Susiana: Journal of the Geographical Society.*)

† *Lib.* i. c. 192.

‡ Birch's *Memoir on the Statistical Tablet of Karnak*, p. 44.

CHAPTER V.

As the Assyrians possessed disciplined and organized troops, it is probable that they were also acquainted, to a certain extent, with military tactics, and that their battles were fought upon some kind of system. We know that such was the case with the Egyptians; and their monuments show that amongst their enemies, also, there were nations not unacquainted with the military science. They had bodies of troops in reserve; they advanced and retreated in rank, and performed various manœuvres. Although, in the Assyrian sculptures, we have no attempt at an actual representation of the general plan of a battle, as in some Egyptian bas-reliefs, yet, from the order in which the soldiers are drawn up before the castle walls, and from the phalanx which they then appear to form, it seems highly probable that similar means were adopted to resist the assaults of the enemy in the open field.

The king himself, attended by his vizir, his eunuchs, and principal officers of state, was present in battle, and not only commanded, but took an active part in the affray. Even Sardanapalus, when called upon to place himself at the head of his armies to meet the invading Medes, showed a courage equal to the occasion, and repulsed his enemies. Like the Persian monarchs who succeeded him in the dominion of Asia, the Assyrian king was accompanied to the war, however distant its seat might be, by his wives, his concubines, and his children, and by an enormous retinue of servants. Even his nobles were similarly attended. Their couches were of gold

and silver, and the hangings of the richest materials. Vessels of the same precious metals were used at their tables; their tents were made of the most costly stuffs, and were even adorned with precious stones.* They were also accompanied by musicians, who are represented in the sculptures as walking before the warriors, on their triumphant return from battle.

The army was followed by a crowd of sutlers, servants, and grooms; who, whilst adding to its bulk, acted as an impediment upon its movements, and carried ruin and desolation into the countries through which it passed. This multitude could not even depend entirely for supplies upon the inhabitants, whom they unmercifully pillaged; but provisions in great abundance, as well as live stock, were carried with them. Holofernes, in marching from Nineveh with his army, took with him "camels and asses for their carriage, a very great number, and sheep, and oxen, and goats without number for their provision; and plenty of victuals for every man."†

Quintus Curtius‡ thus describes the march of a Persian army:—The signal was given from the tent of the king, on the top of which, so as to be seen by all, was placed an image of the sun, in crystal. The holy fire was borne on altars of silver, surrounded by the priests chanting their sacred hymns. They were followed by three hundred and sixty-five youths, according to the number of the days in the year, dressed in purple garments. The chariot, dedicated to the supreme deity

* The canopy or tent of Holofernes was of purple, gold, and emeralds, and precious stones; and every man had gold and silver (vessels) out of the king's house. Judith, x. 24. This book contains an interesting account of the luxurious manner of living of the great Assyrian warriors, confirming what has been said in the text, and showing that the Persians were, in this respect, as almost in every other, imitators of the Assyrians. Herodotus (lib. ix. c. 82 and 83) describes the equipage, furnished with gold and silver, and with various colored hangings, and the gold and silver couches and tables, found in the tents of Mardonius after the defeat of the Persian army. They had been left by Xerxes when he fled from Greece.

† Judith, ii. 17.

‡ Lib. iii. c. 3; and compare Herodotus's description of the army of Xerxes, i. vii. c. 61.

(Jovi), or to the sun, was drawn by snow-white horses, led by grooms wearing white garments, and carrying golden wands. The horse especially consecrated to the sun was chosen from its size.* It was followed by ten chariots, embossed with gold and silver, and by the cavalry of twelve nations, dressed in their various costumes, and carrying their peculiar arms. Then came the Persian immortals, ten thousand in number, adorned with golden chains, and wearing robes embroidered with gold, with long-sleeved tunics, all glittering with precious stones. At a short interval fifteen thousand nobles, who bore the honorable title of relations of the king, walked in garments which, in magnificence and luxury, more resembled those of women than of men. The doryphori (a chosen company of spearmen) preceded the chariot in which the king himself sat, high above the surrounding multitude. On either side of this chariot were the effigies of the gods in gold and silver. The yoke was inlaid with the rarest jewels. From it projected two golden figures of Ninus† and Belus, each a cubit in length. A golden eagle with outspread wings was placed between them. The king was distinguished, from all those who surrounded him, by the magnificence of his robes, and by the cidaris, or mitre, upon his head. By his side walked two hundred of his most noble relations. Ten thousand warriors, bearing spears, whose staffs were of silver and heads of gold, followed the royal chariot. The king's led horses, forty in number, and thirty thousand footmen, concluded the procession. At the distance of one stadium, followed the mother and wife of the king, in chariots. A crowd of women, the handmaidens and ladies of the queens, accompanied them on horseback.

* That the custom of dedicating chariots and horses to the sun prevailed in Asia long before the Persian domination, we learn from the passage in 2 Kings, xxiii. 11, where Josiah is described as taking away the horses that the kings of Judah had given to the sun, at the entering in of the house of the Lord, by the chamber of Nathan-Melech, the chamberlain, which was in the suburbs, and burning the chariots of the sun with fire.

† Some MSS. have "War and Peace." Ninus was an emendation first suggested by Scaliger.

Fifteen cars, called *armamaxæ*, carried the children of the king, their tutors and nurses, and the eunuchs. The king's three hundred and sixty concubines, who accompanied him, were adorned with royal splendor. Six hundred mules, and three hundred camels bore the royal treasury, guarded by the archers. The friends and relations of the ladies were mingled with a crowd of cooks, and servants of all kinds. The procession was closed by the light-armed troops.

The armies were provided with the engines and materials necessary for the siege of the cities they might meet with, in their expedition. If any natural obstructions impeded the approach to a castle, such as a forest or a river, they were, if possible, removed. Rivers were turned out of their courses if they impeded the operations of the army;* and warriors are frequently represented in the sculptures, cutting down trees which surround a hostile city.

The first step, on attacking a hostile city, was probably to advance the battering-ram. If the castle was built, as in the plains of Assyria and Babylonia, upon an artificial eminence, an inclined plane, reaching to the summit of the mound, was formed of earth, stones, or trees, and the besiegers were then able to bring their engines to the foot of the walls. This road was not unfrequently covered with bricks, forming a kind of paved way, up which the ponderous machines could be drawn without much difficulty.

This mode of reaching the walls of a city is frequently alluded to by the prophets, and is described by Isaiah:—"Thus saith the Lord concerning the king of Assyria, He shall not come into this city, nor shoot an arrow there, nor come before it with shields, *nor cast a bank against it.*"† Similar

* In the *Stratagemata* of Frontinus (l. iii. c. 7, s. 5), Semiramis, like Cyrus, is said to have taken Babylon by turning off the river.

† Chap. xxxvii. 33; and compare 2 Kings, xix. 32; Jeremiah, xxxii. 24, and xxxiii. 4. The shields mentioned by the prophet were probably the large kind made of wicker-work, represented in the Nimroud sculptures, and used exclusively for a siege; those carried by the warriors in battle being smaller, and generally round.

approaches were used by the Egyptians.* They not only enabled the besiegers to push their battering-rams up to the castle, but at the same time to escalate the walls, the summit of which might otherwise have been beyond the reach of their ladders.

The battering-rams were of several kinds. Some were joined to movable towers, which held warriors and armed men. The whole then formed one great temporary building, the top of which is represented in the sculptures as on a level with the walls, and even turrets, of the besieged city. In some bas-reliefs the battering-ram is without wheels; it was then perhaps constructed on the spot, and was not intended to be removed. The movable tower was probably sometimes unprovided with the ram; but I have not met with it so represented in the sculptures. When Nebuchadnezzar, king of Babylon, besieged Jerusalem, he "built forts against it round about."† These forts or towers, if stationary, were solidly constructed of wood; if movable, they consisted of a light frame covered with wicker-work. The Jews were forbidden to cut down and employ, for this purpose, trees which afforded sustenance to man. "Only the trees which thou knowest that they be not trees for meat, thou shalt destroy and cut them down: and *thou shalt build bulwarks against the city that maketh war with thee until it be subdued.*"‡

When the machine containing the battering-ram was a simple framework, and did not form an artificial tower, a cloth or some kind of drapery, edged with fringes, and otherwise ornamented, appears to have been occasionally thrown over it. Sometimes it may have been covered with hides. It moved either on four, or on six wheels, and was provided with one ram or with two. The mode of working the rams can-

* Ezekiel, xvii. 17. "Neither shall Pharaoh with his mighty army and great company make for him in the war, by casting up mounts, and building forts, to cut off many persons."

† Jeremiah, lii. 4.

‡ Deuteronomy, xx. 19, 20.



Bas-relief representing Warriors before a besieged City. A Battering-ram drawn up to the Walls, and Captives impaled. (Centre Palace, Nimrod.)

not be determined from the Assyrian sculptures. It may be presumed, from the representations in the bas-reliefs, that they were partly suspended by a rope fastened to the outside of the machine, and that men directed and impelled them from within. Such was the plan adopted by the Egyptians, in whose paintings the warriors, working the ram, may be seen through the frame.*

Sometimes this engine was ornamented by a carved or painted figure of the presiding divinity, kneeling on one knee and drawing a bow.†

* Wilkinson's Ancient Egyptians, vol. i. plate, p. 360.

† This device is seen on a battering-ram in a bas-relief, engraved in my "Monuments of Nineveh."

The artificial tower was usually occupied by two warriors; one discharged his arrows against the besieged, whom he was able from his lofty position to harass more effectually than if he had been below; the other held up a shield for his companion's defence. Warriors are not unfrequently represented as stepping from the machine to the battlements.

Ezekiel alludes to all these modes of attack. "Lay siege against it," he exclaims, speaking of the city of Jerusalem, "and build a fort against it, and cast a mount against it; set the camp also against it, and set battering-rams against it round about."*

Archers on the walls hurled stones from slings, and discharged their arrows against the warriors in the artificial towers; whilst the rest of the besieged were no less active in endeavoring to frustrate the attempts of the assailants to make breaches in their walls. By dropping a double chain or rope from the battlements, they caught the ram, and could either destroy its efficacy altogether, or break the force of its blows. Those below, however, by placing hooks over the engine, and throwing their whole weight upon them, struggled to retain it in its place.†

The besieged, if unable to displace the battering-ram, sought to destroy it by fire, and threw lighted torches, or fire brands, upon it. But water was poured upon the flames, through pipes attached to the artificial tower.

Other engines and instruments of war were employed by the besiegers. With a kind of catapult, apparently consisting of a light wooden frame covered with canvas or hides, they threw large stones and darts against the besieged, who, in their turn, endeavored to set fire to it by torches. A long staff with an iron head, resembling a spear, was used to force the stones out of the walls. Mines were also opened, and the as-

* Ch. iv. ver. 2.

† Uzziah made large machines for battering walls, and instruments to cast stones, and *grappling irons*, and other instruments. (2 Chron. xxvi. 15, and Josephus, lib. ix. c. 10.)

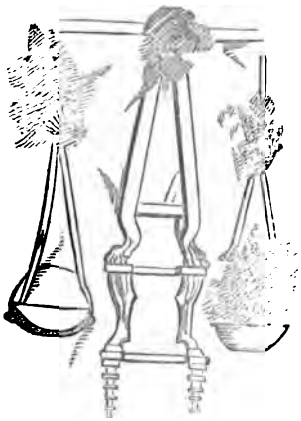

A PAIR OF SCALES FOR WEIGHING THE SPOIL. (Khorsabad. Page 284.

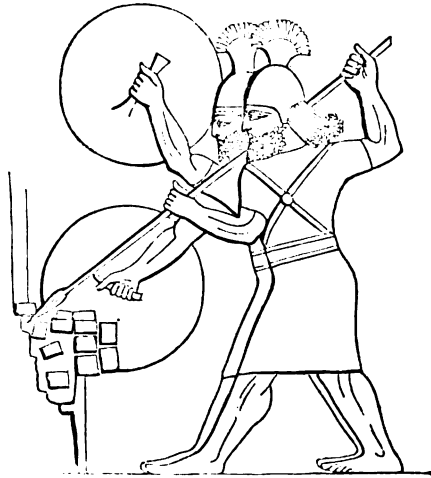

WARRIORS FORCING STONES OUT OF THE LOWER PART OF THE WALL OF A BESIEGED CITY. (S. W. Palace, Nimroud.) Page 289.



A BOAT CARRYING A CHARIOT AND MEN FLOATING ON INFLATED SKINS. Page 291.



COIN of uncertain origin, conjectured to belong to a City on the Syrian Coast during the Persian Occupation. Page 295.

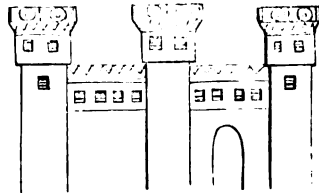

Castle of a Maritime People, probably the Tyrians. (Kouyunjik.) Page 296.

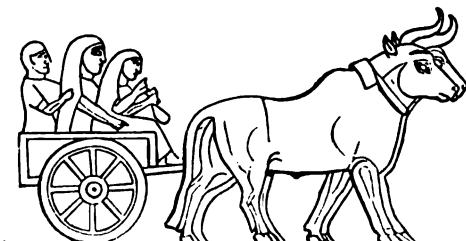

Captive women in a Cart drawn by Oxen. (Centre Palace, Nimroud.) p. 301. 284. VOL. II.

THE UNIVERSITY OF CHICAGO
LIBRARY
CHICAGO, ILL.
AND
BRANCHES.

THE NEW YORK
PUBLIC LIBRARY
ASTOR LENOX AND
TILDEN FOUNDATIONS.

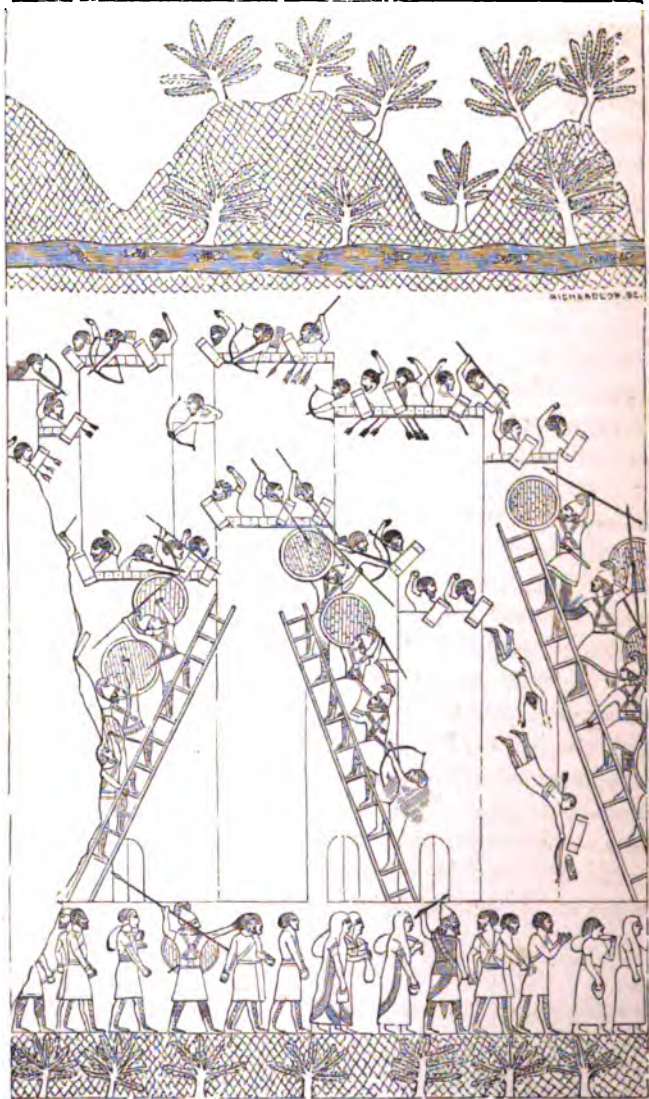

CITY TAKEN BY ASSAULT, AND THE INHABITANTS LED AWAY CAPTIVE.

(Kouyunjik.)

sailants sought to enter the castle through concealed passages.* Those who worked at them or advanced to the attack were perhaps protected by the *testudo*, as represented in the Egyptian paintings; but this defence is not seen in the Assyrian sculptures.

Attempts were made to set fire to the gates of the city by placing torches against them,† or to break them open with axes.

Mouning to the assault by ladders was constantly practised, and appears to have been the most general mode of attacking a castle; for ladders are found on those bas-reliefs, in which neither the battering-ram nor other engines are introduced.‡ They reached to the top of the battlements, and several persons could ascend them at the same time. Whilst warriors, armed with the sword and spear, scaled the walls, archers posted at the foot of the ladders kept the enemy in check, and drove them from the walls.

The troops of the besieging army were ranged in ranks below. The king was frequently present during the attack. Descending from his chariot, which remained stationary at a short distance behind him, he discharged his arrows against the enemy. He was attended by his shield-bearer, and eunuchs, one of whom generally held over him the emblem of royalty, the umbrella, whilst the others bore his arms. He is sometimes represented in his chariot, superintending the operations, or repulsing a sally. Warriors of high rank likewise came in chariots, accompanied by their shield-bearers and charioteers.§ The vizir and the chief of the eunuchs are frequently seen in the midst of the combatants.

* All these modes of attack and defence are represented in the bas-relief before alluded to.

† "Abimelech went hard unto the door of the tower to burn it with fire." (Judges, ix. 52.)

‡ Scaling ladders appear in Egyptian sculptures as early as in the nineteenth dynasty. Ramses III. is seen taking a city by their means, at Medinat Habou.

§ "The choicest valleys shall be full of chariots, and the horsemen shall set themselves in array at the gate." (Isaiah, xxii. 7.)

The besieging warriors were protected, as I have already mentioned, by large shields of wicker-work, sometimes covered with hides, which concealed the entire person. Three men frequently formed a group; one held the shield, a second drew the bow, and a third stood ready with a sword to defend the archer and shield-bearer, in case the enemy should sally from the castle.

The besieged manned the battlements with archers and slingers, who discharged their missiles against the assailants. Large stones and hot water were also thrown upon those below.*

When the battering-ram had made a breach, and the assault had commenced, the women appeared upon the walls; and, tearing their hair or stretching out their hands, entreated for mercy. The men are not unfrequently represented as joining in asking for quarter. When the assailants were once masters of the place, an indiscriminate slaughter appears to have succeeded, and the city was generally given over to the flames. In the bas-reliefs warriors are seen decapitating the conquered, and plunging swords or daggers into their hearts, holding them by the hair of their heads. The prisoners were either impaled and subjected to horrible torments, or carried away as slaves. The manner of impaling adopted by the Assyrians, appears to have differed from that still in use in the East. A stake was driven into the body immediately under the ribs.† In a bas-relief discovered at Khorsabad, a man was represented flaying a prisoner with a semicircular knife.‡

The women, children, and cattle were led away by the conquerors; and that it was frequently the custom of the Assyrians to remove the whole population of the conquered

* A woman from the battlement of Thebez cast a millstone upon Abimelech's head, and brake it. (Judges, ix. 53.)

† See woodcut, p. 283. When Darius took Babylon he impaled 3000 prisoners. (Herod. iii. 159.)

‡ The Scythians scalped and flayed their enemies, and used their skins as horse-trappings. (Herod. iv. 64.)

country to some distant part of their dominions, and to replace it by colonies of their own, we learn from the treatment of the people of Samaria.* Eunuchs and scribes were appointed to take an inventory of the spoil. They appear to have stood near the gates, and wrote down with a pen, probably upon rolls of leather, the number of prisoners, sheep, and oxen, and the amount of the booty, which issued from the city. The women were sometimes taken away in bullock-carts, and are usually seen in the bas-reliefs bearing a part of their property with them—either a vase or a sack, perhaps filled with household stuff. They were sometimes accompanied by their children, and are generally represented as tearing their hair, throwing dust upon their heads, and bewailing their lot.

After the city had been taken, a throne for the king appears to have been placed in some conspicuous spot, within the walls. He is represented in the sculptures as sitting upon it, attended by his eunuchs and principal officers, and receiving the prisoners brought bound into his presence. The chiefs prostrate themselves before him, whilst he places his foot upon their necks, as Joshua commanded the captains of Israel to put their feet upon the necks of the captive kings.† This custom long prevailed in the East. In the rock-sculpture of Behistun, Darius is seen with his foot upon the neck of Gomates, the rebellious Magian, who declared himself to be Bar-

* 2 Kings, xvii. 24. According to Josephus (lib. ix. c. 12), Tiglath-pileser having taken Damascus, removed all the inhabitants, and peopled the city with his own subjects. So, also, when Nebuchadnezzar took Jerusalem, he carried away all the people captive, and "burned the king's house and the houses of the people with fire, and brake down the walls." (Jeremiah, xxxix. 8, 9.)

† "And it came to pass, when they brought out those kings unto Joshua, that Joshua called for all the men of Israel, and said unto the captains of the men of war which went with him, Come near, put your feet upon the necks of these kings. And they came near, and put their feet upon the necks of them." (Joshua, x. 24.) To make "a footstool of thine enemies" is a common biblical expression for triumph.

tius, the son of Cyrus.* When inferior prisoners were captured, their hands were tied behind, or their arms and feet were bound by iron manacles.†

They were urged onwards by blows from the spears, or swords, of the warriors to whom they were intrusted. In a bas-relief from Khorsabad, captives are led before the king by a rope fastened to rings passed through the lip and nose.‡

In the sculptures of Khorsabad, and Kouyunjik, captives are seen bringing small models of their cities to the victorious king, as a token of their subjection. Similar models are borne in triumphal processions.

The heads of the slain were generally collected, and brought either to the king or to an officer, who took account of their number.§ This mode of reckoning the loss of the enemy was long resorted to in the East.

As soon as the soldiers entered the captured city, they began to plunder, and then hurried away with the spoil. They led off the horses, carried forth on their shoulders furniture, and vessels of gold, silver, and other metals; and made prisoners of the inhabitants, who, probably, became the property of those who seized them.

The Assyrian warriors are seen in the sculptures bearing

* Major Rawlinson's Memoir on the Inscription at Behistun. (Journal of the Royal Asiatic Society.)

† "To bind their kings with chains, and their nobles with fetters of iron." (Psalm cxlix. 8.) These fetters were sometimes made of brass. "They put out the eyes of Zedekiah, and bound him with fetters of brass, and took him to Babylon." (2 Kings, xxv. 7.) Samson was also bound with fetters of brass. (Judges, xvi. 21.)

‡ This sculpture illustrates the passage in 2 Kings, xix. 28. "I will put my hook in thy nose, and my bridle in thy lips." The king is represented in a bas-relief as holding a rope fastened to a ring through the lips of a prisoner, one of whose eyes he appears to be piercing with his spear.

§ See woodcut p. 147. When Ahab's seventy sons were killed, their heads were cut off, and brought in baskets to Jezreel. They were afterwards laid "in two heaps at the entering in of the gate." (2 Kings, x. 8.) The Egyptians generally counted by hands.

away in triumph the idols of the conquered nations, or breaking them into pieces, weighing them in scales, and dividing the fragments.* Thus Hosea prophesied that the calf, the idol of Samaria, should be carried away by the Assyrians.†

When the city had been sacked, it was usually given up to the flames, and utterly destroyed. The surrounding country was also laid waste.‡ If it had been a capital—a place of strength and renown—it was seldom rebuilt on the same spot; which was avoided, as unfortunate, by those who survived the catastrophe and returned to the ruins.

Ezekiel, in prophesying the destruction of Tyre by Nebuchadnezzar, has faithfully recorded the events of a siege, and the treatment of the conquered people. His description illustrates the bas-reliefs of Nimroud;—

“Thus saith the Lord God; Behold, I will bring upon Tyrus Nebuchadrezzar king of Babylon, a king of kings, from the north, with horses, and with chariots, and with horsemen, and companies, and much people. He shall slay with the sword thy daughters in the field: and he shall make a fort against thee, and cast a mount against thee, and lift up the buckler against thee. And he shall set engines of war against thy walls, and with his axes he shall break down thy towers. By reason of the abundance of his horses, their dust shall cover thee: thy walls shall shake at the noise of the horsemen, and of the wheels, and of the chariots, when he shall enter

* In a bas-relief from Khorsabad. “Babylon is taken, Bel is confounded, Merodach is broken in pieces; her idols are confounded, her images are broken in pieces.” (Jeremiah, l. 2.) Compare Isaiah, xxi. 9.

† Ch. x. ver. 6. And Jeremiah declares that the Babylonians shall kindle a fire in the houses of the gods of the Egyptians, “and burn them, and carry them away captive.” (Ch. xliii. ver. 12.) In a bas-relief from the centre palace of Nimroud, the Assyrian warriors were represented carrying away the image of a bird.

‡ When Holofernes took Damascus “he went into the plain in the time of wheat harvest, and burnt up all the fields, and destroyed the flocks and herds; also he spoiled the cities, and utterly wasted the countries, and smote all the young men with the edge of the sword” (Judith, ii. 27.)

into thy gates, as men enter into a city wherein is made a breach. With the hoofs of his horses shall he tread down all thy streets: he shall slay thy people by the sword, and thy strong garrisons shall go down to the ground. And they shall make a spoil of thy riches, and make a prey of thy merchandise; and they shall break down thy walls, and destroy thy pleasant houses: and they shall lay thy stones, and thy timber, and thy dust, in the midst of the water.”*

Although the Assyrians were properly an inland people, yet their conquests and expeditions, particularly at a later period, brought them into contact with maritime nations. We consequently find, on the monuments of Khorsabad and Kouyunjik, frequent representations of naval engagements and operations on the sea-coast. In the most ancient palace of Nimroud, only bas-reliefs with a river have been discovered; they furnish us, however, with the forms of vessels, evidently of Assyrian construction—all those in the sculptures of Khorsabad and Kouyunjik belonging probably to allies or to the enemy. It may be presumed that the rivers navigated by the early Assyrians, and represented in their bas-reliefs, were the Tigris, Euphrates, and Khabour.

Herodotus thus describes the Babylonian vessels of a later period: “The boats used by those who come to the city (Babylon) are of a circular form, and made of skins. They are constructed in Armenia, in the parts above Assyria. The ribs of the vessels are formed of willow boughs and branches, and covered externally with skins. They are round like a shield, there being no distinction between the head and stern. They line the bottoms of their boats with reeds (or straw), and, taking on board merchandise, principally palm wine (or rather spirits extracted from the date), float down the stream. The boats have two oars, one man to each; one pulls to him, the other pushes from him. These vessels are of different dimensions; some of them are so large that they bear freight to the

* Ch. xxvi. ver. 7-12.

value of 5000 talents. The smaller have one ass on board ; the larger, several. On their arrival at Babylon the boatmen dispose of their goods, and also offer for sale the ribs and the reeds (or straw). They then load their asses with the skins, and return with them to Armenia, where they construct new vessels.”*

I was, at one time, inclined to believe that the description of Herodotus applied to the rafts still constructed on the rivers of Mesopotamia, and used, it will be remembered, for the conveyance of the sculptures from Nimroud to Busrah.† The materials of which they are made are precisely those mentioned by the Greek historian, and they are still disposed of, at Baghdad, in the same way as they were in his day at Babylon. But the boats which excited the wonder of Herodotus seem to have been more solidly built, and were capable of bearing animals, to which purpose the rafts now in use could not be applied. They were probably more like the circular vessels now used at Baghdad, built of boughs, and sometimes covered with skins, over which bitumen is smeared, to render the whole waterproof. The boats commonly employed for the conveyance of goods and animals, on the lower part of the Tigris and Euphrates, and for ferries on all parts of those rivers, are constructed of planks of poplar wood, rudely joined together by iron nails or wooden pins, and coated with bitumen.

In a bas-relief from the most ancient palace of Nimroud, two kinds of boats are introduced. The larger vessel contains the king in his chariot, with his attendants and eunuchs. It is both impelled by oars, and is towed by men. The smaller resembles that described by Herodotus. The head does not differ in form from the stern, and two men sit face to face at the oars.

In this bas-relief are also represented men supporting themselves upon inflated skins—a manner of crossing rivers still generally practised in Mesopotamia.

* Lib. i. c. 194.

† See p. 79 of this volume.

The larger boats were steered by a long oar; to the end of which was fastened a square or oval board. This oar was held in its place by a rope, fastened to a wooden pin at the stern. By this contrivance the steersman had considerable control over the vessel, and could impel it, or turn the head at pleasure. This mode of steering, and propelling boats, still prevails on the Mesopotamian rivers.

It may be presumed, that the Assyrians soon acquired a more intimate acquaintance with the art of ship-building, than is displayed by these rude vessels; although they may not have put their knowledge in practice on the rivers. A tradition has even assigned the invention of ships to Semiramis.* In a bas-relief, from the centre palace of Nimroud, vessels were represented with a mast, and with a carved prow and stern, both ornamented with the head of an animal or bird, probably in metal. They were also impelled by oars; and from the relative size between them and the figures, they do not appear to have been larger than the rude boats of the earlier monuments. The mast was retained in its position by two ropes. The oars were long, and the blade projected at an angle with the handle. They were probably used like paddles, which they resemble, indeed, in form. Although these ships were near a castle, from the fish and marine monsters in the water, it would appear that the sea, and not a river, was represented.

The vessels of the Khorsabad sculptures, show a considerable advance in the knowledge of ship-building. That they did not belong to the Assyrians, but to some allied nation, appears to be indicated by the peculiar costume of the figures in them.† The form of the vessel is not inelegant: it is that of a sea monster—the prow being in the shape of the head of a horse, and the stern in that of the tail of a fish. Several men

* Pliny, lib. vii. 417. That the Chaldees were skilful ship-builders, "and ev-
 ulted in their ships," we learn from Isaiah, xliii. 14.

† Small boats similarly constructed are, however, introduced into a bas-relief,
 which appears to represent a scene on an Assyrian river or lake. (See woodcut,
 p. 216.)



A Ship. (Khorsabad.)

stand at the oars. The mast, supported by two ropes, appears to be surmounted by a box, or what is technically called a crow's nest; which, in the galleys of the Egyptians, frequently held an archer.

From the nature of the animals and fish swarming in the water round the vessels, the Khorsabad bas-reliefs evidently represent an event on the sea, and not on a river. A castle stands on the shore, and the ships are employed in bringing planks, and beams of wood, to form an artificial approach, by which the besiegers may reach the walls. Some of these planks are dragged, at the stern of the vessels, by ropes; others are on deck. In the sea is seen a figure with the human form to the waist, and with the tail of a fish. The horned cap connects it with the sacred emblems of the Assyrian sculptures, and we may, probably, recognize in it Oannes, or the Chaldæan sea god.*

* A sea-piece, such as that described in the text, is amongst the Assyrian bas-reliefs in the Louvre.

But it was in the sculptures of Kouyunjik, that vessels were found represented in the greatest perfection. From their position, in the bas-reliefs, with reference to the besieging army, it would appear that they did not belong to the Assyrians themselves; but to a people with whom they were at war, and whom they appear to have conquered. That the event recorded occurred on the sea, and not on a river, was shown by the nature of the fish and marine animals; such as the star jelly fish, and a kind of shark, introduced into the sculpture. A castle stood on the shore; and the inhabitants, attacked on the land side, were deserting their city, and taking refuge in their vessels.

The larger galleys of these bas-reliefs were of peculiar form, and may, I think, be identified with the vessels used to a comparatively late period, by the inhabitants of the great maritime cities of the Syrian coast—by the people of Tyre and Sidon. Their height out of the water, when compared with the depth of keel, was very considerable. The forepart rose perpendicularly from a low sharp prow, which resembled a ploughshare, and being of iron or some other metal, may have been intended, like that of the Roman galley, to sink or disable the enemy's ships. The stern was curved from the keel, and rose high above the upper deck. There were two tiers of rowers; but whether they were divided by a deck, or merely sat upon benches placed at different elevations in the hold, does not appear from the sculptures. Above the rowers was a deck, on which stood the armed men. These vessels had only one mast, to the top of which was attached a very long yard, held by ropes. In the sculptures, the sails were represented as furled. The number of rowers in the bas-reliefs was generally eight on a side. Only the heads of the upper tier of men were visible; the lower tier was completely concealed, the oars passing through small apertures, or port-holes, in the sides of the vessel.

These galleys nearly resemble in form the vessels represented on certain coins of ancient date; which, although not yet satisfactorily classed, evidently belong to the period of the

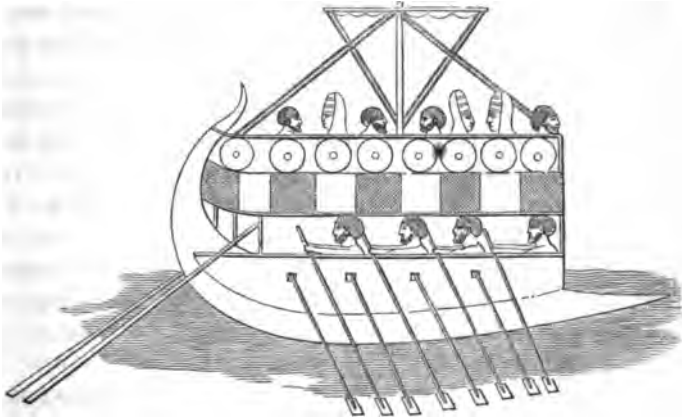

Ship. (Kouyunjik.)

Persian supremacy in Asia. This may be inferred by their having on one side the effigy of the king in his chariot, attended by his charioteer, as found on darics and on cylinders undoubtedly Persian.

These coins, which are rare, have been discovered both in Babylonia and on the coasts of Cilicia and Syria,* and were probably struck by the cities on the shores of the Mediterranean during their subjection to Persia. There are many peculiarities in the figures, groups, and inscriptions upon them, to connect them with other coins of the same class, generally known as "the uncertain of Cilicia;" all of which may perhaps be assigned to cities of Phœnician origin, either in Asia Minor, Syria, or Cyprus.† The mere fact of these coins hav-

* Those in the British Museum, from the collection of Mr. Rich, were principally found in the bed of the Euphrates, near Babylon; but, as they were accompanied by other coins of a much later (I think of the Arsacid or Sassanian) period, they must have been deposited there long after the fall of the first Persian empire, and consequently long subsequent to the time of their coinage.

† Almost all ancient cities of Asia Minor and the adjacent islands, whose names commenced with "Cor," stood upon the sea-coast. This word may therefore, have some reference to their position, and may point to a Phœnician origin. It may, perhaps, be connected with the Hebrew כָּרַת, "to dig" and the Arabic حَوْز or حَار

ing been occasionally found on the banks of the Euphrates, is not sufficient to prove that they were coined in Babylon, of which city we have no ancient money.

The galleys, both on these coins and in the Kouyunjik bas-reliefs, are further identified with the vessels of the Syrian coasts, by the coins of Sidon of a later period, which bear on one side a galley similarly constructed, and on the other the head of an Assyrian goddess.

The castles of the maritime people, whose conquest is recorded by the Kouyunjik bas-reliefs, are distinguished by the shields hung round the walls. This peculiarity appears to illustrate a passage in Ezekiel concerning Tyre: "The men of Arvad with thine army were upon the walls round about, and the Gammadims were in thy towers: *they hanged their shields upon thy walls round about.*"* We have no other allusion to this custom in holy writ; and its particular mention in connection with Tyre, may perhaps be considered a further proof in favor of the identification of the event recorded by the sculptures, with a siege and capture of that city.

Around the sides of the vessels were also suspended the shields of the warriors; and a similar custom appears to have prevailed amongst other nations in the infancy of the art of ship-building.†

The Tyrian vessels were constructed of the most costly

the mouth of a river, and bay of the sea, still used on the Arabian coast; for instance, the mouths of the Euphrates and Karoon are known as the Khor-mousa, the Khor-bamishere, &c. In Pontus were Cor-alla, Cor-dyla, Cot-yora; in Paphlagonia, Car-usa, Car-ambes; in Cyprus, Core and Cor-ineum; in Cilicia, Cor-yceus, Cor-acesium; in Crete, the promontory and city of Cor-yceus; in Ionia, Cor-yceus; the Cor-icumlittus and Cor-ydalla in Lycia; in Rhodes, Cor-ymbia and Cor-dylusa; in Messenia, Cor-yphaesium. The sense of cavern, also included in the word, will well suit Cor-yceus in Cilicia, and the celebrated cave of the same name in Phocis. The derivation of חורר "a hole;" or כרדן "to dig," may indicate an artificial harbor, and an early Phœnician settlement.

* Ezekiel, xxvii. 11.

† On the sides of the upper deck of the Chinese junks are suspended the shields and arms of the crew.

1000
1000
1000

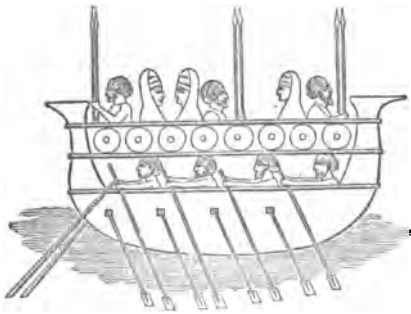

A GALLEY. (Kouyunjik.) Page 297.

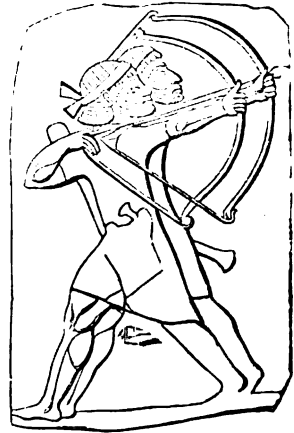

ENEMIES OF THE ASSYRIANS
Discharging their Arrows to land
them. (Kouyunjik.) Page 305.



Flying Warrior Discharging an Arrow. (N. W. Palace, Nimroud.)
Page 299.

materials. The sails were of "fine linen with embroidered work from Egypt;" and the ornaments were of "blue and purple from the isles of Elisha." The benches were of ivory, and, it will be remarked, were made by Assyrian workmen, of whose skill we have full proof in the beautiful carvings from Nimroud. The oars were of the wood of the oaks of Bashan, the planks of fir-trees from the mountain of Senir, and the masts of cedar of Lebanon. The people of Zidon and Arvad were employed as mariners, and the management and sailing of the ship were confided to the pilots of Tyre, who, through long experience, were well versed in the art of navigation, and were consequently looked upon as "the wise men" in a city of sailors and merchants.* In these vessels the Phœnicians coasted along the shores of the Mediterranean, and carried on an active commerce with very distant nations; establishing their colonies, and diffusing far and wide their civilization, their arts, and their language.

Besides the vessel I have described, a smaller is represented in the same bas-reliefs. It has also a double tier of rowers; but the head and stern are differently constructed from those of the larger galley, both being of the same shape, and not to be distinguished. They rise high above the water, and are flat at the top, with a beak projecting outwards. This vessel had no mast, and was impelled entirely by oars. On the upper deck are seen warriors armed with spears, and women.

It is impossible to determine, from the sculptures, the size of the vessels; as the relative proportions between them, and the figures they contain, are not preserved. It is most probable that the four rowers in each tier are merely a conventional number; and we cannot, therefore, conjecture the length of the ship from them.

No representations of naval engagements, as on the monu-

* The 27th chapter of Ezekiel contains a complete description of the vessels of the Tyrians, and is a most important and interesting record of the commercial intercourse of the nations of antiquity.

ments of Egypt, have yet been discovered in the Assyrian sculptures. It is most probable that, not being a maritime people, the Assyrians made use of the fleets of their allies in their expeditions by sea; as the Persians did afterwards, furnishing warriors to man the ships.

The bas-reliefs hitherto discovered in Assyria, principally record the wars and triumphs of the Assyrians, and represent their achievements in battle. Their enemies, therefore, are frequently portrayed in them. On the earlier monuments the conquered are marked by two distinct costumes. In the series of sculptures, forming the southern side of the great hall in the northwest palace,* they are principally distinguished by the absence of helmets and armor. A simple fillet, or band, binds their temples, and in no instance have they any other head-dress. Their long hair, and beards, are less carefully and elaborately arranged than those of the Assyrians; but this distinction may be attributed to the malice of the sculptor, who appears to have wilfully disfigured the pictures of the enemies of his nation, or at least to have bestowed less care upon them than upon those of his own people. They wore short tunics, descending to the knee. Their sandals were peculiar, formed apparently by a number of straps, or cross-bars, from the instep to the sole of the foot. They used the same arms as the Assyrians, with the addition of the sling—a weapon which is not seen in the hands of the conquerors in the most ancient bas-reliefs. The women were clothed in long embroidered robes descending to the ankles, fitting tight over the breast (which are indicated in the sculptures), and confined at the waist by a girdle. The hair fell loosely over their shoulders. The conquered have no very marked peculiarity in the form of their features, to distinguish them from the Assyrians; and, if their race or nation was indicated, it was, probably, as on the monuments of Egypt, by color, which has completely disappeared. There is nothing in the bas-reliefs to show the re-

* Hall B, plan 3.

gion they inhabited. They possessed walled cities, some standing on a river; and their country was apparently wooded, as trees are generally represented in the sculptures. It may be presumed that they were not far behind their conquerors in civilization; for they were acquainted with the use of the pulley; and, it may be inferred from their castle-gates, with the principle of the arch; and they possessed chariots drawn by horses nearly as richly caparisoned as those of the Assyrians. Their chariot-wheels had eight, or even twelve spokes, differing in this respect from those of the conquerors. On a bas-relief, representing the captives brought before the king, we find—amongst vases and bowls of elegant shapes—objects resembling elephants' tusks, bundles of precious wood, and shawls; this would appear to connect the people described with some Asiatic nation far to the east of Assyria.

The other conquered people, represented in the earliest sculptures of Nimroud, are chiefly distinguished by their conical caps; not pointed, like the Assyrian helmet, but rounded at the top, and apparently made of felt, or bands of linen. They wore high boots reaching half way up the calf of the leg, and turned up at the toes, like those still in use in Persia and Turkey; and were dressed either in short tunics, scarcely covering the knee, or in robes descending to the ankles. Their hair, although long, was not curled, but was gathered into a bunch behind; the end being either tucked under the cap, or confined by a band passing round the temples. On the northern side of the great hall of the northwest palace, were discovered two bas-reliefs,* representing the siege of a city belonging to this people, and standing on the banks of a river. Beneath the walls the armies of the two nations are seen in battle—the Assyrians in chariots, their enemies chiefly on horses. One of the horsemen is flying, and turns back, whilst

* Nos. 27 and 28, hall B, plan 3. No. 27 will be placed in the British Museum.

his horse is at full speed, to discharge an arrow against his pursuers, like the Parthians of old.*

The bas-reliefs in the outer chambers, to the north of the great hall,† represent the same people. In those sculptures, it will be remembered, the captives bring monkeys, amongst other objects of tribute. The tribute-bearers on the obelisk, also, appear to belong to this nation; for they are similarly attired, and also bring monkeys. Other animals led by them, such as the elephant, rhinoceros, and Bactrian camel, evidently show that they came from some country far to the east of Assyria—either from India itself or from its confines; and we are naturally led to conjecture, that the monument was erected to celebrate the Indian expedition of one of the early Assyrian monarchs—the Ninus, Semiramis, or Ninyas of history. The other tribute appears to be elephants' tusks, shawls, precious woods, a kind of fruit or plant, and vessels probably of gold and silver. The inscription may record the conquest of many countries; and more nations than one may be represented by the figures bearing these various objects.

The unplaced bas-reliefs, discovered together near the great bulls in the centre of the mound, do not apparently celebrate the subjection of the same countries as the obelisk. This fact seems to me an additional reason for believing them to be of a later period than that monument, and than the bulls, on which the name of the son of the builder of the northwest palace

* "Fidentemque fugâ Parthum, versisque sagittis."

VING. *Georg.* 3.

And

— "Versis animosum equis
Parthum."

HOR. *Carm.* lib. i. ode xix.

Justin (lib. xli. c. 2) describes this mode of combating as peculiar to the Parthians, and very dangerous to those incautiously engaging in their pursuit. That the same custom existed at a very early period amongst the Persians, we learn from Xenophon. (*Anabasis*, book iii. ch. 3.) It is still the favorite mode of fighting of that people. It is called the *Kaikaj*. The Bakhtiyari, and other mountain tribes, are particularly skilful in it, and will hit a small mark, turning back and discharging their rifles whilst their horses are at full speed.

† Chambers D and E, plan 3.

THE NEW YORK
PUBLIC LIBRARY.
ASTOR, LENOX AND
TILDEN FOUNDATIONS.



ASSYRIAN HORSEMAN PURSUING A MAN, PROBABLY AN ARAB, ON A CAMEL, (Centre Ruins, Nimroud)

occurs. They record the subjugation of several nations. In some were represented warriors on fleet camels, fleeing from the Assyrians. Women, also mounted on camels, were seen escaping from their enemies.* The head-dress of the men was a simple fillet passing round the temples, the hair being either confined by it, or sometimes allowed to fall loose on the shoulders. They wore short tunics or aprons from the waist to the knee, the rest of the body being left naked. The women were clothed in robes descending to the ankles, and their hair was long. This people appears to have possessed large flocks of camels, sheep, goats, and horned cattle, and to have inhabited a country producing the palm-tree. As they used camels in war, we may conjecture that they were Arabs living either in the south of Mesopotamia, or in a part of the Arabian Peninsula.†

Another conquered people represented in these bas-reliefs dwelt in fortified cities, which stood on the banks of a river, and had palms within and without the walls. The men wore their hair loose, and were mostly armed with bows. After their cities had been captured, the women were taken away in square carts, drawn by oxen. These carts had wheels with eight spokes. From the palm-trees represented in the bas-reliefs, this people may have inhabited some part of Babylonia.

A third nation, whose subjugation is recorded, had cities or castles built on the tops of mountains. They wore helmets ornamented with a curved crest, and were armed with spears and bows.

A fourth possessed walled cities surrounded by lofty ramparts, and wore caps apparently formed of bands of linen, and resembling the Phrygian cap reversed. They were armed with spears and bows. The women are distinguished by

* The saddles of the camels appear to have consisted of a square pad, or seat, placed upon the hump.

† The Arabs, mounted on camels, formed a part of the great army of Xerxes, and the camel-riding Shasu (Arabs) are frequently mentioned in the monuments' inscriptions of Egypt.

hoods covering the head, and falling over the shoulders. In one bas-relief the captive king, or chief, of this people is seen brought before the king, who is placing the end of a spear, or wand, on the head of his prostrate foe in token of triumph.

In two bas-reliefs built into the walls of the southwest palace, but not originally belonging to that building, were represented the victories of the Assyrians over warriors, who wore a helmet with a curved crest, resembling in shape that in early use amongst the Greeks.*

The subjugation of several nations was recorded on the walls of Khorsabad. The captives, and tribute-bearers, were generally distinguished by skull-caps or turbans, fitting closely to the head, and apparently made of folds of linen, or some similar material. It has been conjectured that they are Jews; but, unless the inscriptions furnish some evidence of the fact, there is nothing, I think, sufficiently marked, either in the physiognomy or the dress, to identify them with that people.† Several heads from these bas-reliefs are now in the British Museum. The features may certainly be distinguished from those of the Assyrians, particularly in the shape of the nose, which is very hooked; but this is a peculiarity common to several Eastern races, and not confined to the Jew. The hair and beard are less elaborately curled; but, as it has already been observed, they may have been left unfinished by the sculptor, to mark the distinction between the conquerors and the conquered.

The head-dress of another vanquished people consists of a hood, which completely covers the head, conceals the hair, and falls over the shoulders, resembling that of the women in some of the bas-reliefs from the centre of the mound at Nimroud.

Men dressed in skins were represented amongst the conquered nations at Khorsabad. The only Asiatic people thus

* See woodcut, page 29 of this volume.

† It has been suggested that one of the names written over the besieged city in a Khorsabad bas-relief is that of Ashdod, or Azotus, against which Sargon, king of Assyria, sent Tartan. (Isaiah, xx.)

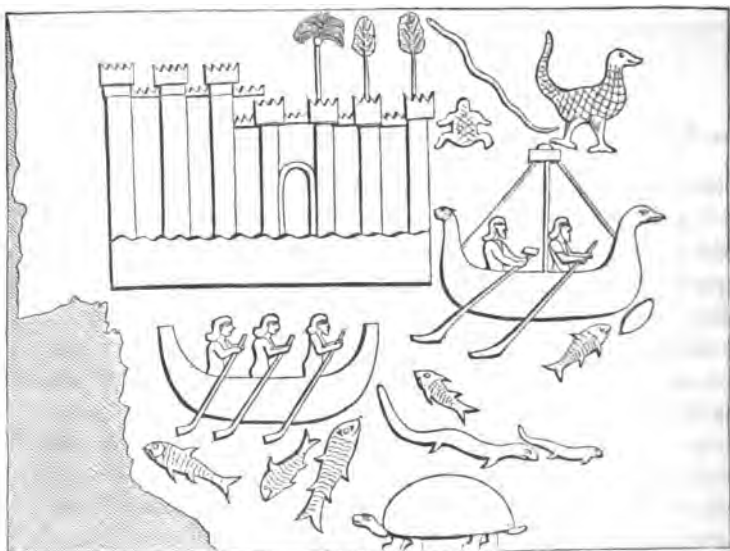

A WALLED CITY STANDING ON A RIVER OR ON THE SEA.
(Centre Palace, Nimroud.) Page 301.

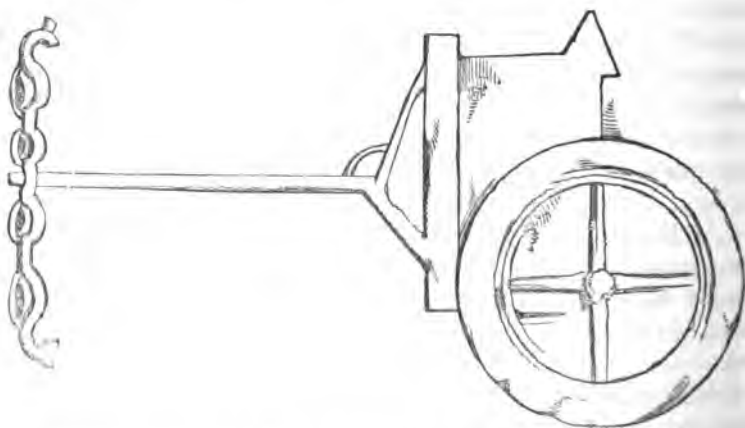

CHARIOT CARRIED AWAY BY THE ASSYRIANS, AMONGST OTHER SPOIL, FROM A
CAPTURED CITY. (Khorsabad.) Page 303.



Sacred Emblems suspended
round the Neck of the King.
(N. W. Palace, Nimroud.)
Page 338.



WINGED CIRCLE. (Pterium.)
Page 341.

clothed, according to Herodotus, in the army of Xerxes, were the Caspians and the Pactyes, who wore goat-skins. Some of the skins in the Khorsabad sculptures appear to be those of leopards; if so, the wearers may be identified with an African nation.*

Monsieur Flandin conjectures, that negroes are included amongst the conquered people of the Khorsabad bas-reliefs. In a drawing he has given to a prisoner the well-known negro features, and the short woolly hair. But the only bas-relief in which he believes the negro to occur is very much injured; and a little too much imagination may have been resorted to in its restoration.

The tribute brought by the subject nations portrayed in the Khorsabad sculptures consists chiefly of vases and bowls, earrings, bracelets, and other ornaments, all probably made of the precious metals. The conquerors, after the sacking of a city, carry away couches, tables, and chariots. The chariots differ from those of the Assyrians in the form of the yoke (which is very distinctly represented in a bas-relief), in the pole, in the four-spoked wheel, and in having an angular projection at the back.

At Kouyunjik, as I have already had occasion to observe, the conquest of a different people appears to have been recorded on the walls of each chamber. It was during the reign of one of the kings to whom I would attribute the foundation of this magnificent edifice, either of Sennacherib, Esarhaddon, or Shalmaneser, that the bounds of the empire were enlarged to an unexampled extent. Almost the whole of western Asia was overrun by the Assyrians; and their victorious armies, having subdued Syria and Judæa, and carried

* They may, however, be the skins of spotted gazelles. The skins may indicate, as on the Egyptian monuments, a division of the human race. The Egyptians ethnographically divided mankind into four branches:—1. The Rut, themselves; 2, the Naamu, or Nations, the Semitics; 3, the Nahsi, or Negroes; and 4, the Tamahu, or Northerns, who are distinguished by the ostrich-feathers on their heads, and by tunics of goat-skins.

away captive their monarchs and their inhabitants, penetrated through Egypt into Ethiopia and Lybia. Records of these conquests still exist in Syria, in Cyprus, and in various parts of Asia Minor.*

I have pointed out on what grounds we may identify with the Tyrians, or with the Phœnicians inhabiting the Syrian coasts, the maritime people represented in the sculptures. History has recorded the conquest of Tyre by Shalmaneser;† and the tablet at the Nahr-el-Kelb, near Beyrout, bears, I conjecture, either his name or that of a monarch of the same dynasty. The Kouyunjik bas-reliefs may, therefore, portray this event. In them the conquered people are distinguished by the absence of both head-dress and helmet, the hair falling loosely on the shoulders. The women have high turbans or mitres, to the back of which a veil appears to have been attached.

Amongst other conquered people were represented the inhabitants of a city, which stood between two rivers, and in the midst of groves of palm-trees. They may have been the

* I discovered the name of the Kouyunjik king on the rock-tablet at the mouth of the Nahr-el-Kelb (the Lycus), near Beyrout, of which a cast, taken by Mr. Bonomi, is in the British Museum. It is curious that, in a bas-relief found at Khor-sabad, a niche, containing a figure precisely similar to that at the Nahr-el-Kelb, was represented on the walls of a castle. I have not been able to examine, or to obtain an accurate description, of the Assyrian monument recently discovered in Cyprus, and now at Berlin. I am inclined, however, to believe that it is of the same period as the Syrian bas-reliefs.

† Josephus (lib. ix. c. 14) states that Shalmaneser warred against Tyre when Elulæus was king. According to Menander, as quoted by the Jewish historian, the Assyrian monarch subdued the whole of Phœnicia. The Tyrians having revolted, Shalmaneser attacked them with sixty vessels and eight hundred rowers, furnished by the inhabitants of the other maritime cities. The Tyrians, however, engaged this large fleet with only twelve galleys, completely dispersed it, and took five hundred men prisoners. The Assyrians then invested the city for five years, cutting off the communication of the inhabitants with the rivers and wells which furnished them with fresh water. Eusebius, quoting from Abydenus, states that Sennacherib defeated the Greek fleet on the Cilician coast. The whole passage is curious, as connecting Sennacherib with a Sardanapalus of history, and attributing to him the building of Tarsus, in the form of Babylon, with the Cydnus running through the centre.

Babylonians, and the bas-reliefs may have recorded the reconquest of that city after one of those rebellions, alluded to in history, in which it had thrown off the Assyrian yoke.* Another subdued nation had castles built on lofty mountains, and in the midst of forests. Some cities captured by the Assyrians, at this period, were built on the banks of rivers, in the midst of vineyards, and on mountains clothed with firs or pines. The fir, which does not grow, as far as I am aware, in the mountains of Kurdistan, seems to indicate a country far to the north of Assyria Proper.

On the walls of one chamber the Assyrian warriors were represented taking by assault, a city built amongst mountains, and surrounded by forests and rocks. The walls were defended by men armed with spears and bows, and carrying small square shields. They were clothed in short tunics, descending to the knee, and confined at the waist by a girdle. Their hair was gathered in a bunch at the back of the head, or was cut short. The women wore long robes, ornamented with fringes. Their hair was either confined by a fillet passing round the temples, or was completely concealed by a hood, which covered the head and lower part of the face, and fell over the shoulders. When driven away captive by the Assyrians, they carried their children with them,† and bore in their hands vases, bowls, and skins filled with water or provisions.

In the sculptures of Kouyunjik, sheep, goats, and horned cattle were frequently included amongst the spoil taken from the conquered nations. From a burning city, containing large buildings, several stories in height, the Assyrian warriors were represented hurrying away with vases, chariots, couches, beds, horses fully caparisoned, and various other objects, the nature of which I could not determine, as the bas-reliefs had been greatly injured. Women riding upon mules, and mules laden with booty, were also introduced into a procession of captives.

* Under Merodach Baladan, for instance.

† The younger children were represented seated on the mother's shoulder, and held by the leg.

Such being the conquered nations, as represented in the Nineveh sculptures, it may not be uninteresting to inquire whether the Assyrians themselves, or their enemies, can be identified with any of the races portrayed on the Egyptian monuments.

Some of the vanquished people in the most ancient bas-reliefs of Nimroud resemble, in the fillet round their heads ending in a tassel, in their general costume, and in their arms, the Sharu of the Egyptian paintings. That people, indeed, in the form of their features and in their dress, have some resemblance to the Assyrians themselves, with whom Gardner Wilkinson is inclined to identify them.* They could not, however, have been the Assyrians portrayed on the most ancient monuments of Nimroud. The high pointed helmet or cap, with lappets protecting the ears, the ear-rings and other ornaments in the form of a cross, and the cross-belt over the breast, are all peculiarities of costume marking the sculptures of Khorsabad and Kouyunjik, but never seen in the earlier sculptures. The Sharu were, moreover, armed with falchions, and short swords of a peculiar shape, which I have not met with in the Assyrian bas-reliefs.

The Khita, or Sheta, of the Egyptian inscriptions were an Asiatic people, wearing a large cap and a long loose robe with open sleeves, and capes covering the shoulders. They are sometimes represented with oblong or square shields. They fought both on foot and in chariots, which carried three persons, like those of Assyria, and they lived in walled cities.† Mr. Birch identifies them with the Chaldæans; and that they inhabited a country near Assyria Proper may be inferred, by their being generally named with Naharaina and Singara.‡ They resemble a people whose conquest by the Assyrians is

* Ancient Egyptians, vol. i. p. 375.

† Wilkinson's Ancient Egyptians, vol. i. p. 383.

‡ Menander, as quoted by Josephus, (lib. ix. c. 14,) mentions the conquest of a nation called the *Kittæi* by Elulæus, king of Tyre. They must have been a maritime people, for the Tyrians are said to have sailed against them.

recorded in the bas-reliefs of Khorsabad and Kouyunjik,* and who, like the Khita, inhabited castles, carried square or oblong shields, and wore hoods over their heads.

The Shairutana of the Egyptian monuments have many peculiarities in common with the Assyrians of the most recent bas-reliefs of Nimroud; but the helmet, ornamented with horns and surmounted by a crest, consisting of a ball on a small shaft, is not Assyrian. They carried a round shield, a long spear, a javelin, and a pointed sword; and wore a short dress, over which was a coat of mail, or a cuirass of broad metal plates overlying each other, adapted to the form of the body, and secured at the waist by a girdle. They allowed their beards to grow, and had large ear-rings. Their features were distinguished by a prominent aquiline nose, and their complexion was lighter than that of the Egyptians.† The Tokkari, or Takaru, also, bear some resemblance to a people represented in the Assyrian sculptures, both in their arms and dress, and in the shape of the carts drawn by oxen.

Mr. Birch is inclined to identify the Ruten-nu, or Lodan-nu, of the statistical tablet of Karnak with the Cappadocians, or Leuco-Syrians, inhabiting the country to the north and south of the Taurus; who, he conjectures, are also represented at Khorsabad. Their physical characteristics in the Egyptian sculptures are a light complexion, brown or red hair, and blue eyes; and they bring horses, chariots, rare woods, ivory, gloves, a bear, and gold and silver vases, with the head of Baa‡. They wore tight dresses, apparently of wool, fastened in front with a buckle, and carried objects like long gloves.‡ That the Retun inhabited a country adjoining the Assyrians may be inferred, from their being mentioned in geographical lists between Naharaina (Mesopotamia), and Singara (Sinjar). Amongst the spoils represented as brought from a conquered city at Khorsabad, is the chariot closely resembling, in its yoke

* See woodcut facing p. 285.

† Sir Gardner Wilkinson's *Ancient Egyptians*, vol. i. p. 365.

‡ *Memoir on the Statistical Tablet of Karnak*, p. 17.

and four-spoked wheels, that seen at Thebes amongst the objects of tribute of this people.*

It is singular that the name of Assyria cannot be satisfactorily identified as that of a conquered nation on any Egyptian monument.† With the exception of the statistical tablet of Karnak, in which, as it has been seen, Nineveh appears to be mentioned,‡ there is no record of any expedition undertaken by the Egyptians beyond Mesopotamia into Assyria Proper. Naharaina, and the Euphrates, appear to have been the boundaries of their conquests. Assyria may have been at that period too powerful to invite invasion; or a campaign against it, proving unsuccessful, may not have been recorded. Thus among the people beyond Syria, subdued by the Egyptians, are almost always mentioned the inhabitants of Naharaina and Singara, and the Khita, and the Ruten; and, unless either of them can be identified with the Assyrians, we must conclude that the Sinjar formed the limits of the Egyptian expeditions in this part of Asia. The Ruten and the Khita may, perhaps, be identified with some of the nations with whom the Assyrians themselves were at war; but in the Egyptian sculptures we do not find those peculiarities in the costume, and in the forms of the chariots, and horse-furniture, which would satisfactorily connect the people represented with the inhabitants of Nineveh. It can scarcely be doubted that had the Assyrian warriors of the early Nimroud bas-reliefs been amongst the Egyptian captives, these distinctions would have been carefully portrayed. Nor, it will be remembered, does the name of Babel, or Babylon, more than once occur in the great statistical tablet of Karnak; whilst Singara and Naharaina are continually included amongst the conquered nations. Neither is there any mention of the great cities situated between Nineveh and

* Wilkinson's *Ancient Egyptians*, vol. i. p. 377.

† At Medinat Haboo there appears to be, amongst other names of conquered Asiatic nations, "Atur," which Mr. Birch connects with Ataru, Aturia; but the reading is, I believe, doubtful. (*Memoir on the Statistical Tablet of Karnak*. p. 24.)

‡ See page 178.

Babylon, and in Susiana, nor the rivers flowing into the Tigris after its passage through the Taurus. These facts appear to prove that the Egyptians had not, at an early period, carried their conquests into Assyria Proper, Babylonia, or Chaldæa, although there are strong grounds for suspecting that they were not unacquainted with the inhabitants of those countries, but that, on the contrary, they had felt the influence which the Assyrians exercised over Asia.*

* I am indebted to Mr. Birch for the following note with regard to the various people mentioned in the text. "Different opinions exist as to whom the Sharu or Kharu are to be referred. They cannot be Assyrians, for in one of the hieratic papyri (Select Papyri, lxxxiv. l. 11), the writer states, 'thou hast a galley going to the Sharu,' which would apparently refer to a galley coasting along the Mediterranean, probably for the sake of wine, which in another papyrus is especially alluded to as their product. (Select Papyri, pl. xcvi. l. 1.) The earliest mention of them is in the statistical tablet of Karnak, in the reign of Thothmes III., when they supplied Egypt with bows. (Birch, Gallery, p. 88—192, and Statistical Tablet.) They are the Syri or Syrians. Osburn (Ancient Egypt. p. 57) supposes the name to be Tyre, טר, Tsur, which is nearly the same. According to Dr. Hincks (An Attempt to ascertain the Letters of the Hieroglyphic Alphabet, p. 15) it is Khelbon, Χαλβων, or Aleppo. The necklaces and ear-rings are probably in the shape of the goddess Astarte, or Ashtaroth. The name is distinct from Tyre, written in hieroglyphics 'Turu,' and from Khaleb, written with very different symbols. From their maritime position they were probably Syrians in general. The Khita were probably a Mesopotamian people. They have been conjectured to be the Scythians (Champollion, Lettres Ecrites, p. 151, 501), the Shethites or Moabites (Osburn, Ancient Egypt. p. 136), the Hittites (cf. Bunsen, Ægyptens Stelle, Buch i. S. 480), and the Cuthæans of Mesopotamia (Birch, Gallery, p. 89). For the reasons for supposing them to be the Cuthæans, Casdim, or Chaldæans, see the Statistical Tablet of Karnak, p. 22 and 23. The Shairutana are always described as a maritime people, as 'the Shairutana of the Sea.' (Champ. Mon. Egypt. pl. ccciii. No. 1.) They appear at the time of the nineteenth dynasty as allies or enemies of the Pulusatu, or Philistines. They have been conjectured to be the Sidonians (Osburn, Anc. Egypt. p. 108); and the helmet has been supposed to be surmounted by the disk and crescent of Astarte. All this is, however, doubtful, and another way of writing Sidon (not to object to the introduction of *r*), occurs in the historic papyri. Did the 'Great Lake,' or 'Sea,' refer to the Caspian? The people called by Sir Gardner Wilson Takara, are of the same race as the Philistines. There is some difficulty about the reading of this name, whether Fikaru, or Takaru, or Takalu. They have been conjectured to be the Philistine people of Ekron. (Osburn, Anc. Egypt. p. 140.) The people of Naharaina are once represented in the monuments of Egypt, in a tomb at Gournah. Their heads are bound with a simple fillet; they are

dressed in simple garments, and have long beards, resembling the other Semitic races. Their tribute is gold and silver vases. The tomb is of the age of Thothmes IV., and either represents an event of that, or of the preceding, reign. (Champ. Monum. tome ii. pl. clx.) Atur is the Egyptian word for 'river'; it suggests that Aturia and Assyria meant the 'land of the river.' The name of Assuar in the Select Papyri, as a country conquered by the Egyptians (Pl. lvii. l. 6; Hincks's Attempt, p. 46), is not certainly identified with Assyria."

CHAPTER VI.

THE monuments hitherto discovered in Assyria, furnish us with few details illustrating the private life and domestic economy of those who raised them. The bas-reliefs are mostly public records of conquests, triumphs, and great religious ceremonies. As they were placed in palaces and temples, they could, of course, but refer to national events; no others being worthy of so conspicuous a position. If any memorial of the private life of an individual were preserved, or if his peculiar profession or trade were indicated, it must have been in his own dwelling or in his tomb, as in Egypt. Hitherto only the public buildings of Assyria have been discovered, and we have consequently only the public records. If the interiors of houses and the occupations of their inmates, are represented in the bas-reliefs, they are casually introduced, to illustrate or to convey more fully the meaning of the general subject. Thus, within the walls of castles belonging to the Assyrians, or captured by them, are seen buildings and tents. The inhabitants are slaying sheep, and engaged in domestic occupations, seated and conversing together, feeding their horses, and preparing their couches. But these details are all made subservient to the main action, which is the siege or triumph.*

With such scanty materials at our command, we can

* In the Assyrian sculptures attendants are frequently introduced carrying vessels and skins, probably containing provisions. It may be observed that the skins are tied precisely as at this day—the two extremities being fastened by the opposite ends of one string.

scarcely venture to form any conjecture as to the manners and private life of the Assyrians. The subject must be deferred until further discoveries have supplied us with additional information.

From casual notices in the Bible and in ancient history, we learn that the Assyrians, as well as those who succeeded them in the empire of Asia, were fond of public entertainments and festivities, and that they displayed on such occasions the greatest luxury and magnificence. The Assyrian king, called Nabuchodonosor in the book of Judith, on returning from his victorious expedition against Arphaxad, feasted with his whole army for one hundred and twenty days. The same is related by the Greek authors of Sardanapalus, after his great victory over the combined armies of the Medes. The book of Esther describes the splendor of the festivals given by the Babylonian king. The princes and nobles of his vast dominions were feasted for one hundred and eighty days; and for one week all the people of Susa assembled in the gardens of his palace, and were served in vessels of gold. The richest tapestries adorned the halls and tents, and the most costly couches were prepared for the guests.* Wine was served in abundance, and women, including even the wives and concubines of the monarch, were frequently present to add to the magnificence of the scene. According to Quintus Curtius, not only did hired female performers exhibit on these occasions, but the wives and daughters of the nobles, forgetting their modesty, danced before the guests, divesting themselves even of their garments.† Wine was drunk immoderately. When Babylon was taken by the Persians, the inhabitants were celebrating one of their great festivals, and even the guards were intoxicated.‡ The Babylonian king, ignorant of the approaching fate of his capi-

* Esther, i.; Daniel, v.

† That it was subsequently the custom of the Persians to introduce their wives and concubines at their public banquets, is shown by the anecdote of Amyntas and the Persian ambassadors, related by Herodotus. (Lib. v. c. 18.)

‡ Xenophon, Cyrop. vii. 5.; Herod. i. i. c. 191.

tal, and surrounded by one thousand of his princes and nobles, and by his wives and concubines, drank out of the golden vessels that had been carried away from the Jewish temple.* On the walls of the palace at Khorsabad was a bas-relief representing a public feast, probably in celebration of a victory. Men were seen seated on high chairs with drinking-cups in their hands; whilst attendants were bringing in bowls, goblets, and various fruits and viands, for the banquet. At Nimroud part of a similar bas-relief was discovered.

Music was not wanting on these occasions. It is probable that the Assyrians, like the Egyptians, had various musical instruments; only one kind, however, is represented in the sculptures. It is in the shape of a triangle, is held between the left arm and the side, and appears to have been suspended from the neck. The strings, nine or ten in number, are stretched between a flat board and an upright bar through which they pass. Tassels are appended to the ends of the strings, and the bar itself is generally surmounted by a small hand, probably of metal or ivory. The instrument was struck with a plectrum held in the right hand: the left appears to have been used either to pull the strings, or to produce notes by pressure. Like the Egyptian harp, it had no cross-piece between the upright bar and the flat board or base; it is difficult, therefore, to understand how the strings could have been sufficiently tightened to produce notes.†

In describing the dress of the Assyrians, I have had occasion to allude to their skill in the manufacture of linen and woollen stuffs, which were dyed, and embroidered not only with a variety of beautiful ornaments, but with groups of human figures and animals. Of all Asiatic nations, the Babylonians

* Daniel, v. 2.

† There is a representation of this musical instrument in the bas-relief of the king standing over the crouching lion, now in the British Museum. There are also several examples of it in my "Monuments of Nineveh." The god which Mr. Birch now conjectures to be Beal (Gallery, fig. 80), is represented at Talmis playing on a triangular lyre. (Rosellini, M. C., Teste, tome iii. p. 19. tav. ann.)

were most noted for the weaving of cloth of divers colors. In these stuffs gold threads were introduced into the woof of many hues.* Amongst those who traded in "blue clothes and embroidered work" with Tyre, were the merchants of Aeshur or Assyria;† and that the garments of Babylon were brought into Syria, and greatly esteemed at a very early period, we learn from their being classed amongst the most precious articles of spoil, even with gold, in the time of Joshua.‡ They formed, perhaps, "the dyed attire and embroidered work" so frequently mentioned in the Scriptures as the garments of princes, and the most costly gifts of kings. The ornaments and figures upon them may either have been dyed, worked in the loom, or embroidered with the needle, like "the prey of divers colors of needle-work, of divers colors of needle-work on both sides."§

The cotton manufactures of Babylon were as remarkable for brilliancy of color as fineness of texture, and Pliny attributes the invention of cotton weaving to Semiramis.|| The silken robes of Assyria were equally esteemed. The looms of Babylon maintained their celebrity long after the fall of the Assyrian empire—even to the time of the Roman supremacy.¶

The carpets of Babylon were no less prized than her other manufactures. Like the Assyrian robes, they appear to have been embroidered with figures of animals and flowers. A purple carpet covered the tomb of Cyrus; and on the bed upon

* Pliny, viii. 48.

† Ezekiel, xxvii. 24.

‡ Joshua, vii. 21. Achan confesses to Joshua that "when he saw among the spoils a goodly Babylonish garment, and two hundred shekels of silver, and a wedge of gold of fifty shekels weight, he coveted, and took them."

§ Judges, v. 30.

|| C. vii. p. 417.

¶ According to Plutarch, Cato, receiving as a legacy a Babylonish garment, sold it, because too costly for a citizen to wear. Arech, on the Euphrates, was long celebrated for its looms. Some Babylonian curtains and draperies were sold, according to Pliny, for nearly £7000.

which the body was placed, were Babylonian garments, carpets, and purple drapery.*

These manufactures probably formed one of the principal branches of trade of "this land of traffic and city of merchants."† The Babylonians and Assyrians carried on a considerable commerce with India; and the costly produce of that peninsula was conveyed through the Babylonian territories to the most distant regions of Syria, from whence it was diffused over western Europe and Asia Minor.‡

The Assyrians were no less celebrated for their skill in working metals than for their embroideries.§—Their mountains furnished a variety of minerals—silver, iron, copper, and lead, and perhaps even gold. Iron, the most useful of all metals, was the one which most abounded, and which could be most easily procured, as soon as the process of extracting it from the ore was known. I have observed that it is found in great quantities scattered on the sides of mountains, three or

* Arrian, vi. 29. The carpets of Babylon, worked with wonderful animals, are described by Athenæus, v. p. 197. From Persia they passed into Greece. (*Æschyl. Agam.* l. 898, 899, 913, 925; *Aristophanes, Ranæ*, l. 935; *Aristot. Phys. Ausc.* iv.; *Menander, apud Athen.* xi. p. 484, 500.) The Parthians appear to have preserved the art of these manufactures (*Pliny, l. viii. c. 73*), for which the modern Persians and the inhabitants of the Kurdish mountains are still eminently distinguished.

† Ezekiel, xvii. 4.

‡ Heeren has fully and ably described the nature and extent of the commerce of the Babylonians in his *Essays on the Policy and Commerce of the Ancients*. The commercial route from India to Syria was first to the Sabæi and Dedan on the southern and eastern coast of Arabia. (*Isaiah, lx. 6*; *Ezekiel, xxvii. 15 and 20.*) It then passed through the Gerrhæi. (*Diod. iii. 41*; *Strabo, xv.*) North of the Dedan, the route lay through Thema (*Isaiah, xxi. 14*; *Job, vi. 19*; *Jeremiah, xxv. 23*; *xlix. 7, 8*; *Ezekiel, xxv. 13*); from thence to the land of Kedar. (*Isaiah, lx. 7.*)

§ It was the custom of the Babylonians, as we learn from *Jeremiah, xxiv. 1*, to carry away the smiths and carpenters of a conquered nation. It is probable, therefore, that whilst the Assyrians themselves were skilful in various arts, they had also collected together during their conquests expert workmen from all parts of Asia.

four days' journey from Mosul.* Amongst the objects of tribute enumerated in the statistical tablet of Karnak, iron is mentioned as brought to the Egyptians almost exclusively by the inhabitants either of Assyria Proper, or of the countries immediately adjacent—by the Tahai, the Ruten-nu, and the Asi. It was generally exported in the form of bricks or pigs, but also occasionally in the ore. The same nations, particularly the Tahai, offered gold, silver, tin (?), copper, brass, lead, and antimony (?). These metals were not only brought in the rough state, or, if gold and silver, in rings, but even manufactured into vases of beautiful form. Mr. Birch remarks: "The silver vases of the Tahai are a remarkable tribute, as they show an excellence in working metals among these people; indeed, the art of toreutic work in Asia influenced so largely even the Greek world at a later period, as to rival and gradually supersede the fictile painted vases of the Greeks."† And he then mentions "the offerings of vases of gold and silver, with handles, and feet, and covers in the shape of animals, such as the bull and gazelle (or? wild goat), kneeling Asiatics, the heads of lions, goats, and even of the god Baal." All these are pure Assyrian emblems. The vase in the form of a lion's head, probably similar to that represented in the sculptures of Khorsabad, is particularly alluded to amongst the offerings of the Tahai. The tribute obtained by the Egyptians from Naharaina, or Mesopotamia, consisted of vases of gold, silver, and copper, and precious stones; and vases of gold, silver, and brass were the presents brought by the prince of northern Syria to David.‡

Gold is not now, I believe, known to exist in the mountains of Kurdistan. As, both according to sacred and profane authors, it was collected in such extraordinary quantities in Nineveh and Babylon, and as it is generally included in the

* Vol. I. p. 190.

† Observations on the Statistical Tablet of Karnak, p. 33.

‡ 2 Samuel, viii. 10, and 1 Chron. xviii. 10.

Egyptian inscriptions amongst metals brought from that part of Asia, it is to be presumed that mines of it were once worked within the Assyrian dominions.* It was used by the Assyrians, as I have already mentioned, in their architectural ornaments, bricks and tiles of gold and silver being even placed in the exterior walls of their palaces.† That they were at a very early period acquainted with the art of gilding is proved by the remains of very thin gold leaf, found not only on the ivories and on bricks, but even under the great throne or altar in the northwest palace, where it must have been deposited during the building of the edifice.‡

Silver is found in the mountains of Kurdistan, and mines of it are still worked by the Turkish government near the frontiers of ancient Assyria, and in Armenia. It is very probable that others exist in a country whose mineral riches have not been explored.

* Sardanapalus is said to have placed one hundred and fifty golden beds, and as many tables of the same metal, on his funeral pile, besides gold and silver vases and ornaments in enormous quantities, and purple and many-colored raiments. (Athenæus, lib. xii.) When Nineveh was taken, it contained, according to some absurd traditions, £25,000,000,000 sterling in gold! The spoiler might well have exclaimed, "Take ye the gold, take ye the silver—the riches of Nineveh are inexhaustible—her vases and precious furniture are infinite." (Nahum, ii. 9.) That this precious metal, however, was most plentiful, we can scarcely doubt. The statue of solid gold raised by Nebuchadnezzar in the plain of Dura was threecore cubits high, and six cubits broad. (Daniel, iii. 1.) Herodotus and Diodorus describe the statues of this metal in the temple of Belus, at Babylon. The base of the table, the seat of the throne, and an altar on which sacrifices were offered, were all of the purest gold. Xerxes carried away the golden statue of the god, twelve cubits in height, which his father Darius had not ventured to seize. (Herod. l. i. c. 183.) According to Diodorus, the value of the gold taken from the temple of Belus alone by Xerxes amounted to above 7350 Attic talents, or £21,000,000 sterling money!

† Thus the walls of Ecbatana were partly plated with gold and silver. (Herod. l. i. c. 98.)

‡ Gold and silver "spread into plates" are mentioned in Jeremiah amongst the objects of trade brought from Uphaz and Tarshish (ch. x. ver. 9); and Solomon's throne was partly overlaid with gold; as was also the inside of his temple (1 Kings, vi. 22, and x. 18.)

Although the precious metals were known at a very early period, even Abraham, a dweller in tents, being rich in gold and silver,* no coins have been discovered amongst Assyrian ruins, nor is there any thing in the sculptures to show that the Assyrians were acquainted with money, as in Egypt. Metals in their rough state, or in bars or rings, may have been passed by weight, or, if precious, in ring-ingots, or as gold dust, in exchange for merchandise, and in other transactions, but not as stamped coins or tokens.† It is remarkable, that no coin has yet been discovered in Egyptian ruins.‡

Copper mines, worked at a very remote period, probably by the Assyrians themselves, still exist in the mountains within the confines of Assyria.§ This metal appears to have been extensively used by the Assyrians, both for ornaments, and in the construction of weapons and tools. It was inlaid into their iron helmets, and formed part of their armor. Daggers and the heads of arrows were frequently made of it, mixed, it would appear, with a certain quantity of iron, and hardened, as in Egypt, by an alloy of tin. The tools of the sculptor were probably of some such combination; but as the Egyptians appear to have been acquainted, at a very early period, with steel, and to have used it, as well as bronze, in sculpturing stone, marble, and granite, it may be inferred that the Assyrians were not ignorant of this useful form of iron. The soft limestone of their monuments would not, however, like the granite of Egypt, require a very highly tempered instrument. But the black basalt is hard, offering considerable resistance to

* Genesis, xiii. 2.

† The money mentioned in the Bible is always passed by weight. (Genesis, xliii. 21.)

‡ The earliest mention in authentic history of a coin current in the Persian dominions is in Herod. lib. iv. c. 166; the same author declaring (lib. i. c. 94) that the Lydians were the first people who coined money. It was issued by Darius Hystaspes, and called after him "the Daric." It was long afterwards celebrated for its purity, and gave its name to all gold pieces subsequently coined in Persia, even by kings of the Macedonian race.

§ Vol. I. p. 190.

the tools of the sculptor ; and we find that the Assyrian statues in this material are less carefully finished than the bas-reliefs of alabaster.

Antimony is, I believe, found in the Kurdish mountains ; but I am not aware of the existence of tin in any part of Assyria. Still the Assyrians and the adjoining nations must have obtained this metal from their own dominions, or from some country to the east of them, as it is mentioned amongst the objects of tribute brought to the Egyptians from that part of Asia. It would scarcely have been procured, merely for the purpose of an offering, from the Phœnicians, who were so much nearer Egypt.

The Assyrians were equally skilled in working and casting metals. Amongst the copper figures from Nimroud, I must particularly mention the lions in solid metal found under the fallen bull in the great hall, which are of great beauty, almost rivalling the bronzes of Greece ; and three hollow lions' paws, which apparently formed the feet of a throne or couch.

I have already had occasion to speak of their dexterity in carving ivory, and have described the beautiful ornaments in that material discovered at Nimroud. Although the elephant was not an inhabitant of Assyria, but was probably brought from India, its tusks appear to have been an article of trade between the Assyrians and the nations to the westward. The workmen, too, of Assyria were employed by foreign nations as carvers in ivory ; and we find the company of the Ashurites or Assyrians, making the benches of that material in the Tyrian galleys.* The Assyrians had already extensively used it in the construction of their palaces ; and it was from them, perhaps, that the Jews adopted it in the decoration of their

* Ezekiel, xxvii. 6. It is possible that some tribe, and not the Assyrians, is meant. Mr. Birch conjectures that the Phœnicians, who appear to have supplied the Greeks with ivory ornaments at a very early period, may have chiefly derived the elephant's tusk from an indirect communication with India and Bactria through Assyria.

palaces and furniture.* The human head and limbs carved in ivory, discovered at Nimroud, probably belonged to an entire figure, the body of which may have been of wood or metal, like the Chryselephantine statues of the Greeks, which were of wood inlaid with gold and ivory. The Assyrians were acquainted with the art of inlaying. Blue opaque glass and other substances of various colors are let into the ivory tablets from Nimroud.

They had also acquired the art of making glass.† Several small bottles or vases of elegant shape, in this material, were found at Nimroud and Kouyunjik. One bears the name of the Khorsabad king; and to none of the specimens discovered can we with certainty attribute a higher antiquity than the time of that monarch; although some fragments in the shape of a dagger from a hall of the most ancient palace of Nimroud may possibly be more ancient. The gems and cylinders still frequently found in ruins prove that the Assyrians were very skilful in engraving on stone. Many of their seals are most delicately and minutely ornamented with various sacred devices and with the forms of animals. Those of the Babylonians are mentioned by Herodotus, who also describes the heads of the walking-sticks in the shape of an apple, a rose, a lily, or an eagle.‡ These ornaments were probably carved in ivory or in precious stones.

Herodotus alludes to the extreme fertility of Assyria, and to its rich harvests of corn, the seed producing, according to his account, two or three hundred-fold. The blades of wheat and barley grew to full four fingers in breadth; and, such was

* Ahab had an ivory house. (1 Kings, xxii. 39.) Ivory palaces are mentioned in Psalm xlv. 8. And compare Amos, iii. 15. Solomon made a throne of ivory. (1 Kings, x. 18.) Beds of ivory are spoken of in Amos (vi. 4). Mr. Birch has collected, in his *Memoir on the Nimroud Ivories*, (Trans. of R. Soc. of Lit., New Series,) various instances of the early use of ivory amongst the Assyrians, Egyptians and Greeks.

† Pliny attributes the invention of glass to the Phœnicians.

‡ L. i. c. 195.

the general richness of Babylonia, that it supplied the Persian king and his vast army with subsistence for four months in the year, whilst the rest of the Persian dominions furnished provisions for the other eight.* This, it must be remembered, was when the country had lost its independence, and had been reduced to a mere province. I have already described the mode of irrigation by artificial canals derived from the Tigris and Euphrates, intersecting the whole of the lower part of Mesopotamia, and the country in the neighborhood of the rivers in the upper.† The Assyrians also used machines for raising water from the river, or from the canals, when it could not be led into the fields through common conduits. They were generally obliged to have recourse to this artificial mode of irrigation, as the banks of the rivers, and consequently those of the canals, were high above the level of the water, except during the spring. At that season of the year the streams, swollen by the melting of the snows in the Armenian hills, or by violent rains, overflowed their beds.

The only representation of an agricultural instrument yet found in Assyria or Babylonia is that of a plough, on a black stone from the ruins opposite Mosul.‡ From the form of the arrow-headed characters in the inscription, this appears to be a Babylonian relic. The plough somewhat resembles in shape that now in common use. On the same tablet is an altar or low building, before which stands a priest, apparently performing some religious ceremony; near him are the sacred tree, a bull, a heap of corn or a hill, a palm-tree, and a square instrument with a small circle or wheel at each corner, the nature of which I am unable to determine.

Sesame, millet, and corn, formed anciently, as they still do, the principal agricultural produce of Assyria. Herodotus, who had visited this fruitful country, says that he dares not mention the height to which the sesame and millet grew.§ The only

* Herod. l. i. c. 192.

† Vol. l. p. 267.

‡ Now in the possession of the Earl of Aberdeen.

§ Lib. i. c. 193.

oil used in the country, according to the historian, was extracted from sesame; and such is now the case, although the olive-tree is cultivated at the foot of the Kurdish hills.

The palm-tree, whilst growing in the greatest abundance within the ancient limits of the Assyrian empire, does not now produce fruit further north than the junction of the Lesser Zab with the Tigris. It is not, indeed, found on the banks of the latter river more than sixty miles above Baghdad; but this is chiefly owing to the absence of cultivation and settled habitations. It is raised inland as far north as the small town of Taza Kurmali, which takes its name, "the place of fresh dates," from the ripe fruit being there first met with on the road from Constantinople. A line drawn due west from this place to the Mediterranean would, I think, give the limits of the growth of the fruit-producing palm. The unproductive tree will grow and will attain a considerable size much further north, even on the southern coast of Asia Minor, and in the south of Italy and Dalmatia. That the fruit was exported in large quantities from the Babylonian plains, as it now is, as an article of commerce, may be inferred from palm wine, or spirits extracted from the date, being mentioned by Herodotus as the principal cargo brought by rafts to Babylon from Armenia. We find, also, what is probably palm wine included in the statistical table of Karnak amongst the tribute offered to the Egyptians by the Tahai.

As lofty mountains rise abruptly from the plains, opposite degrees of temperature mark the climate of Assyria. The soil being naturally rich, its produce is consequently as varied as plentiful. The plains watered by the rivers are parched by a heat almost rivalling that of the torrid zone. Aromatic herbs, yielding perfumes celebrated by the poets, indigo, opium, and the sugar-cane,* besides corn and grain of various kinds, and

* Indigo and opium are still cultivated to the south of Baghdad. The sugar-canes, which, in the time of the Persian kings, covered the banks of the rivers of Susiana, have now disappeared; and this plant is no longer cultivated to any extent to the east of the Euphrates.

cotton and flax in abundance, were raised in this region. In the cooler temperature of the hills, the mulberry afforded sustenance to the silk-worm,* and many kinds of fruit trees flourished in the valleys. When Herodotus says that the Assyrians did not cultivate the vine, the olive, or the fig, he must allude to the inhabitants of the plains. The vine is represented in the sculptures; and that the Assyrians not only enjoyed the various luxuries which those trees afford, but possessed the trees themselves, we learn from their own general, Rabshakeh, who described his country to the Jews as a "land of corn and wine, a land of bread and vineyards, a land of olive oil and of honey."† Amongst the objects of tribute brought to the Egyptians from the Tahai, and from Naharaina, are corn, bread, palm wine, wine, honey, incense, and conserve of dates.‡

The domestic animals of the ancient Assyrians were probably such as are still found in the country. On the monuments are seen sheep, goats, oxen, horses, mules, and camels. In a bas-relief from the centre of the Nimroud mound, there appeared to be the figure of a dog standing near a tent; but the sculpture was much injured. I have not found any other representation of this useful domestic animal, although hunting scenes were portrayed on the walls of Khorsabad; and we learn from Herodotus§ that during the Persian occupation, the number of Indian dogs kept in the province of Babylon for the use of the governor was so great, that four cities were exempted from taxes for maintaining them. Neither is the ass represented in the sculptures; although Herodotus mentions it amongst the domestic animals of the country, and Xenophon amongst the wild.|| The mules of the Kouyunjik

* Pliny particularly mentions silk amongst the produce of Assyria. (Lib. ii. c. 25.)

† 2 Kings, xviii 32.

‡ In the hieratic papyri (Select Papyri, pl. xvi. 15), a drink called nekfitara or nekftar, a word which resembles the celebrated nectar, is said to come from Saenkar, or Sinjar: it is mentioned with other liquids or cosmetics from the Arasa, the Khita, the Amaur, the Tachisa, and Naharaina.

§ Lib. i. c. 192. The dog is occasionally represented on cylinders.

|| Chariots drawn by asses are mentioned in Isaiah (xxi. 7).

bas-reliefs appear to belong to a conquered people ; in a procession of captives, women are seen riding on them, and they carry the spoil. They are correctly delineated, and may at once be distinguished from the horse.

The sheep represented in the bas-reliefs are of two kinds. One has a large broad tail, and is still found in the country. The tail of the other is smaller. As they are amongst the spoil, and consequently belonged to the enemies of the Assyrians, they may be the sheep of Arabia which excited the wonder of Herodotus. "One," says he, "has a large tail, not less than three cubits in length, which, if suffered to trail, would ulcerate. The shepherds, therefore, made little carts to support it. The other has a tail nearly a cubit in breadth."*

The goats have long spiral horns. The oxen are evidently of two kinds, one distinguished by horns curved towards the back of the head, the other having horns projecting in front. It is possible that this distinction marks the buffalo and common ox. Of the Assyrian horses I have already had occasion to speak. Although the form of the camel is somewhat exaggerated, the character of the animal is faithfully portrayed. On the obelisk is the two-humped or Bactrian camel ; but it evidently came from afar, and was not a native of Assyria Proper. The one-humped camel, as it has been seen, was ridden, even in war, by a people conquered by the Assyrians ; and as a woman is represented mounted upon one, it may be conjectured that it was commonly used as a beast of burden. When brought as tribute, collars and ornaments, probably of dyed wool, were hung round its neck.† When mounted, it appears to have been guided by a simple halter

* Lib. iii. c. 113. This broad tail is the רָחֵב־זָנָב mentioned in Leviticus, iii. 9 ; vii. 3, &c., translated "the rump" in our version. The sheep is the *ovis laticauda*, Lin. (Gesenius, Heb. Diet.)

† The chains and ornaments, like those worn on the camels' necks, are mentioned in Judges, viii. 21 and 26.

or head-stall, passing round the centre of the head, like that of the modern Arab.*

The wild animals represented in the sculptures are either natives of Assyria, or of foreign countries. Amongst the former we have the lion, the wild bull, the stag, the gazelle, the ibex, and the hare.

The lion, as I have observed,† is now rarely found on the banks of the Tigris as far north as Mosul, or even above Baghdad. That it was originally an inhabitant of the country, there can be no doubt. From the earliest period it was considered the noblest of game, and was included amongst the wild beasts preserved in the paradises, or parks, attached to the royal palaces. On the monuments of Nineveh, the triumphs of the king over this formidable animal are deemed no less worthy of record than his victories over his enemies. History and tradition, too, have celebrated the prowess of Ninus and Semiramis in their encounters with the lion; and paintings, representing these feats, adorned the palaces of Babylon. The Assyrian sculptor evidently delighted in such subjects, in which, indeed, his skill could be eminently displayed. He had carefully studied the animal, and whilst he excelled in the delineation of its form, he portrayed its action and expression with wonderful spirit, faithfully preserving the character of the ani-

* That camels formed a principal part of the flocks of the people anciently inhabiting Assyria and Chaldæa, we have ample proof in the Bible (Genesis, xxiv. 19); they were possessed by Abraham (Genesis, xii. 16), and by Jacob (Genesis, xxx. 43); they were used as beasts of burden (Genesis, xxxi. 34, and 1 Samuel, xxx. 17); also, as to this day, by couriers and for posts (Esther, viii. 10 and 14). The fleet dromedary was not a distinct animal, but probably a camel specially trained, as the *hajin* of the modern Arabs. I have travelled on those used in the Arabian desert, and their speed and powers of endurance are both equally surprising. Herodotus mentions that the camels used by a certain tribe of Indians were as swift as horses. (Lib. iii. v. 102.) That camels were even sometimes harnessed in chariots may, perhaps, be inferred from Isaiah, xxi. 7. The earliest mention of the camel in Egyptian monuments is in the time of the nineteenth dynasty. It is not represented on any monument hitherto discovered.

† P. 44.

mal, when springing with fury upon its assailant, or dying, pierced with arrows, at his feet.*

The lion of the sculptures is furnished with a long and bushy mane. It has been doubted whether the animal which still inhabits the country has this noble appendage; but I have seen more than one on the banks of the Karoon provided with it. There is a peculiarity in the Asiatic lion which has not escaped the notice of the sculptor—the claw at the extremity of the tail. This claw was not unknown to ancient naturalists. The first mention of it is found, I believe, in the Commentary of Didymus of Alexandria on the Iliad. In modern times its existence was denied, and has only been established within a few years. It is still, I believe, considered to be a mere casual excrescence, and is not met with in all specimens of the animal.†

The wild bull, from its frequent representation in the bas-reliefs, appears to have been considered scarcely less formidable and noble game than the lion. The king is frequently seen contending with it, and warriors pursue it both on horseback and on foot. In the embroideries on the garments of the principal figures it is introduced, both in hunting scenes and in groups, which appear to have a mythic or symbolical meaning. I was at one time inclined to think that the bull of the sculptures might represent the unicorn or *raim* so often alluded to in the Scriptures, as an animal renowned for its strength and ferocity, and typical of power and might.‡ But the unicorn

* The skill of the Assyrian sculptor in delineating the lion, is particularly shown in the bas-relief in the British Museum. The lion is not represented in the Assyrian, as in the Egyptian, sculptures, tamed and following the king, or trained to the chase.

† Proceedings of the Council of the Zoological Society for 1832, p. 146. Captain W. Smee, in a paper on the Maneless Lion of Guzerat (Trans. of the Zool. Soc. vol. i. p. 169), observes, "in this tuft (of the tail) there existed, subsequently to its arrival in England, in the oldest of my lions, a short horny claw or nail, similar in form to, but somewhat larger in size, than the one described by Mr. Woods."

‡ Gesenius (Lex. in voce) gives the signification of wild buffalo to the *רַיִם*, —the monoceros, rhinoceros, and unicornis of the Septuagint.

of the Scriptures is now, I believe, generally identified with a large and fierce antelope, or oryx, inhabiting Arabia and Egypt. Professor Migliarini of Florence informs me that the word *raim* itself occurs in hieroglyphics over a figure of this antelope, in an Egyptian sculpture; and he conjectures that the Jews derived a knowledge of the animal, as well as its name, from the Egyptians. The bull of the bas-reliefs of Nimroud is evidently a wild animal, which inhabited Mesopotamia or Assyria. Its form is too faithfully delineated to permit of the supposition that it is an antelope. It is distinguished from the domestic ox by a number of small marks covering the body, and probably intended to denote long and shaggy hair. It is represented with one horn, as the horses have frequently only two legs or one ear, because the Assyrian sculptor did not attempt to give both in a side view of the animal.

As mention is also made in the Bible of the wild ox,* it is probable that at some ancient period this animal was an inhabitant of Assyria, or of the adjacent countries, although it has long since become extinct. Had it been found in the plains of Mesopotamia in the time of Xenophon, he would probably have described it when speaking of the animals of that province. As it is only seen in the oldest monuments of Nimroud, and not in those of Khorsabad or Kouyunjik, it is possible that, when the country became more thickly peopled in the latter period of the Assyrian empire, the wild ox disappeared.

On the walls of Khorsabad was represented a hunting scene, in which hares and partridges were introduced as objects of the chase. Both still abound in the country.

The ibex, or wild goat, is an inhabitant of the mountains

* Deut. xiv. 5. The wild ox is included amongst the animals whose flesh may be eaten by the Jews; and the "wild bull in a net" is also alluded to in Isaiah, li. 20. The Hebrew word is rendered "wild bull" in the Targums, and "oryx" (אֲרִיָּס) in the Vulgate; some, however, believe the animal meant, to be a kind of antelope. (Gesenius, Lex. in voce.)

of Kurdistan.* The stag is found in the forests, and the plains are covered with innumerable flocks of gazelles. More than one species of wild sheep, only recently known to European naturalists, haunt the higher ranges of the Assyrian mountains. Several of these animals are portrayed in the sculptures. The ibex was evidently a sacred animal, as it is carried by the winged figures, and is frequently introduced as an ornament.† A stag, also borne by a winged priest or divinity, was spotted like the fallow deer of our parks.

The frequent representation of hunting scenes in Assyrian sculptures is a proof of the high estimation in which the chase was held by the people. A conqueror and the founder of an empire was, at the same time, a great hunter. His courage, wisdom, and dexterity were as much shown in encounters with wild beasts as in martial exploits; he rendered equal services to his subjects whether he cleared the country of wild beasts or repulsed an enemy. The scriptural Nimrod, who laid the foundation of the Assyrian empire, was "a mighty hunter before the Lord;" and the Ninus of history and tradition; the builder of Nineveh, and the greatest of the Assyrian kings, was as renowned for his encounters with the lion and leopard, as for his triumphs over warlike nations. We have seen that the Babylonians, as well as the Assyrians, ornamented the walls of their temples and palaces with pictures and sculptures representing the chase; and that similar subjects were introduced, even in the embroideries on their garments.‡ The Assyrians were probably also the inventors of the parks, or paradises, which were afterwards maintained with so much sumptuousness by the Persian kings, of the Achæmenian and Sassanian dynasties.§ In these spacious pre-

* It is possible that the animal I have assumed to be the ibex is sometimes the gazelle.

† See p. 296 of this volume.

‡ Ammianus Narcell. lib. xxvi. c. 6; Diod. Siculus, lib. ii.; Athen. lib. xii. c. 9.

§ Xenophon, Cyr. lib. i. c. 3; Quint. Curt. lib. vii. and viii. These paradises were stocked, not only with game of every kind, but with various trees, shrubs, and

serves various kinds of wild animals were continually kept for the diversion of the king, and for those who were privileged to join with him in the chase. They contained lions, tigers, wild boars, antelopes, and many varieties of birds. As amongst the Persians, the Assyrian youths were probably trained to hunting at an early age. Xenophon gives an interesting account of the hunting expeditions of the Persians in the time of Cyrus. The king was accompanied by half his guard, each man being furnished with a bow, quiver, sword, shield, and two javelins—armed, indeed, as if he were going to war. That such was also the practice amongst the Assyrians is shown by the Nimroud bas-reliefs, in which the king is always represented as accompanied in the chase by warriors fully equipped; hunting being, as Xenophon declares, the truest method of practising all such things as relate to war.*

On the obelisk, as I have already mentioned, are representations of several animals, evidently brought from distant countries, and presented to the Assyrian king as objects of tribute. The presence of the two-humped camel proves that they came from the East, and not from Africa. This animal is a native of Bactria, or of the great steppes inhabited by the Tartar tribes. It is unknown to the Arabs, and is rarely seen to the west of Persia, except amongst a few isolated families of Turcomans, who now reside in the north of Syria, and who probably brought this beast of burden from the northeast, when they first emigrated.

The small ears of the elephant, on the same obelisk, show that the animal is of the Indian, and not of the African species.†

On Egyptian monuments, the elephant is seen, amongst other animals, brought as tribute by an Asiatic, though not

plants; and were watered by numerous artificial streams. The Persian word has passed into various languages, and is used for the first abode of man before his fall, as well as for the state of eternal happiness.

* *Cyrop.* lib. i. c. 2.

† *Elephas Indicus.*

an Indian people.* It was probably obtained by them from the eastward; for there is no record of the elephant being indigenous in any part of Asia west of the Indus. Although it appeared in the Persian armies, and might even have been pastured long previously in the rich plains of Mesopotamia, it originally came from the Indian dominions of the great king. Had it been used in war by the Assyrians, it would doubtless have been so represented in the sculptures.†

The presence of the rhinoceros on the obelisk further points to the Indian origin of the accompanying animals. It is in several respects incorrectly delineated, the sculptor having given it hoofs, a mane on the neck, and long hair, which appears to have been artificially curled like that of the sacred bull. Still the general form of the animal, and the shape and position of the horn, clearly identify it with the Indian rhinoceros.‡ Specimens of this animal were probably rare in Assyria, and the sculptor may have drawn it from recollection or only from the description of those who had seen it. This is the earliest representation of the rhinoceros with which we are acquainted.

The two animals accompanying the rhinoceros are probably an Indian bull, and a kind of antelope. The bull has a collar ornamented with tassels, round its neck, and may have been a sacred animal. The antelope, from its size and the shape of its horns, may perhaps be identified with the Indian chikara;§ although the thickness of the limbs rather denotes a species of wild goat.

The sculptor has evidently indicated, by certain peculiarities, four distinct species of monkeys or apes. Immediately

* Sir Gardner Wilkinson's *Ancient Egyptians*, vol. v. page 176; vol. i. pl. iv.

† The elephant has not been found represented as a beast of burden on the monuments of Egypt. The only African nation who appear to have used it in their wars were the Carthaginians.

‡ *Rhinoceros unicornis*.

§ *Antelope Bennettii*. I had once conjectured it to be the nylgau of the Indian peninsula.

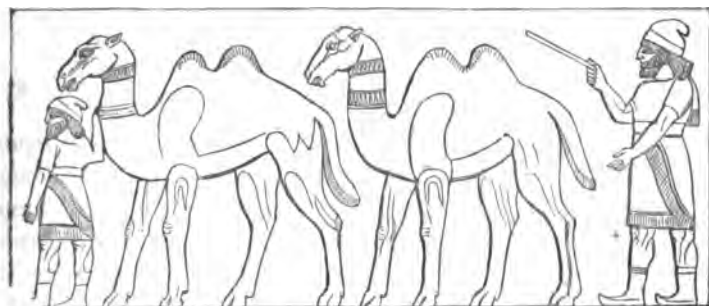

BACTRIAN OR TWO-HUMPED CAMELS. (Obelisk, Nimroud.) Page 320.



Elephant, the Ouran Outan (?), the Hounumun or small Indian Monkey (?). (Obelisk, Nimroud.) Page 330.



The Bull, the Rhinoceros, and the Chickara or large Indian Antelope (?). (Obelisk, Nimroud.) Page 331.



The Bruh or great Indian Monkey (?), and the Wanderoo or Maned Ape (?). (Obelisk, Nimroud.) Page 331.

NEW YORK
CITY

behind the elephant is a man leading a large monkey without a tail, which, if from India, can only be identified with the ouran outan, no other monkey found in that country being so distinguished.* A man follows with two smaller monkeys, one raising itself on its hind legs, the other sitting on the shoulders of its keeper. These may be the hounuman,† a monkey regarded with some degree of religious veneration by the Indians, and frequently domesticated by them. They appear to be of the same species as those represented in the large bas-relief from the northwest palace of Nimroud,‡ which are covered with small spots, probably to denote long hair.

In a separate group are two monkeys or apes, whose strength and ferocity are indicated by thick chains passed round their bodies, and held by keepers. The first raises a fore-paw to its mouth; and wears a necklace of beads. It may be the bruh,§ the largest of the Indian monkey tribe; and it is not altogether unlike that animal in shape. In the bas-relief it is even larger than the man; but the sculptor probably exaggerated its size. The other monkey is distinguished from the rest by a hood or mane rising above the head and falling over the shoulders. This peculiarity may identify it with the wanderer, or maned ape of India.||

The only birds represented on the Assyrian monuments hitherto discovered, are the eagle or vulture, the ostrich and the partridge, and a few smaller birds at Khorsabad, whose forms are too conventional to permit of any conjecture as to their species.

The vulture or eagle—for the bird is rarely delineated with sufficient accuracy to enable us to decide which—is continually seen over the heads of the conquerors in battle, and in triumphal processions, and was probably typical of victory. It

* The only other monkey without a tail, is, I believe, the chimpanzee of Africa.

† *Simia Entellus*.

‡ Vol. I. p. 119. An engraving of this is included in my "Monuments of Nineveh."

§ *Simia Nemestrinus*.

|| *Simia Silenus*.

is also represented feeding on the bodies of the slain, and flying away with the entrails.

The ostrich was only found as an ornament on the robes of figures in the most ancient edifice at Nimroud. As it is accompanied by the emblematical flower, and is frequently introduced on Babylonian and Assyrian cylinders, we may infer that it was a sacred bird.

In sea and river scenes fish and shells are introduced, but the forms appear to be conventional; there are no distinctions to mark any particular species.* In the rivers are seen crabs, eels or water-snakes, and small turtles. When the sculptor wished to indicate the sea, he made these fish larger, and added others, which are only inhabitants of salt water, such as the star-fish. A kind of crocodile is also represented in the sea-pieces.†

With the exception of the vine, palm, and fir, the trees of the Assyrian bas-reliefs are conventional in their forms. The sculptor introduced them merely to show the nature of the country in which the events recorded took place. In general, the Assyrian artist appears to have been far less minute and exact in delineating secondary objects than the Egyptian, who as carefully preserved the character of the details, as he did that of the principal figures in his subject.

* See woodcut, p. 216.

† In the hieratic papyri certain fish are mentioned as brought from the Puharuta, or Euphrates, to Egypt (Select Papyri, pl. lxxv. l. 7), and another fish or fishy substance, called "Rura," as coming from the land of the great waters, Mesopotamia. (Ibid. xcvi. l. 7.) In the same papyrus (Ibid. xcvi. l. 8) are mentioned horses (*Atar*) and fine cattle from the Saenkar, or Sinjar.

CHAPTER VII.

A GENERAL inquiry into the nature of the worship of the Assyrians would be beyond the scope of these volumes. I will merely point out how far their religious system is illustrated by the newly discovered monuments, and what information, when better understood, they are likely to furnish on the subject. As I have more than once had occasion to observe, a marked distinction may be traced between the religion of the earliest and latest Assyrians. It is probable that corruptions gradually crept into their theology. Originally it was a pure Sabæanism, in which the heavenly bodies were worshipped as mere types of the power and attributes of the supreme deity. Of the great antiquity of this primitive worship, there is abundant evidence ; and that it originated amongst the inhabitants of the Assyrian plains, we have the united testimony of sacred and profane history. It obtained the epithet of perfect, and was believed to be the most ancient religious system, having preceded even that of the Egyptians.*

* "Ægyptiis vero antiquiores esse magos Aristoteles auctor est in primo de philosophiâ libro." (Theopomp. Frag.) Iamblichus de Myst. p. 3, ed. Gale, *ἡμῖς δὲν τὰ μὲν Ἀσσυρίων πάτρια (in some MSS. πρώτα) δόγματα παραδώσομεν σοι μετὰ ἀληθείας τὴν γνώμην.* The identity of many of the Assyrian doctrines with those of Egypt, is alluded to by Porphyry and Clemens. (See Gale, *ibid.* p. 185.) I am indebted to Mr. Birch for the following observations on this subject.

"There can be no doubt of the Sabæanism of the Chaldees, and apparently of the early Assyrians, whose pantheon, from its fusion of human and animal forms, resembles the Egyptian and Hindhu. The relation of religion with astronomy is, however, more striking in Assyria than in Egypt ; the system of the latter country

On the earliest monuments we have no traces of fire-worship, which was a corruption of the purer form of Sabæanism; but in the bas-reliefs of Khorsabad and Kouyunjik, as well as on a multitude of cylinders of the same age, we have abundant proofs of its subsequent prevalence in Assyria. Although we may not, at present, possess sufficient materials to illustrate the most ancient Sabæanism of the Assyrians, we may, I think, pretty confidently judge of the nature of the worship of a later period. The symbols and religious ceremonies represented at Khorsabad and Kouyunjik, and on the cylinders, are identical with those of the ancient monuments of Persia; at the same time, the sculptures of Persepolis, in their mythic character, resemble in every respect those of the Assyrians. We have the same types and groups to embody ideas of the divinity and to convey sacred subjects. When the close connection, in

being *solar*, while the Assyrian worship was rather *astral*. On the Babylonian cylinders and monuments, the sun and moon constantly occur, and often seven stars arranged more in the manner of the Pleiads than of the Great Bear, but probably the latter. Zodiacal signs are frequently placed in the area along with the sun, moon, and seven stars, and show unequivocally that the Greeks derived their notions and arrangements of the Zodiac from the Chaldees: thus, I. a fish (Cullimore, on Cyl. Nos. 19, 28, 88, 113) stands for *pisces*; II. the extraordinary combination, Capricorn (Ibid. 29, 30, 32), on cylinders bearing, in the lapidary Babylonian cuneiforms, the name of Nebuchadnezzar; III. a woman, Virgo (Ibid. 50, 94, 117, 91); IV. the two men, Gemini (Ibid. 65, 70, 94) with Capricorn (Ibid. 71); VI. the bull, Taurus (Ibid. 91, 92, 106, 156); VII. the archer, Sagittarius (Ibid. 107). Other signs appear to be, IX. a man, probably Aquarius (Ibid. 51, 95, 66, 112); X. an uncertain and ill-defined animal, perhaps a dog (Ibid. 51, 52, 53, 57); XI. a goat (Ibid. 107, 136, 95, 93, 112, 113); XII. a lion, Leo (Ibid. 91, 94). I do not pretend to explain every symbol on these cylinders, but all those which I have selected, are placed in the area, are not essential to the general subject, and are of smaller proportions than the principal figures, which may also have an astronomical import. The identity of Nimrod and the constellation Orion, is not to be rejected; and Nimrod may be one of the divinities standing on a dog with eight stars behind him (Ibid. 157). Another god with four wings, each terminating in a star (Ibid. 153), is apparently a constellation, as also the god seated on a throne with eight stars all round him (Ibid. 153).” The strange animal forms on the Babylonian relic called the “Caillou de Michaud,” have apparently some reference to the zodiacal signs: amongst them is the scorpion.

early ages, between religion and art is borne in mind, it will be at once conceded, that a nation like the Persian would not borrow mere forms without attaching to them their original signification.* If even this were not, as a general rule, the case, there is still at Persepolis sufficient to prove that the religious symbols of the Persians were adopted from the Assyrians. The form of supreme deity (the winged figure within the circle), and the types of wisdom and power, are precisely similar on the monuments of both people. Moreover, the testimony of Herodotus leads to the same conclusion: "The Persians adore," says he, "the sun, the moon, earth, fire, water, and the winds, which may be termed their original divinities. In after times, from the example of the Assyrians and Arabians, they added Urania (Venus) to the number." From this expression it may be inferred that the worship of Venus was added by both nations to a system identically the same.†

The identity of the Assyrian and Persian systems appears also to be pointed out by the uncertainty which exists as to the birthplace and epoch of Zoroaster. According to the best authorities, he was a Chaldæan, who introduced his doctrines into Persia and central Asia.‡ The Persians themselves may

* The connection, as exhibited by art, between Assyria and Persia, illustrated in a previous chapter, is sufficient, I think, to prove the origin of the symbols and myths of the Persians.

† These facts show that it is unnecessary, with Heeren and other German writers, to seek for the origin of the monsters of Persepolis in Bactria and central Asia. It has long been a favorite speculation in Germany to trace the source of all religious systems to the great table-land of the Asiatic continent, from whence, according to this theory, it spread into the lower country, to the Persians and their neighbors. But when Persia was a mere province, and long before her name is found amongst the civilized nations of antiquity, the religious system of the Assyrians was not only perfected, but was falling into decay. The Assyrian empire had ceased to exist before its myths and symbols were transferred, with its arts, to the walls of Persepolis.

‡ The country of Zoroaster, the time of his birth, the nature of his doctrines, and the authenticity of those attributed to him, are amongst the many disputed questions of ancient history. We must presume that there were two persons, if not more, of the same name, if we wish to reconcile the conflicting accounts. According to some, Zoroaster was a king of Bactria in the time of Niuis and Semiramis. Cephalaion and Moses of Chorene assert that he was born on the same day as Semi-

have recognized the Assyrian source of their religion when they declared Perseus, the founder of their race, to have been an Assyrian.*

The origin of the Chaldæan theology has ever been a favorite theme of the poet and philosopher. The Assyrian plains, uninterrupted by a single eminence, and rarely shadowed by a passing cloud, were looked upon as a fit place for the birth of a system which recognized the heavenly bodies as types of the supreme power, and invested them with supernatural influences. The wonderful regularity of their periodical movements, their splendor, and even their effects upon the physical world, must have been apparent to the Chaldæan shepherd long before they became the study of the philosopher and the priest. Whilst he watched his sheep by night, he marked the stars as they rose above the horizon, and learned to distinguish one from another, and to invest the most remarkable groups with distinct forms. If the attributes of the Deity were to be typified—if the limited intellect of man required palpable symbols to convey ideas which he could not understand in the abstract, more appropriate objects could not have been chosen than those bright luminaries whose motions and influences were enveloped in mystery, although they themselves were constantly present. The transition from this adoration to a national system of astronomy is natural; and it is not surprising that the Chaldæans, being the first to invest the heavenly bodies with sacred properties, should have been also the first to cultivate the

ramis. Pliny places his birth many thousand years before that of Moses; whilst others would fain bring the time of his ministry down to the reign of Darius Hystaspes. According to Suidas he was a Chaldæan. That the fire-worship did not originate with any Zoroaster may perhaps be inferred from the concurrent testimony of ancient authors. According to a fragment of Apollonius (69 ed. Muller), Ninus taught the Assyrians to worship fire: and so Marcellinus (l. 23), "Cujus scientiis seculis prisicis multa ex Chaldæorum arcanis Bactrianus addidit Zoroastria."

* Herodotus, l. vi. c. 54. Some traditions made this Perseus a great astronomer, who instructed men in the knowledge of the stars. Περσεύς ὁ Ἥλιος, Perseus is the sun, says the scholiast in Lycophr. v. 18. According to some, he married Astarte, the daughter of Belus. All these traditions point to his Assyrian origin.

sublimest sciences.* The periodical movements of the heavenly bodies were ascertained by constant observations, originating probably in religious duties; their causes were investigated, and in process of time their motions were calculated and predicted. At a very early period the Assyrian priests were able to fix the date of events by celestial phenomena, and to

* "Principio Assyrii, propter planitiem magnitudinemque regionum quos incolebant, cum cœlum ex omni parte patens et apertum intuerentur, trajectiones motusque stellarum observaverunt." (Cicero de Divin. l. i.) The greatest of our modern poets has thus beautifully conveyed the sentiment and philosophy of this Chaldæan star-worship:—

"Chaldæan shepherds, ranging trackless fields,
Beneath the concave of unclouded skies
Spread like a sea, in boundless solitude,
Looked on the polar star, as on a guide
And guardian of their course, that never closed
His steadfast eye. The planetary Five
With a submissive reverence they beheld;
Watched, from the centre of their sleeping flocks,
Those radiant Mercuries, that seemed to move,
Carrying through ether, in perpetual round,
Decrees and resolutions of the Gods;
And, by their aspects, signifying works
Of dim futurity, to Man revealed.

The imaginative faculty was lord
Of observations natural: and, thus
Led on, those shepherds made report of stars
In set rotation passing to and fro,
Between the orbs of our apparent sphere
And its invisible counterpart, adorned
With answering constellations, under earth,
Removed from all approach of living sight
But present to the dead; who, so they deemed,
Like those celestial messengers, beheld
All accidents, and judges were of all."

The Chaldæans maintained their pre-eminence as astronomers until the complete extinction of the Perso-Babylonian empire. They instructed Thales and Pythagoras in the most flourishing period of Greece, and Eudoxus and Aristotle as Babylon fell; Ptolemy, in the second century of the Christian era, still had recourse to their calculations. (See some valuable observations in Grote's History of Greece, vol. iii. c. 19.)

connect the public records with them. When Alexander entered Babylon, he is said to have been presented with the archives of the empire, verified by astronomical calculations, which extended over a period of many centuries;* and Callisthenes was able to send to his relation and friend, Aristotle, the celestial observations of 1900 years.† We may reasonably suspect that many accounts of the astronomical skill of the Chaldæans are greatly exaggerated; but as Nabonassar did fix a period, by a well-authenticated astronomical observation, 745 B. C., it may be inferred that long before his time the priests had acquired sufficient knowledge of the science to predict and determine celestial phenomena.

I will now proceed to point out the religious types and emblems which are found on all Assyrian monuments. Representations of the heavenly bodies, as sacred symbols, are of constant occurrence in the most ancient sculptures. In the bas-reliefs we find figures of the sun, moon, and stars, suspended round the neck of the king when engaged in the performance of religious ceremonies. These emblems are accompanied by a small model of the *hornea* cap worn by winged figures, and by a trident or bident.‡

I have not found these symbols on the monuments of Kouyunjik and Khorsabad, but they occur on a bas-relief of a doubtful period, built into the walls of the southwest palace of Nimroud.† In the oldest edifice they are constantly intro-

* According to a foolish tradition 470,000 years. (Diod. Sic. l. ii. and Cicero de Divin. l. ii.) It is scarcely necessary to allude to the exaggerated statements of various ancient authors as to the period comprised in the celestial observations of the Chaldæans.

† Simplicius, Aristot. de Cœlo, p. 123.

‡ It is very remarkable that, with the exception of the horned cap, these are precisely the symbols found on the sacred monuments of India; which, accompanied as they are by the sacred bull, might be mistaken for Assyrian. The sun, moon, and trident of Siva raised on columns adorn the entrances to temples (such as that of Bangalore, of which an engraving is given in Daniel's India). This identity might easily lead to a digression, which would scarcely suit the limits of this work.

§ According to Mr. Ross's account of the rock-tablets of Bavaria (note, p. 143),

duced as ornaments, particularly on the chariots. They are frequently accompanied by seven disks, which probably represent the seven great heavenly bodies, that mysterious number so prevalent in the Sabæan system, or perhaps the Pleiads, like which they are grouped.*

It will be observed that in the earliest sculptures of Nimroud, the king is only seen in adoration before one symbol of the deity—the figure with the wings and tail of a bird inclosed in a circle, resembling the Ormuzd of the Persian monuments. Although there are eagle-headed figures, and other mythic forms, yet in no case do they appear to be objects of worship. The king is generally standing or kneeling beneath this figure in the circle, his hand raised in sign of prayer or adoration.† The sacred tree is before him, but only, it may be presumed, as a type. The same symbol is also seen above him when in battle, and during his triumphal return. It is never represented above any person of inferior rank, but appears to watch especially over the monarch, who was probably typical of the nation. When over the king in battle, it shoots, against the enemies of the Assyrians, an arrow, which has a head in the shape of a trident. If it presides over a triumph, its action resembles that of the king, the right hand being ele-

they appear to be represented in those bas-reliefs. The sun, moon, and stars are common emblems on cylinders of all epochs. They were adopted by the Persians, are found on coins and gems of the Sassanian period, passed from the Persians to the Arabs, and are still preserved in the insignia of the Turks. The numerous symbols and figures which occur on Assyrian and Babylonian cylinders, evidently refer to a mythological system; but a particular notice of them would lead me into a dissertation unsuited to the limits of these volumes.

* See note, p. 247, Vol. I. The seven stars are mentioned in Amos, v. 8, and in Job, ix. 9, xxxviii. 31, where they are translated in our version the Pleiads. The Pleiads are, however, only six in number; the seven stars are more probably Arcturus.

† Two kings are frequently represented kneeling or standing beneath the winged figure; but whether the two are representations of the same monarch, or whether they show the father and son associated in the government, or two friendly monarchs concluding a treaty, I cannot determine. The two figures are identical in every respect, and I am inclined to think that but one monarch is intended.

vated, and the left holding the unbent bow; if over a religious ceremony, it carries a ring, or raises the extended right hand. This emblem does not always preserve the form of the winged figure in the circle, but sometimes assumes that of a winged globe, wheel or disk, either plain, or ornamented with leaves like a flower. In this shape, its resemblance to the winged globe of Egypt cannot be overlooked.*

This well-known symbol constantly occurs on the walls of Persepolis, and on Persian monuments



Emblems of the Deity. (N. W. Palsoe, Nimroud.)

* This is one of the representations most intimately connected with Egypt resembling the symbol found on the cornices of tablets as early as the twelfth dynasty. In Egypt it was the sun, with the wings of a scarab; a red solar disk, and two pendent uræi. It is called the "Hut" (the name of the Coptic Atfoo, or Edfoo, Apollinopolis magna). M. Lajard, as I have already observed, endeavors to derive the Egyptian from the Assyrian emblem. (*Observations sur la Croix Ansée*, Mem. de l'Acad. vol. xvii.) Whether the winged figure in the circle, or the winged globe, or simply the sun, was the original form, I will not attempt to conjecture. According to M. Lajard, this symbol is formed by a circle or crown, to denote time without bounds, or eternity; encircling the image of Baul, with the wings and tail of a dove, to show the association of Mylitta, the Assyrian Venus—thus presenting a complete triad.

of the Achæmenian dynasty, as that of the supreme divinity. It is also seen in the bas-reliefs of Pterium, and furnishes additional evidence in support of the Assyrian or Persian origin of those rock-sculptures, and of the Assyrian influence on Asia Minor.*

We may conclude from the prominent position always given to this figure in Nimroud sculptures, and from its occurrence on Persian monuments as the representation of Ormuzd, that it was also the type of the supreme deity amongst the Assyrians. It will require a more thorough knowledge of the contents of the inscriptions than we at present possess, to determine the name by which the divinity was known. It may be conjectured, however, that it was Baal, or some modification of a name which was that of the great god amongst nearly all nations speaking cognate dialects of the Semitic or Syro-Arabian language.† According to a custom existing from time immemorial in the East, the name of the supreme deity was introduced into the names of men. This custom prevailed from the banks of the Tigris to the Phœnician colonies beyond the pillars of Hercules; and we recognize in the Sardanapalus of the Assyrians, and the Hannibal of the Carthaginians, the identity of the origin of the religious system of two nations, as widely distinct in the time of their existence, as in their geographical position. To the Jews the same name

* See page 225. Mr. Scharf is also inclined to trace in the oval form of the harpies of the Xanthian monument some connection with the winged globe, which, from the Persian origin of those figures, is not unlikely. (Observations on the Peculiarities of the Sculptures seen on the Monuments of ancient Lycia, by G. Scharf, Junior, p. 12.)

† As the supreme deity he came to be identified with the sun, the greatest divine manifestation in the Sabæan system. Hence much mythological confusion between Belus and Apollo, and the representation of the two with the same attributes. Thus the Phœnicians, according to Sanchoniathon, "stretched their hands towards the sun; for him they thought the only Lord of Heaven; calling him Beelsamin, which in Phœnician is Lord of Heaven, but in the Greek, Zeus." (Cory's Fragments.) "Lingua punicâ Bal Deus dicitur, apud Assyrios autem Bel dicitur quadam sacrorum ratione Saturnus et Sol." (Servius on Æneid, i. 733.)

was familiar, and was applied very generally to the gods of the surrounding nations. Even under its various orthographical modifications, there can be no difficulty in detecting it.

From this Baal came the Belus of the Greeks, who was confounded with their own Zeus, or Jupiter. But whether he was really the father of the founder of the empire, or was himself its founder, as some have asserted, and then came to be considered, after the fashion of the Greek theology, its principal deity, there may be good reason to doubt.*

The descriptions handed down to us of the contents of the Babylonian temples are highly interesting, as illustrative of the monuments recently discovered. According to Diodorus Siculus, the three deities worshipped in the great temple at Babylon, were Belus (or Jupiter), Hera, and Rhea, whose statues were of beaten gold. Belus was represented upright, *in the act of walking*. His statue, weighing 1000 Babylonian talents, was forty feet in height. Rhea, seated on a chair of gold, had two lions at the sides of her knees, and near her were large silver serpents. Hera stood erect, holding in her right hand a serpent by the head, and in her left a sceptre ornamented with precious stones. Before these deities was a table of silver, and on it were placed three golden cups, one for each deity.

In a bas-relief, probably of the later Assyrian period, and discovered in the ruins of the southwest palace at Nimroud, we have a procession of warriors carrying on their shoulders

* According to Castor, Belus was king of the Assyrians, and, after his death, was esteemed a god. (Cory's Fragments, p. 65.) It is singular to find the Persians subsequently carrying as their principal religious emblems the figures of Belus and Ninus. (See p. 260.) They were either looked upon as divinities, or, as some have conjectured, represent the dominion of the Persian king over the Assyrian and Babylonian empires. The Roman author may have substituted these names for others. It has been mentioned that "Nini" is an emendation by Scaliger, the MSS. having "Pacis." Belus was confounded with Mars "After Ninus reigned Thyrras, whom they named Mars. He was very mighty and warlike, and the Assyrians placed him amongst the gods, naming him Belus, or Mars, the god of battles." (Arch. of John of Antioch, in Cramer, *Anecdota Græca*, vol. ii. p. 386.)

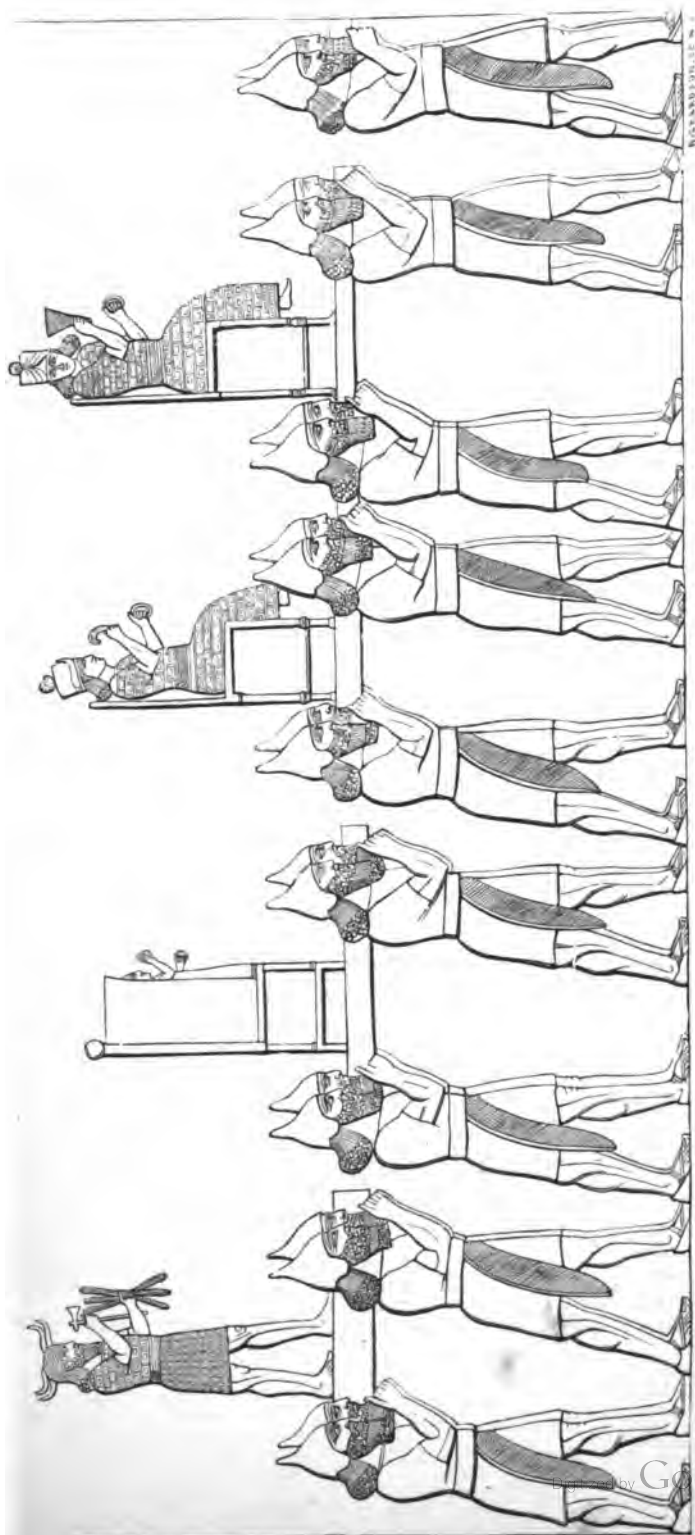

BRITISH MUSEUM

IDOLS CARRIED IN PROCESSION BY ASSYRIAN WARRIORS.

(S. W. Ruins Nimrud)

THE NEW YORK
PUBLIC LIBRARY.
ASTOR LENOX AND
TILDEN FOUNDATIONS

four images. It is doubtful whether they are the idols of a conquered people borne in triumph by the conquerors, or whether the sculpture commemorates the celebration of some religious ceremony, during which the statues of the gods were carried in procession by the people, like those of the Virgin and saints in Roman Catholic countries. It may record an expedition against the revolted Babylonians, whose divinities, as described by Diodorus, can, perhaps, be identified with the figures in the bas-relief; but, as nearly the same forms are found on the rock-tablets of Malthaiyah—pure Assyrian monuments—it is more probable that they are Assyrian. The gods of the two cities, Nineveh and Babylon, were, there can be little doubt, nearly the same.

The first deity mentioned by Diodorus is Jupiter, the Belus, or Baal, of the Babylonians.* He is seen, he says, in the act of walking. The commentators have objected to this description, that the chief of the gods would scarcely have been represented otherwise than seated on his throne. The bas-relief, however, confirms the statement of the geographer; for the god is represented with one leg in advance, as if in the act of walking. That it is the figure of Baal, or the great divinity of the Babylonians, may be inferred from the passage in the Epistle of Jeremy.† “Now shall ye see in Babylon,” says the prophet, “gods of silver, and of gold, and of wood, borne upon shoulders.‡ And he that cannot put to death one that offendeth him holdeth a sceptre, as though he were a judge of

* Berossus in Alex. Polyhistor, apud Euseb. Chron. lib. i. c. 2.

† This epistle is supposed to have been written by the Prophet Jeremiah to the Jews when they were carried captive to Babylon. He intended it as a warning against the idolatry of the Babylonians, whose gods he describes, that his countrymen might be aware of the impositions practised upon the worshippers of those idols, and might avoid falling into similar errors. That the Jews looked upon the letter as genuine, is shown by the reference to it in 2 Macc. xi. 2, 3.

‡ Compare Isaiah, xlvi. 6, 7. “They lavish gold out of the bag, and weigh silver in the balance, and hire a goldsmith: and he maketh it a god: they fall down, yea, they worship. *They bear him upon the shoulder, they carry him, and set him in his place.*”

the country. He hath also in his *right hand a dagger and an axe.*" He is thus seen in the bas-relief; and the introduction of the axe could scarcely have been accidental. The sculpture; therefore, appears to corroborate the authenticity of, and to illustrate the epistle.

The same document furnishes us with several interesting details as to the nature of the Babylonian idols. We learn that they were frequently made of wood and laid over with gold, and that parts of them were polished by the workmen. Crowns were made for their heads; they were decked in garments, and covered with purple raiment;* and fires or lamps were kept burning before them.

This account appears to confirm the assertion of Diodorus, that the statues in the Babylonian temples were made of beaten gold, or that they were gilded so as to have that appearance. Nor must the proportions assigned to them by the geographer be deemed exaggerated, if we remember that the image of gold set up by Nebuchadnezzar in the plain of Dura, was three-score cubits in height, and six cubits in breadth!†

The figure in the bas-relief has horns on its head; and would consequently appear to be connected with the divinity wearing the horned cap, so frequently represented in the Assyrian sculptures: but they have nothing else in common. On the older monuments, indeed, we have no figure which corresponds with any description of Belus furnished by the Greeks. The bas-relief just described may belong to the period when the older forms were corrupted, and when a more gross idolatry had succeeded to purer Sabæanism.‡

* Compare Jeremiah, x. 9. "Silver spread into plates is brought from Tarshish, and gold from Uphaz, the work of the workman, and of the hands of the founder: blue and purple is their clothing: they are all the work of cunning men." These idols at Babylon were of gold, silver, brass, iron, wood and stone. (Daniel, v. 4.)

† Daniel, iii. 1.

‡ Selden (*de Diis Syriis*, cap. i. p. 123) has collected the authorities on the Semitic Baal or Bel, connecting him with the Zeus of the Greeks, the Jupiter of the Romans, and Apollo and the Sun.

We have little difficulty in identifying Hera, the second deity mentioned by Diodorus, with Astarta, Mylitta, or Venus; whose worship, according to the united testimony of scripture and the ancient authors, formed so prominent a part of the religious system of all the Semitic nations, and particularly the Assyrians.* She held a serpent in one hand; and so she is represented in the Egyptian tablet.† In the bas-relief of the procession of the gods, it is not impossible that the object in the hand of the sitting figure, which has been defaced, may also have been a serpent. An inquiry into the origin and nature of this divinity, and of the emblems under which she was represented, would lead to a digression unsuited to the object and limits of these volumes. We have proofs of the prevalence of her far-extending worship on the earliest monuments with which we are acquainted; a female winged figure, partly naked, and undoubtedly representing the divinity presiding over generation, being, as I have already mentioned,‡ introduced into the embroideries of robes in the most ancient palace at Nimroud. But, whilst there can be no question as to the object of this figure, it is remarkable that in no part of the ruins have any traces been discovered of that peculiar emblem which frequently occurs on the cylinders of Assyria, and which was typical of the worship of Venus amongst most Asiatic nations. Indeed, the absence of unseemly symbols on the Assyrian monuments is worthy of remark, and shows a considerable purity of taste and feeling: even the two figures to which I have alluded would escape notice except on a minute examination. That this worship, even under its most degrading forms, did exist, can scarcely be doubted. Tradition has traced its introduction to Semiramis—that is, to the very earliest period. We have no evidence, however, of the corruption of morals, which might naturally be expected to

* Plutarch (in *Vit. Crass.*) and Julius Firmicus Maternus (*de Errore Prof. Relig.* w. p. 12, ed. Münter) identify Hera with the Assyrian Venus.

† See p. 169.

‡ See p. 171.

accompany it; nor do the monuments hitherto discovered present any proof of the existence in Assyria, of that infamous law which, according to Herodotus, marked the rites of the goddess at Babylon.*

She was "the Queen of Heaven," frequently alluded to in the sacred volumes.† Diodorus mentions the vases which were placed on tables before the divinities in the Babylonian temple; the prophet describes the drink offerings to her; and in the sculptures, the king is constantly represented with a cup in one hand, in the act of performing some religious ceremony. The planet, which bore her name, was sacred to her; and in the Assyrian sculptures, a star is placed upon her head. She was called Beltis, because she was the female form of the great divinity, or Baal; the two, there is reason to conjecture, having been originally but one, and androgyne.‡ Her worship penetrated from Assyria into Asia Minor, where its Assyrian origin was recognized.§ In the rock-tablets of Pterium she is represented, as in those of Assyria, standing erect on a lion,|| and crowned with a tower, or mural coronet; which, we learn from Lucian, was peculiar to the Semitic figure of the goddess.¶

* The 43rd verse of the Epistle of Jeremy is a singular Confirmation of the existence of a practice which, notwithstanding the charges of credulity frequently brought against Herodotus for relating it, appears undoubtedly to have prevailed at Babylon. Similar practices amongst certain tribes still inhabiting the East is a further corroboration. We find that it also prevailed among several nations of Asia Minor of Semitic descent; for instance, the Lydians and Cappadocians, and the Armenians, who evidently owed its introduction to the Assyrians. (Herod. l. 93; Strabo, xi. 16, and xii. 36.)

† Jeremiah, vii. 18, xlv. 17, &c.

‡ Hesychius, voce Βελις; Megasthenes, apud Abydenum; Euseb. Præpar. Evang. ix. 41; Plut. in Vita Crassi. The Persian Mithra was also originally androgyne.

§ For the worship of Anaitis, or the Assyrian Venus, in Armenia, we have the authority of Strabo, Geog. l. xi.; Pliny, Hist. Nat. l. iv. c. 90; Dion Cassius, l. xxxvi. c. 32—36. A district of that country was called the Anaitic region.

|| Texier, Description de l'Asie Mineure, vol. i. part i. plate 78.

¶ In the Syrian temple of Hierapolis she was represented standing on a lion, crowned with a tower, and having a cestus or zone round her waist. (De Dea Syria, 31, 32.) Mylitta (Astarta), with her feet on the lion, is also mentioned,



**HERA, OR THE ASSYRIAN VENUS (From a Rock Tablet
near the ancient Pterium,)**

THE NEW YORK
PUBLIC LIBRARY.
ASTOR, LENOX AND
TILDEN FOUNDATIONS.

This may have been a modification of the high cap of the Assyrian bas-reliefs. To the Shemites she was known under the names of Astarte,* Ashtaroth, Mylitta, and Alitta, according to the various dialects of the nations amongst which her worship prevailed.

The goddess Rhea with her lions and serpents, as described by Diodorus, may perhaps be recognized both in the rock-sculptures of Malthaiyah, and in the bas-reliefs from Nimroud.† In these sculptures she is seen, like Astarte and other divinities, with a star upon her head.‡ This shows a connection with some system in which the heavenly bodies formed a principal feature; but the representation in a human form of the celestial bodies, themselves originally but a type, was a corruption which appears to have crept at a later period into the mythology of Assyria; for in the more ancient bas-reliefs, figures with

Macrob. Saturn. i. 23. May she be connected with the "El Maozem," the deity presiding over bulwarks and fortresses, the "god of forces," of Daniel, xi. 38.?

* It has been conjectured that this name was derived from the word "star" in the primitive Indo-European languages, from whence, it is well known, came the Persian female name Satara, the daughter of Darius, and that of the biblical Esther. David Kimchi, a Hebrew commentator, derives the name of Ashtaroth from a word signifying an egg, a curious coincidence with the tradition of Aphrodite and Semiramis. (Selden, De Diis Syriis, c. 2.) In a fragment of Sanchoniathon, Astarte, travelling about the habitable world, is said to have found a star falling through the air, which she took up, and consecrated in the holy island Tyre; hence the Phœnicians said that Astarte was Aphrodite. (Cory's Fragments.) According to a tradition resembling the Orphic legends, Aphrodite was born of an egg, which fell out of heaven into the Euphrates, and was incubated by two pigeons. (Hygin. fab. 197, Schol. ad Geron. 233.) Also Ampelius (l. 2) says,—"*Dicitur et in Euphrate fluvio ovum picis in ora fluminis columbas assediisse dies plurimos, et exclusisse deam benignam et misericordiam hominibus ad bonam vitam.*"—connecting the fables of Semiramis and Derecto.

† This divinity was probably the *Ομορωκα* or *Ομορκα* of Berosus (apud Alex. Polyhistor; Euseb. Chron. l. i. c. 11), the Thalath (*Θάλατθ*) of the Chaldees. She was particularly honored by the Trojans and Phrygians, who may have received her worship from the Assyrians. (Strabo, l. x.)

‡ This custom of placing the figure of a star upon the heads of idols is probably alluded to by the prophet. "The star of your god, which ye made to yourselves." (Amos, v. 26.)

caps surmounted by stars do not occur, and the sun, moon, and planets stand alone.

On the earliest Assyrian monuments, one of the most prominent sacred types is the eagle-headed, or vulture-headed, human figure.* Not only is it found in colossal proportions on the walls, or guarding the portals of the chambers, but it is also constantly represented amongst the groups on the embroidered robes. When thus introduced, it is generally seen contending with other mythic animals, such as the human-headed lion or bull; and in these contests it appears to be always the conqueror. It may, hence, be inferred that it was a type of the supreme deity, or of one of his principal attributes.† A fragment of the Zoroastrian oracles preserved by Eusebius, declares that "God is he that has the *head of a hawk*. He is the first, indestructible, eternal, unbegotten, indivisible, dissimilar; the dispenser of all good; incorruptible; the best of the good, the wisest of the wise: he is the father of equity and justice, self-taught, physical and perfect, and wise, and the only inventor of the sacred philosophy."‡ This figure may also be identified with the god Nisroch,§ in whose temple Sennacherib was slain by his sons; for the word Nisr signifies, in all the Semitic languages, an eagle.¶ Sometimes the head of this bird is added to the body of a lion. Under this form of the Egyptian hieraco-sphinx it is the conqueror in combats with other symbolical figures, and is frequently represented as striking down a gazelle or wild goat. It also closely

* See woodcut facing page 71, Vol. I.

† Numerous instances will be found in my "Monuments of Nineveh." It is possible that these various forms represent different attributes of one and the same deity, and that the victory of the eagle-headed figure over the lion, or bull, may denote the superiority of intellect over mere physical strength.

‡ Eusebius, Præp. Evang. lib. i. c. 10; Cory's Fragments, page 239.

§ 2 Kings, xix. 37. Josephus (Antiq. Jud. l. x. c. 1) calls this image *Arascus*; *Iaiah*, *Asarak*; the Septuagint, *Μεσροπέχ*.

¶ The form of this deity was conjectured to be that of an eagle, long before the discovery of the Assyrian sculpture. (And. Beyer's and Joh. Seldeni de Dis Syria Syntag. addit. page 325.)

resembles the gryphon of the Greek mythology, avowedly an eastern symbol, and connected with Apollo, or with the sun, of which the Assyrian form was probably an emblem. It may now be inferred, that the Greeks derived their mythical figure from the Assyrians.*

The winged human-headed lions and bulls, those magnificent forms which guarded the portals of the Assyrian temples, next deserve notice. Not only are they found as separate sculptures, but, like the eagle-headed figures, are constantly introduced into the groups embroidered on the robes. It is worthy of observation, that, whenever they are represented, either in contest with the man, or with the eagle-headed figure, they appear to be vanquished. Such is also the case on cylinders. Frequently a human figure is seen suspending them in the air by the hind legs, or striking them with a mace. I have already ventured to suggest the idea which these singular forms were intended to convey—the union of the greatest intellectual and physical powers; but certainly their position with reference to other symbolical figures, would point to an inferiority in the celestial hierarchy. Although the andro-sphinx of the Egyptians was the type of the monarch, we can scarcely believe it to have been so amongst the Assyrians; for in the sculptures we find even the eagle-headed figure, the vanquisher of the

* Apollo himself was called Gryphenias. I hesitate to attempt, at present, the identification, with the images of the Assyrian sculptures, of any other of the Assyrian deities mentioned in the Bible—such as Nebo and Merodach, who, from their frequent introduction into the names of monarchs, appear to hold a high rank in the Assyrian Pantheon, or to be different appellations of the supreme deity; Sessach or Saah, whose festival was celebrated at Babylon by a kind of Saturnalia, in which the order of society, as at Rome, was for a period reversed; Succoth Benoth, sometimes identified with Astarte or Mylitta; Nergal, conjectured, according to the presumed Semitic or Indo-European origin of the name, to have reference to a fire worship, or to that of the sun under the form of a cock; and Adramelech and Anamalech, gods apparently of Assyrian origin. Of Khun, I have already spoken. Remphan does not occur in the Assyrian sculptures in his Egyptian form, unless the Priapean figure on the vase discovered at Nimroud (Vol. I. p. 119) has reference to his worship. As to all the Assyrian and Syrian deities, see Selden, *de Diis Syriis*.

human-headed lion and bull, ministering to the king. Whether the sphinx originated with the Assyrians, or the Egyptians, may now become a question of some interest. It may not, perhaps, be out of place to remark that it was first introduced into Egypt in the time of the eighteenth dynasty; when so many Assyrian peculiarities suddenly appear on Egyptian monuments, that we are involuntarily led to infer some close and intimate connection between the two countries.* The sphinx, as an architectural ornament, occupies nearly the same position in the edifices of Assyria and Egypt, being placed at the entrances to temples and palaces.

The winged bull with the human head is evidently a pure Assyrian type. Its position in the religious system seems to be identical with that of the andro-sphinx; and in the mythic groups, as well as in architecture, they both occupy the same place. Power was probably typified indiscriminately by the body of the lion and the bull.

Various other emblematical forms and types are found in the Assyrian sculptures—such as the winged horse, so closely resembling the Pegasus of the Greeks, that we can scarcely doubt the identity†—the wild goat, the ostrich, the dragon with the eagle's head, and the human figure with the head of a lion.

To all these images some mythic meaning was undoubtedly attached.‡. They were emblematical, representing either the

* Mr. Birch (on the Nimroud Ivories) mentions that Thothmes III. is represented as a winged sphinx on a scarabæus in the British Museum; and it would appear that this is the first appearance of the sphinx as an Egyptian type. He also alludes to a painting of the Queen Mu-t-shem-t of the twentieth dynasty as a winged sphinx.

† Note, in connection with this winged horse, the Assyrian origin of Perseus, see p. 336.

‡ The *Iynges*, or sacred birds, belonged to the Babylonian, and probably to the Assyrian religion. They were a kind of demons, who exercised a peculiar influence over mankind, resembling the ferouher of the Zoroastrian system. (Ignasius, de *Insomn.* p. 134. ed. Patav. Schol. Niceph.) The oracles attributed to Zoroaster describe them as powers animated by God.

*Νοούμεναι ἰύγγες παρῶθεν νοίονσι καὶ αἰράι
Βουλαῖς ἀρβίγκτοιαι κινούμεναι ὡστε νοῆσαι.*

THE
TILESON FOUNDATION
ADMISSIONS AND
TILESON FOUNDATIONS.

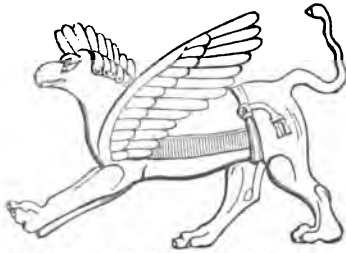

GRIFIN. (N. W. Palace, Nimroud.)
Page 349.



WINGED HORSE. (N. W. Palace
Nimroud.) Page 350.

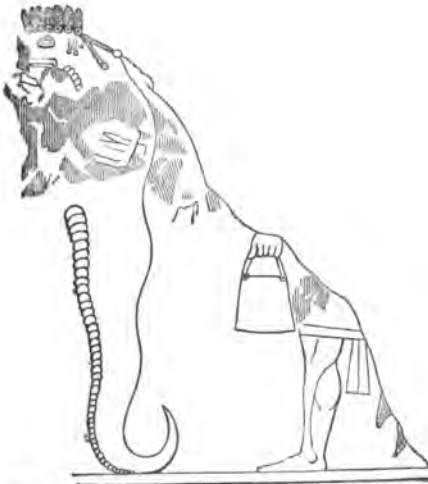

EAGLE-HEADED FIGURE. (s. w. Palace, Nimroud.)
Page 351.



WARRIORS CARRYING A BIRD. (Centre Palace
Nimroud.) Page 351.



THE FISH-GOD. (Khorsabad.)
Page 353.

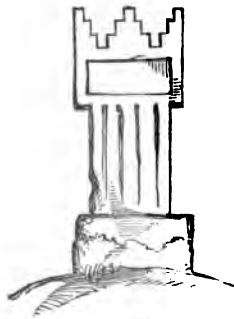

AN ALTAR, resembling that
on the Sassanian Coins,
(Khorsabad.) Page 354.
351. VOL. II.



FIRE-ALTAR. (Khorsabad.)
Page 354.

attributes of the Deity, or certain physical phenomena in nature. But I cannot venture, at present, to conjecture the signification of any of them; nor am I able to determine the character of the winged human figures which so frequently occur on the walls of Assyrian buildings. They may be the representations of presiding deities, or genii; or of priests who, during the celebration of sacred ceremonies, assumed that which was believed to be the outward form of the divinities. In two instances they were portrayed as females. Sometimes they bear animals or plants, either for sacrifice or as types. As they are frequently seen in an act of adoration before the king (whom they generally accompany), or before the mystic tree, their divine character may be questioned. They may perhaps be identified with the good spirits, or Amshaspands, of the later Persian theology.

The resemblance between the symbolical figures I have described, and those seen by Ezekiel in his vision, can scarcely fail to strike the reader. As the prophet had beheld the Assyrian palaces, with their mysterious images and gorgeous decorations, it is highly probable that, when seeking to typify certain divine attributes, and to describe the divine glory, he chose forms that were not only familiar to him, but to the people whom he addressed—captives like himself in the land of Assyria. Those who were uncorrupted by even the outward forms of idolatry, sought for images to convey the idea of the Supreme God. Ezekiel saw in his vision the likeness of four

(The intelligible Iynges themselves understand from the Father;
By ineffable counsels being moved so as to understand.)

(Zoroaster, *Oracul. Magn. ad Calcem Oracul. Sybill.* Ed. Gall. p. 80, and *Cory's Fragments*, p. 250.) Their images made of gold were in the palace of the king of Babylon, according to Philostratus. (Lib. i. c. 25, and lib. vi. c. 2.) They were connected with magic. (Selden, *de Dis Syriis*, p. 39.) It is possible that the bird borne by warriors in a bas-relief from the ruins of the centre palace, may represent the Iynges. This figure may, however, resemble the golden eagle carried before the Persian monarchs. (Xenophon, *Cyrop.* l. vii., *Anab.* l. ix.; Quintus Curtius, l. iii. c. 3.)

living creatures, which had four faces, four wings, and the hands of a man under their wings on their four sides. Their faces were those of a man, a lion, an ox, and an eagle. By them was a wheel, the appearance of which "was as it were a wheel in the middle of a wheel."* It will be observed that the four forms chosen by Ezekiel to illustrate his description—the man, the lion, the bull, and the eagle,—are precisely those which are constantly found on Assyrian monuments as religious types. The "wheel within wheel," mentioned in connection with the emblematical figures, may refer to the winged circle, or wheel, representing at Nimroud the supreme deity.† These coincidences are too marked not to deserve notice; and do certainly lead to the inference, that the symbols chosen by the prophet were derived from the Assyrian sculptures.‡

The symbolical figures of the Assyrians, as we might expect from the evident identity of the two nations, were placed, at a very early period, in the sacred edifices of the Babylonians. In the temple of Belus, according to Berossus,§ there were sculptured representations of men with two wings, and others with four, some having two faces, others the legs and horns of goats, or the hoofs of horses; there were bulls also with the heads of men, and horses with the heads of dogs.||

I must not omit to allude to the tradition preserved by Berossus, which appears to attribute to a foreign nation, arriving by sea, the introduction, at some remote period, of civilization and certain arts into Babylonia. According to the historian, there appeared out of the Erythrean, or Persian, Gulf, an animal endowed with reason, called Oannes. Its body was like

* Ezekiel, i. 16.

† See woodcuts, page 340.

‡ The lion with the wings of an eagle is also introduced as a type of strength and power by the prophets, who were intimate with the contents of the Assyrian and Babylonian temples. Compare Daniel, vii. 4.

§ Apud. Euseb. ed. Aucher, vol. i. p. 23.

|| "Behold every form of creeping things, and abominable beasts, and all the idols of the house of Israel, portrayed upon the walls round about." Ezekiel, viii. 10.)

that of a fish ; but under the head of the fish was that of a man, and added to its tail were women's feet. Its voice, too, was human, and it spoke an articulate language. During the day it instructed the Chaldæans in letters and in all arts and sciences, teaching them to build temples ; but at night it plunged again into the sea. Five such monsters appeared at different epochs in Babylonia, and were called "Annedoti."* The first was named the Musarus Oannes, and the last Odacon. Their images, he adds, were preserved in Chaldæa even to his day.†

In a bas-relief from Khorsabad representing a naval engagement, or the siege of a city on the sea-coast, we have the god nearly as described by Berosus. To the body of a man as far as the waist, is joined the tail of a fish. The three-horned cap, surmounted by the flower in the form of a fleur-de-lis, as worn by the winged figures of the bas-reliefs, marks the sacred character. The right hand is raised as in the representations of the winged deity in the circle. This figure is in the sea amongst fish and marine animals.‡

On Assyrian cylinders and gems, the same symbolical

* *i. e.* "coming out of," or "proceeding from."

† This fragment of Berosus is preserved by Apollodorus. (See Cory's Fragments, p. 30.) Such may have been the dragon of the Apocryphal book of Bel and the Dragon.

‡ This fish-worship extended to Syria, and appears to have been more prevalent in that country than in Assyria. The Dagon of the Philistines of Ashdod, evidently resembled the figure on the Assyrian sculptures and cylinders. When it fell before the ark, "the head and both the palms of his hands were cut off upon the threshold ; only the fish part of Dagon was left to him." (1 Samuel, v. 4. See the marginal reading, which is to be preferred to our version.) The same idol is mentioned in Judges, xvi. The meaning of the word in Hebrew is "a fish." Although this image, like that of the Assyrians, appears to have been originally male, at a later period, it became female in Syria, as we learn from Lucian (*de Dea Syria*), and Diodorus Siculus, who describes the idol at Ascalon with the face of a woman and body of a fish. (*Lib. ii.*) An ichthyolatry, connected with Dereto or Atergates, was perhaps confounded with the worship of Dagon. See the authorities on the subject collected in Selden, *de Dis Syriis*, c. 3, *de Dagon*.

figure is very frequently found, even more closely resembling in form the description of Berosus.*

It may be inferred that the worship of fire, a corruption of Sabæanism, originated, or generally prevailed in Assyria, about the time of the building of the Khorsabad and Kouyunjik edifices. There are no traces of it on earlier known monuments. From the forms of the altars in the sculptures, and from the symbols accompanying them, we may conjecture that the Persians adopted, not only their system, but their ceremonies, almost entirely from the Assyrians.† The fire-altar represented on Persian coins, even as late as the time of the Sassanian dynasty, was found in a bas-relief at Khorsabad.

In a sculpture from the same ruins two eunuchs are seen standing before an altar, performing some religious ceremony. They bear the square basket, or utensil, carried by the winged figures of the older bas-reliefs.

That the cone on the high stand, or altar, represents fire, appears to be shown by its having been painted red.

From the ruins of Kouyunjik we have a still more curious representation of similar ceremonies. Two eunuchs are standing before an altar upon which is the sacred fire. Two serpents appear to be attached to poles, and a bearded figure is leading a wild goat to the sacrifice.‡

On cylinders, evidently of the same period, the emblems and ceremonies of the Assyrian fire-worship so closely resemble those of the Persians, that, until the discovery of the Kouyunjik sculptures, I was inclined to attribute these relics to a time long posterior to the fall of the Assyrian empire.

Amongst the ruins of Khorsabad were discovered two cir-

* Numerous instances are given in Lajard's large work on the Worship of Venus.

† This identity between the religious systems of the Assyrians and Persians, affords as good an argument in favor of the Assyrian, as the Persian, origin of several of the nations of Asia Minor, the Cappadocians, for instance.

‡ On a very ancient bas-relief accompanied by a cuneiform inscription discovered by me in Susiana, a similar figure is seen leading a wild goat to an altar.

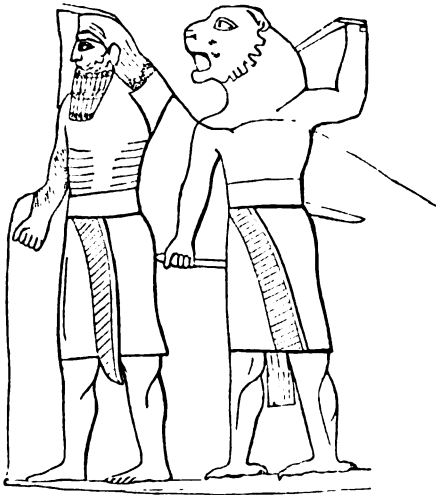

LION-HEADED FIGURE. (S. W. Palace, Nimroud.)
Page 350.



ALTAR, OR TRIPOD. (From Khorsabad.)
Page 354.



FIRE-ALTAR AND SACRIFICE. (Kouyunjik.) Page 354.

THE NEW YORK
PUBLIC LIBRARY.
ASTOR, LENOX AND
TILDEN FOUNDATIONS.

cular altars, which are so much like the Greek tripod, that they may be cited as an additional proof of the Assyrian origin of many forms and religious types, afterwards prevalent in Asia Minor and Greece. The altar is supported by three lion's paws. Round the upper part is an inscription, in cuneiform characters, containing the name of the Khorsabad king.*

The presence of eunuchs at religious ceremonies, not only as assistants, but apparently as principal actors, is worthy of observation. In the symbolical groups embroidered on robes, the eunuch is even frequently seen invested with outward attributes of a sacred character. It is possible that youths are meant; or that the priests, forming an exception to the general rule, shaved their beards. However, as far as I can judge, the Assyrians never portrayed a male figure without a beard; and the attendants, or priests, at the fire-altars cannot be distinguished, either by their features or their dress, from the eunuchs of the bas-reliefs. That the Babylonians had an order of priesthood, not only resembling the Magi of the Persians, but even bearing the same name, we learn from the title of one of the principal officers of Nebuchadnezzar, the king of Babylon. † He was the Rab Mag, or chief of the magians; another proof of the Assyrian origin of the Persian system.

The sacred emblems carried by the priests, are principally the fruit, or cone, of the pine, various flowers with three or five blossoms, and the square utensil; which, as I have already remarked, appears to have been of embossed or engraved metal, or of metal carved to represent wicker-work, or sometimes actually of wicker-work. M. Lajard, in an elaborate essay, has shown the connection between the cone of the cypress, and the worship of Venus in the religious systems of the East; ‡ but I hesitate to identify the object held by the winged figures of the Assyrian monuments, with the fruit of that tree, or to assign any emblematical meaning to its shape. It has been suggested that, from its inflammable na-

* One of these altars is now in the Louvre.

† Jeremiah, xxxix. 3.

‡ *Nouvelles Annales de l'Institut Archéologique*, vol. xix.

ture, the fir-cone being an apt emblem of fire, whilst the square vessel held the holy water, the two were introduced into sculptures as typical of the sacred elements. However this may be, it is evident from their constant occurrence on Assyrian monuments, that they were very important objects in religious ceremonies.* Any attempt to explain their use, or their typical meaning, can, at present, be little better than an ingenious speculation.

The flowers on the earlier monuments are either circular with five or more petals, or resemble the Greek honey-suckle.† From the constant introduction of the tree ornamented with them, into groups representing the performance of religious ceremonies, there cannot be a doubt that they were symbolical and were invested with a sacred character. The sacred tree, or tree of life, so universally recognized in Eastern systems of theology, is called to mind, and we are naturally led to refer the traditions connected with it to a common origin.‡ On the later Assyrian monuments, as it has already been observed, the lotus frequently takes the place of the honey-suckle, both as a sacred emblem carried by the winged figures, and as an ornament in architecture and in embroideries. I have attributed this change to a close connection with Egypt.

When the king is represented in the sculptures as engaged

* It will be remembered that Bacchus brought his thyrsus, surmounted by the pine or fir-cone, from the East, when he returned from his Indian expedition. The fan, too, as frequently seen in the Assyrian sculptures, was introduced in the ceremonies connected with his worship, and became a sacred emblem. I am inclined to assign an Assyrian origin to both.

† See woodcuts, page 231.

‡ We have the tree of life of Genesis, and the sacred tree of the Hindhus, with its accompanying figures—a group almost identical with the illustrations of the fall in our old Bibles. The Zoroastrian Homa, or sacred tree, was preserved by the Persians, almost as represented on the Assyrian monuments, until the Arab invasion. M. Lajard (*Recherches sur la Culte du Cypès*, in the *Nouvelles Annales de l'Institut Archéologique*, vol. xix.) has collected all the authorities on the probable connection of this object with the worship of Venus, and of its introduction from Assyria into Asia Minor, Persia, and central Asia, on one side, and into Arabia on the other.

in the performance of some religious ceremony before the sacred tree, or beneath the image of the deity, he appears to be peculiarly attired. His waist is encircled by a kind of knotted zone, the ends of which fall down almost to his feet. Such was probably the girdle with which the Persian disciples of Zoroaster were invested on their initiation. He holds in one hand a mace, formed by a handle terminating in a globe or disk. A similar object is frequently carried by winged figures. It is sometimes replaced by a kind of bident, which appears to be connected by a wavy line with the figure of the divinity above.* Suspended round the king's neck are the sacred emblems, the sun, moon, star, horned cap, and trident.

The intimate connection between the public and private life of the Assyrians and their religion, is abundantly proved by the sculptures described in the previous pages. As amongst most ancient Eastern nations, not only all public and social duties, but even the commonest forms and customs, appear to have been more or less influenced by religion, or to have been looked upon as typical. The residence of the king, as I have observed, was probably at the same time the temple,† and that he himself was either supposed to be invested with divine attributes, or was looked upon as a type of the Supreme Deity, is shown by the sculptures. The winged figures, even that with the head of the eagle, minister to him. All his acts, whether in war or peace, appear to have been connected with the national religion, and were believed to be under the special protection and superintendence of the deity. When he is represented in battle, the winged figure in the circle hovers

* Representations of these objects will be found in my "Monuments of Nineveh."

† The scholiast on the *Periegesis* of Dionysius, already quoted (note, p. 203), observes, with reference to the dedication of a great house to Belus by Semiramis, "She dedicated upon the Acropolis a *great house* to Belus, that is to the king (for this Belus is Jupiter or the son of Jupiter, the king according to the Jews); instead of saying she dedicated or founded a great temple, and beautified and decorated it with gold and silver and ivory; for the expression placed and prepared a palace is couvenable to a king."

above his head, bends the bow against his enemies, or assumes his attitude of triumph. His contests with the lion and other formidable animals, not only show his prowess and skill, but typify, at the same time, his superior strength and wisdom. Whether he has overcome his enemies or the wild beasts, he pours out a libation from the sacred cup, attended by his courtiers, and by the winged figures. The embroideries upon his robes, and upon those of his attendants, have all mythic meanings. Even his weapons, bracelets, and armlets, are adorned with the forms of sacred animals, the lion, bull, or duck. In architectural decorations, the same religious influence is evident. The fir or pine cone, and the honey-suckle, are constantly repeated. They form friezes, the capitals of columns, and the fringes of hangings.* Chairs, tables, and couches, are adorned with the heads and feet of the bull, the lion, and the ram, all sacred animals.† Even on chariots and on the trappings of horses, the Assyrians introduced their religious emblems. This singular connection between religion, and the duties and events of life, whether public or private, so remarkably illustrated by the monuments of the Assyrians and Egyptians, and by the Jewish law, is well worthy of philosophical inquiry. But the subject does not enter into the scope of these volumes.

It only remains for me to say a few words on the mode of

* Note the Ionic form of the capital of the Assyrian pillars already alluded to (p. 216), and the sacred character of the Greek Ionic column, which was exclusively used for funereal purposes. A column of this order stands alone in the centre of the pediment of a tomb at Telmissus.

† The bull has always held a prominent place in the religious systems of Asia. The sacred bull of the Assyrians, the Apis of the Egyptians, and the bull Nandi of the Hindhus, are evidently identical types. The golden calf of the Israelites will not be forgotten, and for the use of the figure of the bull as a sacred ornament by the Jews, the brazen sea in the temple of Solomon may be cited. (1 Kings, vii. 25: 2 Chron. iv. 4, 5; and Jeremiah, lii. 20.) That in Assyria Baal, or the Supreme Deity, was worshipped under the form of a bull or heifer may be inferred from Tobit, i. 5. "Now all the tribes which together revolted, and the house of my father Naphthali, sacrificed unto the heifer Baal;" but the reading is doubtful.

burial of the Assyrians. As I have already observed, no tombs which can with certainty be attributed to that people, have yet been discovered. We may conjecture, as the analogies between the two nations are in other respects so evident, that the Persians imitated the Assyrians, in their funereal ceremonies. The body may have been inclosed in a coffin filled with honey, wax, or oil; and this may also be inferred from the anecdote related by Ælian as to the body of Belus.* Traditions have been preserved relating to the tombs of the two most celebrated Assyrian kings—Ninus and Sardanapalus; but they are so confused and vague, that even the precise place of sepulture of those monarchs cannot be determined. According to some the tomb of Ninus was at Babylon, where, it will be remembered, Ovid places the "Busta Nini;" according to others, at Nineveh. Ctesias relates that when her husband died, Semiramis buried his body in the palace, and raised over it a huge tumulus or pyramid of earth, which was visible from afar, and was still standing after the destruction of the city and the fall of the empire.† From the ambiguous expression of the Greek author it might be inferred, that the palace itself was actually buried. The extraordinary preservation of the sculptures at Nimroud, and the existence of the pyramid, almost induced me at one time to believe that the building had been purposely covered up; and that the part of the mound inclosing the northwest edifice was actually the monument described by Ctesias. Nor can this conjecture be rejected on account of its mere absurdity, when we remember the extraordinary works of those ancient nations, which more

* See note, p. 175. Rich discovered a skeleton in a square wooden box or coffin amongst the ruins of Babylon. Under the head was a round pebble, on the outside of the coffin a brass bird, and in the inside an ornament of the same material, which had probably been suspended to some part of the corpse. But from the position of the coffin, it is doubtful whether it was of the pure Babylonian epoch.

† Diod. Sic. l. ii. Although Ctesias, as usual, has placed Nineveh on the Euphrates, the destruction of the city by the Medes identifies it with the city on the Tigris, and, at the same time, may connect the tumulus he describes with the Nimroud mound.

or less resembled the Assyrians in their customs, and in their political condition. An ancient tradition declares that Ninus neither died, nor was buried, in Assyria; but that, having been dethroned by Semiramis, he fled into Crete.* Semiramis herself is said by some to have been changed into a dove, and to have been honored with an apotheosis; whilst according to others she burnt herself at Babylon, on account of the death of a favorite horse,† an inscription recording her conquest and great works being placed over her tomb.‡

The same doubt exists as to the burial-place of Sardanapalus. Some have placed his tomb at Anchiale, in Cilicia, where it was said to have been seen by Alexander; others at Tarsus; others, again, at Nineveh. According to Amyntus,§ at the gate of the Assyrian capital was a high artificial terrace, or tumulus, which was the tomb of the monarch, and bore an inscription to that effect, in Chaldæan letters. During the siege of Nineveh engines of war, brought against the besieged, were placed upon it. But if this were the tomb of the Sardanapalus of history, who burnt himself, with his wealth and concubines, and after whose death the Assyrian dynasty and capital were totally destroyed, it may be asked how it could have been thus raised in the most conspicuous part of the city? It is most probable that the high terrace described by Amyntus was the pyramid or mound of Nimroud, and the tomb of a much earlier monarch. The epitaph inscribed upon the tomb of Sardanapalus—"Sardanapalus, the son of Anacyndaraxos, built Anchiale and Tarsus in one day: eat, drink,

* *Moses Chor. c. xiv.* Quippe vir ejus (Semiramis) Ninus, non ut fertur, mortuus in Nineves regiâ ab ea sepultus erat, sed ubi impudicitiam ejus ac mores flagitiosos perspicit, relicto regno, in Cretam confugit.

† *Pliny Hist. Nat. l. viii. c. 42.* "Semiramis in Babylonia equo amisso in pyram se conjecit." Mr. Birch suggests to me that the true reading may be, "regno amisso."

‡ *Pollyænus (vii c. 25)* gives the inscription, which, however, may be looked upon as fabulous.

§ *Στραβου. l. 3.*

and lust ; the rest is nothing"—has been quoted for ages, and its authenticity is generally admitted. Yet some versions of the same inscription would give a more favorable view of the character of the monarch ; although the sentiment, according to those who pretend to have seen the monument, was sufficiently illustrated by a statue, representing the king snapping his fingers in contempt, or in the attitude of a dancer.*

The manner of the death of Sardanapalus is no less doubtful than the site of his tomb. The Assyrian king, upon the funeral pile, surrounded by his wives, his concubines, and his treasures of gold and silver, gazing from the flaming heap on the great city, once impregnable, and now to become the prey of the conquering Mede, has long been a favorite theme of the poet, the historian, and the moralist. Some, however, pretend that the monarch, driven from his throne, and the victim of

* Various versions of this celebrated epitaph have been handed down to us. Athenæus gives three (lib. viii.) ; one by the poet Cherillus, in seven hexameter verses, from the works of Chrysippus ; a second, by the poet Phœnix, of Colophon, containing fourteen verses, with a preamble of eleven ; and a third from Amyntas, all in the same sense. Note that Sardanapalus is called Ninus in one of these versions. According to Clearchus, a disciple of Aristotle, the epitaph was merely "Sardanapalus, the son of Anacyndaraxos, built the cities of Tarsus and Anchiale in one day. He is now dead." Thus inferring the vanity of human power and greatness. The concluding words in the text, which convey the condemnatory sentiment, were added. (*Essai sur l'Histoire, &c., des Assyriens de Ninive*, by Freret, in the *Memoires of the Académie Royale des Inscriptions, &c.*, from 1718 to 1725.) With regard to the form of the tomb itself, as represented on the imperial coins of Anchiale, it may be presumed that it is merely conjectural, or that it was derived from an ancient monument restored at a later period. Still there is something Assyrian both in the design and in the figures placed upon it. It consisted of a kind of pyramid, surmounted by an eagle, having in front an Assyrian god, holding a cone, and trampling on a sphinx. Two winged figures stood on the wall, or peribole, surrounding the pyramid. A massive ruin of stone and brick-work—consisting of a square base, surrounded by a wall of great thickness—in the midst of the modern town of Tarsus, has been by some identified with the tomb of Sardanapalus. This ruin was opened in one or two places some years ago by the French consul, but without results of any interest. The whole appears to be a solid mass of masonry, and was probably only the lower part of a monument, perhaps originally cased with marble.

luxury and debauch, wandered into a distant part of his former dominions, and died of premature old age.* Others, again, as it has been seen, place his tomb at Anchiãle, with an inscription only becoming one who had died a monarch. Modern critics, at a loss to reconcile these anomalies regarding Ninus, Semiramis, and Sardanapalus, have been compelled to assume that there were two or more monarchs of each name; whose deeds and the period of whose existence have been confounded by ancient historians.†

But if an impenetrable mystery surrounds the lives of

* Athenæus, lib. xii. And yet he gives, at the same time, a full account of his death on the funeral pile, which was burning for fifteen days—every one, excepting an eunuch who was within the palace, believing that the king was offering up a great sacrifice.

† "Sardanapalus" may have been a title; or sardan, a title or name, and pal, great; as frequently conjectured. Atossa bore the name of Semiramis (Euseb. Chron.), and many of her works were attributed to the earlier queen. The arguments of Bryant (*Mythology*, vol. ii. p. 100) to prove that the name of Semiramis attached to a tribe or nation, typified, according to a very common Eastern custom, by an individual, are ingenious. A Semiramis of history was invested with a semi-sacred character. She was the daughter of a Syrian goddess, half fish, and a young man of the country. Being exposed at her birth, she was brought up by birds, and was ultimately transformed into a dove. From her mother, the Syrians worshipped the fish, and from her own apotheosis the dove became a sacred symbol amongst the Assyrians; whilst her name was supposed to denote that bird. Fabulous and legendary as these accounts are, they appear to have had an origin in Assyrian rites only understood by the initiated, and whose mythic meaning had perished altogether before they were described. The dove appears to have been an Assyrian emblem. Yet we have no representation of it in the sculptures, unless it be the bird carried by the warriors, which I have been inclined to identify with the *Iyngea*. (Note, p. 350.) Mr. Birch has pointed out in his *Memoir on the Nimroud Cartouches* (p. 160), the coincidence of the name of the first husband of Semiramis, Onnes, with that of the Chaldean sea god, Oannes. The legendary accounts of the queen go far to connect her with Astarte and Venus. A scholiast, on the *Periegesis* of Dionysius, makes her the same as the goddess Artemis or Dispoïna. Note also the Assyrian and Syrian origin of Adonis, and the legends connected with him. The authorities on the worship of Astarte and Derceto are collected by Selden (*de Diis Syriis*, c. 3). With regard to the historical Semiramis, the confusion as to the time of her existence, her deeds, and her connection with Ninus, is equally inexplicable. She is declared to be the wife, daughter, and even the mother, or step-mother, of that monarch. (Cramer, *Anecdota Græca*, vol. ii. p. 170.)

kings who were connected with the greatest revolutions and political changes in Asia, how can we hope to determine the precise mode and place of their burial? If this obscurity hangs over the deeds of the three greatest characters in Assyrian history, how fruitless would be an endeavor to frame a narrative of any minor events, from the materials hitherto accessible! Although the ancients were unable to discover the records of more than thirty generations of kings, we cannot concur in their sweeping assertion that the lives of those monarchs were passed in inglorious sloth, and that their reigns were unmarked by a single achievement worthy of notice. These writers contradict themselves when they speak of the Assyrian power extending from India to the Hellespont, and the name of Assyria applying to a region stretching from the confines of Pontus to the borders of Egypt. History may have failed to chronicle the deeds of a nation which could maintain its sway over the largest portion of the then civilized world, and traditions, in which their remembrance was preserved, may have perished before history was ready to receive them; but the records of the people themselves have remained, and are now before us. From them we may hope to fill up a part of a great blank in the history of the world. The attempt to do so cannot be altogether uninteresting or unimportant. It is of Assyria we treat,—a name familiar to us as the seat of the earliest settlements of the human race, and as the birth-place of the first patriarchs. How far the civilization and worship of its inhabitants may have affected a religious system, which still maintains an influence over nearly one half of the human race, we are not yet, probably, fully aware; nor could I, at present, venture to inquire. A more palpable influence exercised over Asia Minor, and even Greece, has been casually, though imperfectly, pointed out in these volumes.* I might further enlarge on the diffusion of the arts and religion of the

* "In the time of the twelve patriarchs was Hesiod, who translated Assyrian writings into Greek." (*Anecd. Græca*, Cramer, vol. ii. p. 389.)

Assyrians, either directly or through their allies, over the distant regions of Egypt and Libya. Engaging theories, not devoid of plausibility, might be advanced, and at any rate an extended and impartial inquiry might convince us that the influence of Assyria was more extensive than a mere superficial examination might lead us to suspect. But such subjects are at present out of my province. I shall be well satisfied, and my literary labors, as well as those of a more active nature, will be amply rewarded, if I have succeeded in an attempt to add a page to the history of mankind, by restoring a part of the lost annals of Assyria.

INDEX.

A

- Abd'rubbou*, sheikh of the Jebour, i. 87.
Abd-ul-Summit Bey, i. 149, 151.
Abd-ur-rahman, sheikh of the Abou Salman, i. 65, 112; ii. 70.
Abou-Salman Arabs, encampment of, i. 65.
Abou-Maria, village of, i. 256
Abraham and Nimrod, story of, i. 42.
Abydenus, his list of Assyrian kings, ii. 183.
Acacius, archbishop of Seleucia, i. 204.
Agron, king of Lydia, son of Ninus, ii. 180
Ahmed Pasha, name on slab at Nimroud, i. 46.
Alabaster, vases of, discovered, i. 279. Tablets of, i. 110. Used in buildings, ii. 201, 244.
Al Hather, visit to ruins of, i. 85, 105.
Al Kosh, village of, i. 197. Tomb of Nahum at, 197.
Altars, Assyrian, ii. 354. The tripod, 355.
Amadiyah, the town of, i. 141.
American missions to the Chaldeans, i. 224.
Amsha, the wife of Sofuk, i. 98.
Animals embroidered on robes, ii. 249, and *note*.
Antelope on obelisk, ii. 435.
Antimony found in Assyria, ii. 319.
Apollo confounded with Belus, ii. *note*, 341.
Apollo called Gryphenias, ii. 349, *note*.
Arabs—Family, i. 41. Life-charms of, 82. Repast, 89. Beauty, 99. Dances, 113. Workmen, 271. Women, 291. Mode of life, 292. Protect the Chaldeans, 208. Encampment of, ii. 43.
Arch known to Assyrians, i. 167; ii. 205.
Archers, Assyrian, their dress, ii. 261.
Architecture, Assyrian, ii. 197. No remains of exterior, 211.
Aristotle, works of, translated by Chaldeans, i. 209.
Armenia, rock tablets of, ii. 142.
Armor, Assyrian, discovered at Nimroud, i. 278. In sculptures, ii. 260.
Arms of king, ii. 250. Of Warriors, 265.
Army, description of Persian, ii. 279. Of Assyrian, 279.
Artaxerxes, ii. 235, *note*.
Arts, state of, amongst Assyrians, ii. 220.
Asheetha, village of, i. 153. Church at, 157.
Asia Minor, influence of Assyria on, ii. 225. Assyrian descent of nations of, 226, *note*.
Asoka, ornament on monument of, ii. 231.
Ass not represented on Assyrian monuments, ii. 323.
Asses, wild, i. 265, and *note*.
Assyria, nature of ruins of, i. 29. Ancient population of, 53. Origin of Christianity in, 204. Writing of, ii. 131, 142. Antiquity of, 176. Language and race of inhabitants, 187. Fertility of, 320. Name of, on Egyptian monuments, 308.
Astarte, or Venus, her worship, ii. 168, 345.
Astronomy, science of, amongst the Chaldees, ii. 337.
Astyages, king, his dress, ii. *note*, 250.
Athur, name of Assyrian deity, ii. 168. Name in inscription, 181, and *note*; 182. Ruins of Nimroud so called, ii. 194, and *note*.

Aubnura, name in cartouche from Nimroud, ii. 166.

B

Baal, the Assyrian deity, ii. 188, 341.
Babylon, true site of, ii. 139. Obelisk at, *note*, 139, 171. Cuneiform writing of, 137. Description of, 263, *note*. Walls of, 218.
Bacchus, Assyrian origin of his thyrsus, ii. 356.
Basalt, figures in, not painted, ii. 238. Used in monuments, 245.
Basheikhah, fragments of sculpture discovered at, i. 63.
Bas-reliefs, first discovery of, i. 54. Sent to Baghdad, 283.
Battering-ram in sculptures, i. 120, 275; ii. 27. The Assyrian, 281, 284.
Bavian, rock-tablets at, i. 196; ii. *note*, 114.
Baz, district of, i. 180.
Be-Alatha, village of, i. 184.
Bebozi, Chaldean village of, i. 139.
Beder Khan Bey, i. *note*, 153. Banished to Candia, 202.
Bekistun, inscription at, deciphered, ii. 135.
Belled Sinjar, ruins at, i. 264.
Belus, the temple of, vaulted rooms in, ii. 205, *note*. Idols in the temple, 352. Statue of, at Babylon, 342.
Berosus, his Chaldean history, ii. *note*, 176.
Birch, Mr., his description of the ivory ornaments, ii. *note*, 16. His remarks on ivories, 163, 168.
Birjai, village of, i. 171.
Birds in Assyrian sculptures, ii. 331.
Bit of horses, ii. 274.
Bitumen under pavement, i. 46. Employed as cement, ii. 219.
Blue, Assyrian, ii. 241.
Botta, M., his excavations, ii. 14, 20.
Bows, Assyrian, ii. 234, 263.
Bracelets, Assyrian, i. 125. Worn by king, ii. 250.
Breastplates, Assyrian, ii. 234.
Bricks, inscriptions on, ii. 147, 149. Invention of, 200. Painted, 243.
Bull, human-headed, discovery of, i. 60. Removal of, ii. 68. On Assyrian ornaments, 232. A sacred

type, 350, 358, *note*. The wild, 326. On obelisk, 330.

Burial, mode of, amongst Assyrians, ii. 358.

C

Cadi, the, of Mosul, i. 48.
Caillou, de Michaud, ii. 144.
Camel in Assyrian sculptures, ii. 427. Bactrian, on obelisk, 329.
Canning, Sir Stratford, undertakes excavations, i. 36, 121, 267.
Carpets, Assyrian and Babylonian, ii. 314.
Cart represented in a bas-relief, ii. 301.
Castor, his Assyrian chronology, ii. 172.
Cavalry in Assyrian armies, ii. 274.
Ceiling of Assyrian chambers, how formed, ii. 204, 208, 209, *note*.
Chaldeans of Kurdistan, origin of, i. 203. Extent of their early missions, 205. Learning of, 208. Their patriarchs, 215. Their doctrines, 218. Their language, 223.
Chaldeans, ancient, of Babylonia, their language and origin, ii. 188. Their religion, 336. Their astronomy, 338.
Chairs in Assyrian bas-reliefs, ii. 234.
Charcoal found in ruins, i. 47.
Chariots, Assyrian, ii. 268.
Chase, the, ii. 328.
Chebar, a river of Assyria, ii. 240.
China, Chaldean missions in, i. 205.
Cidaris of the Persian kings, ii. 249.
Circle, winged emblem of the divinity, ii. 339.
Clinton, his Assyrian chronology, ii. 129, 172.
Coins, not known to Assyrians, ii. 318.
Colors, used by Assyrians on walls, i. 121. On sculptures, ii. 238, 241. Their nature, *ib*.
Column, the, not known to Assyrians, ii. 215. Ionic origin of, 216. At Persepolis, 228.
Copper ornaments discovered at Nimroud, i. 110. Mines of, in the Tiyari mountains, 189. Discovery of vessels in, ii. 16. Extensive use of, by Assyrians, 318.
Cor, found in names on coast of Asia Minor, ii. *note*, 295.
Corn produced in Assyria, ii. 320.

Cotton manufactured in Assyria, ii. 314.
Cruz ansata, in Assyrian monuments, ii. 170.
Cuneiform writing, nature of, ii. 131, 134, 138. Origin of, 142.
Cups, Assyrian forms of, ii. 236.
Cup-bearer, office of, ii. 253.
Cursive writing of Assyrians, ii. 131, 133.
Cylinders, inscriptions on, ii. 147.
Cyrus, the tomb of, ii. 227.

D

Daggers, Assyrian forms of, ii. 234. Always carried by Assyrians, 264.
Dagon, the fish-god, ii. note, 353.
Dam across Tigris at Nimroud, i. 30.
Daniel, tomb of, i. 212.
Daoud Agha, i. 53.
Darius, his dress, ii. note, 250.
Darics, first Persian coins, ii. 318.
Dathan, an Arab, i. 103.
Desert, the, i. 87.
Devil, Yezedis' respect for the, i. 246.
Diodorus Siculus, his Assyrian chronology, ii. 172. His description of Babylon, 342.
Divorce amongst Arabs, i. 288.
Dog on Assyrian monuments, ii. 323.
Dohuk, village of, i. 194.
Dove, the, an Assyrian emblem, ii. note, 362.
Drain in Assyrian edifice, i. 123 ; ii. 67, 206.
Ducks, in baked clay, discovered, i. 110. In marble, ii. 245.
Dyes, Assyrian, ii. 242. For the hair, 254 ; art of dying, 313.

E

Eagles represented in sculptures, ii. 331. Symbol of triumph, ii. 331.
Eagle-headed figure, discovery of, i. 71 ; ii. 349.
Ear-rings, Assyrian, ii. 234. Worn by king, 250.
Ecbatana, walls of, ii. 216.
Edessa, school of, i. 204.
Egyptian symbols at Nimroud, i. 47. Connection with Assyria, ii. 163. Names on monuments identified with enemies of the Assyrians, 308.

Elephant, its tusks represented in sculptures, i. 120. On obelisk, ii. 329. Not used by Egyptians, 330, note.
Embroideries, Assyrian, on robes, ii. 313.
Enamelling on bricks, ii. 243.
Enemies of the Assyrians, ii. 298.
Ergub, village of, i. 180.
Essad Pasha, ii. 10.
Ethiopians, or Kushites, ii. 171, note.
Eunuchs, their offices in Assyrian court, ii. 325. Officiate in religious ceremonies, 355.
Eusebius, his Assyrian chronology, ii. 172.
Evorita, palace of, ii. 173, note, 196.
Excavating, mode of, ii. 97.
Ezekiel, his description of the Assyrian palaces, ii. 239. Of the fall of Nineveh, 240. Vision of, illustrated, 351.

F

Fan in worship of Bacchus of Assyrian origin, ii. 356.
Female divinities in Assyrian sculptures, ii. 351.
Ferhan, son of Sofuk, i. 92.
Festivals, public, magnificence of, ii. 312.
Fir-cone, the, a sacred emblem, ii. 356.
Fire-worship of Assyrians, ii. 354. Origin of, 335, note.
Fish represented in Assyrian sculptures, i. 55 ; ii. 332. Worship of, amongst Assyrians, 353.
Flowers, sacred, of Assyrians, ii. 233, 356.
Footstools, ii. 236.
Furniture, ii. 234.

G

Galleys in Assyrian bas-reliefs, ii. 293.
Garments, Assyrian, 248.
Gates to Assyrian edifices, ii. 273.
Gems, engraving on, ii. 320.
Gilding, art of, known to Assyrians, ii. 317.
Girdle, sacred, worn by king, ii. 357.
Glass, manufacture of, ii. 320.
Globe, winged, an Assyrian emblem, ii. 448.
Goat, on ornaments, ii. 232. On bas-reliefs, 323-4. The wild, 327.

Gods, Assyrian, connected with Egyptian, ii. 168. Carried in procession, 451.
Gold, use of, in architecture, ii. 209, and *note*. Abundance of, in Assyria, 316, 317.
Gold-leaf discovered, i. 47. Under altar, 124.
Grant, Dr., i. 157, *note*.
Gryphon, the, an Assyrian emblem, ii. 349.
Guilloche, the, an Assyrian ornament, ii. 233.

H

Haddadeen Arabs, i. 87.
Hair, mode of dressing the, ii. 254.
Halicarnassus, sculptures from, i. 37. *note*.
Hammum Ali, village of, i. 27.
Harness, Assyrian, ii. 234, 272.
Harry tomb from Xanthus, ii. 230.
Hatchet carried by Assyrian warriors, ii. 265.
Helmets in bas-reliefs, i. 55. With curved crest, 69. Discovery of, at Nimroud, 278. Various forms of, ii. 261. Material of, 318.
Hera, her statue at Babylon, ii. 342. The Assyrian Venus, 345.
Hincks, Dr., on cuneiform character, ii. 158.
Honeysuckle ornament of Assyrian origin, ii. 231.
Horus an Assyrian king, ii. 171.
Horses, furniture of, ii. 273, 276. In chariots, 274. Breed of, in Assyria, 276. Dedicated to the sun, 280. Winged and sacred emblem, 350.
Horsemen in Assyrian armies, ii. 130.
Houses of Baghdad and Mosul, i. 130. Assyrian, ii. 212.
Human remains, discovery of, ii. 18.
Hunting favored by Assyrians, ii. 328.
Hussein Bey, the chief of the Yezidis, i. 227.
Hytas or irregular cavalry, i. 53, *note*.

I

Ibez. See Wild Goat.
Ibrahim Agha, i. 97, 185.
Idols in bas-reliefs, ii. 342. Made of gold and precious metals 344.

Impalement of prisoners, ii. 286.
Indo-European races, their characteristics, ii. 189.
Inlaying, art of, known to Assyrians, ii. 319.
Inscriptions at Nimroud, i. 56. Importance of, ii. 131.
Ionic column, Assyrian origin of, ii. 216. Order sacred, 358, *note*.
Iron discovered at Nimroud, i. 278. Mines of, in Kurdistan, 189. Used by Assyrians, ii. 318.
Irrigation, mode of, in Assyria, i. 287; ii. 321.
Ismail Pasha, of Mosul, i. 61. Of Amadiyah, 144.
Ismail Agha, i. 145.
Ivory ornaments, discovery of, i. 47. Description of, ii. 15. Date of, 163. 168. Carving in, 319.
Iyngees, or sacred birds, ii. 350, *note*.

J

Jebour Arabs, i. 78.
Jeraiyah, mound of, i. 50.
Jeremy, epistle of, ii. 343.
Jews, their office in Assyrian court, ii. 259, *note*. Not represented in Assyrian bas-reliefs, ii. 302.
Jonah, tomb of, ii. 192.

K

Kalah Sherghat, ruins of, i. 28. Visit to, ii. 42. Discoveries at, 45.
Kaloni, village of, i. 118.
Karamles, ruins at, i. 63.
Kasha Bodaca, i. 176.
Kasha Kana, i. 160.
Kasha Auraham, i. 189.
Kel-i-Shin, inscription at, ii. 146.
Ken, the Assyrian Venus, ii. 160.
Khauser, the, a stream near Konyunjik, ii. 96.
Khita, the, of Egyptian monuments, ii. 306.
Khorsabad, M. Botta's discovery of, i. 32. Visit to, 136. Name of king on monuments of, ii. 158.
Khouara mountain, i. 183.
Kings, the, in sculptures, i. 68, 120, 276. Names of Assyrian, ii. 20, 154, 159. In Egyptian dynasties, 165. Their

names on monuments, 210. Robes of Assyrian, 233. Present in battle, 279. During siege, 285. During religious ceremonies, 356. Their sacred character, 357.

Kiyara, the, or bitumen pits, ii. 43.

Kouyunjik, first excavations at, i. 31, 122. Sculptures of 131. Excavations at, ii. 96. Description of ruins, 98, 101. Interesting relic discovered by Mr. Ross, 112. Name of king on monuments of, 100, 158. Part of Nineveh, 197.

Kurdish chief, i. 78. Women, 98. Activity of, 165.

Kuremi, village of, i. 192.

Kushites, the, or Ethiopians, ii. 171.

Kussel el Nimroud, an Arabic work, i. 43, *note*.

L

Ladders used in sieges, ii. 285.

Ladies, Shammar, description of, i. 101.

Lariasa identified with Nimroud, i. 27; ii. 128, *note*.

Leather, writings on, ii. 149.

Letters, invention of, ii. 132.

Limestone used in Assyrian buildings, ii. 244. Bulls in yellow, 245.

Lion, crouching, in basalt, i. 60. Winged, 72. In copper, discovered, 119. King hunting, in bas-relief, 120. Found in Mesopotamia, ii. 44. Removal of winged, 76. Human-headed, 105, 350. Figure of, in Assyrian ornaments, 235. In bas-reliefs, 326. Human figure, with head of, 352.

Lizan, village of, i. 163. Massacre at, 164.

Longworth, Mr., his account of Nimroud, i. 298. His conjectures as to exterior architecture, 213, *note*.

Lotus introduced as an ornament, ii. 356.

Lydians, Assyrian descent of, ii. 181, 225.

M

Mace carried by Assyrian warriors, ii. 264.

Machines used in sieges, ii. 284.

Magi amongst Assyrians, ii. 355.

Malabar, historians of, i. 216.

Malta Times, letters on Khorsabad in, i. 36, *note*.

Malthaiyah, rock-sculptures at, i. 195.

Manacles, iron, on prisoners, ii. 287-8.

Marble, white and black, in Assyrian edifices, ii. 245.

Mar-Elias, monastery of, i. 86.

Manufactures, Assyrian, ii. 313.

Mars confounded with Belus, ii. 352, *note*.

Mar Shamoun, patriarch of the Chaldeans, i. 134, *note* 188.

Marth d' Kasra, village of, i. 186.

Mechanics, knowledge of, amongst Assyrians, ii. 246.

Median, cuneiform writing so called, ii. 134, 136.

Mediterranean, Assyrian empire extended to, ii. 115.

Melek Ismail, death of, i. 187.

Memnon, confusion respecting, ii. 171, *note*. Present at siege of Troy, 226.

Meru. Chaldean metropolitan at, i. 213.

Mesopotamia, the spring in, i. 81. The Naharaina of the Egyptians, ii. 181, *note*.

Mespila, identified with Kouyunjik, ii. 196, 218, *note*. Walls of, 218.

Metals, Assyrians skilled in working in, ii. 315, 317.

Metropolitans, list of Chaldean, i. 214.

Military pomp of Assyrians, ii. 279.

Mirkan, Yezidi, village of, i. 259.

Minianish, village of, i. 163.

Missionaries, American, i. 224.

Missouri, Kurdish tribes of, i. 137.

Mohammed, pasha of Mosul, i. 39, 48. Disgrace of, 61.

Mohammed Agha, i. 269.

Mohammed, the prophet, borrows from the Chaldeans, i. 207. His treaty with them, 207 and *note*.

Money, not known to Assyrians, ii. 318.

Mongolian, characteristics of the race, ii. 190.

Monkeys, represented in bas-reliefs, i. 118. On obelisks, ii. 331.

Moon, the, an Assyrian emblem, ii. 338.

Moses of Chorene, his account of Ninus, ii. 183, *note*.

Mosul, arrival at, i. 38. Bridge of boats at, ii. 76.

Mule, the, in Assyrian bas-reliefs, ii. 323.

Mullah Ali, a Kurdish chief, i. 78.

Museum, British, undertakes excavations, i. 267. Arrangement of sculptures in, ii. 228, *note*.

Musical instruments, ii. 313.

Musicians represented in bas-reliefs, i. 273.

Mutesellim, a Kurdish chief, i. 177.

N

Naharaina, or Mesopotamia, ii. 179, 188, *note*.

Nahar-el-Kelb, Assyrian bas-relief at, ii. 115, 145, 304, *note*.

Nahum, tomb of, i. 197.

Naifa, village of, i. 44.

Names written over persons or objects in bas-reliefs, ii. 210.

Nasr, Sheikh, i. 233. His letter to the Yezidis of Sinjar, 253-4.

Nebbi Yunus, ruins in the mound of, ii. 171.

Nebuchadnezzar, his name on Babylonian remains, ii. 138, 139.

Necklace worn by Assyrians, ii. 250.

Negoub, tunnel of and inscription at, i. 84. Names of kings in inscription from, ii. 159.

Negroes, doubtful whether represented in Assyrian bas-reliefs, ii. 303.

Nektar from Assyria, ii. 323, *note*.

Nejiris, sheikh of the Shammar, i. 94, 106. His murder, 108.

Nestorius, his history, i. 204.

Nestorians, massacre of, i. 157. Origin of their name, 117. Their doctrines, 218. * See Chaldeans.

Nicolaus of Damascus, story of Parsondes, ii. 255.

Niffer, ruins at, represent ancient Babylon, ii. 138. Name on bricks from, 141.

Nimrod, story of, i. 30, 42. Supposed discovery of, 72.

Nimroud, first sight of, i. 28. Revisited, 29. First discoveries at, 44. Discovery of northwest palace, 71. Build house at, 270. Daily occupations at, 295. Departure from, ii. 95. Inscriptions from, 154, 157.

Nineveh, date of destruction of, ii. 129,

163. Named in the Karnak tablet, 178. True site of, 194. Extent of, 194.

Ninus, confounded with Noah and Nimrod, ii. 177. First king of Assyria according to some, 177 and *note*. Name of in inscriptions, 181. May have overthrown an earlier dynasty, 224. Introduced fire-worship, 335 *note*. His death and tomb, 359.

Ninus the Second, ii. 183.

Ninyas, the son of Ninus, ii. 153.

Nisroch, the eagle-headed god, ii. 348.

Nitocris, her buildings at Babylon, ii. 140.

Numerals, Assyrian, ii. 132, *note*.

Nymphs, Assyrian rock-sculpture at, ii. 225, and *note*.

O

Oannes, the fish-god, ii. 166, 353.

Obelisk, discovery of, i. 282. Inscription on, ii. 152. Description of animals on, 329. An obelisk at Babylon, 138, 179, *note*.

Oil of sesame used by Assyrians, ii. 321.

Onnes, the first husband of Semiramis, ii. 362, *note*.

Ormuzd, the Persian symbol of, ii. 441.

Ornaments, Assyrian, of a late period, ii. 238.

Ostrich, a sacred bird, ii. 331.

Ourmeli, subashi of, i. 191.

P

Paint, on sculptures, i. 71. On walls of chambers, ii, 17. On bricks, 17, 18. On bas-relief, 238.

Palace, description of an Assyrian, ii. 207. Also temples, 211.

Palm-tree, the, in bas-reliefs, ii. 110, 301, 304. Grown in Assyria, 322. Wine made of the fruit, 323.

Palou, inscription at, ii. 137.

Papyrus used in Assyria, ii. 147.

Paradises, or Parka, of Assyrians, ii. 328.

Parsondes, history of, ii. 255.

Parthians, mode of discharging their arrows, ii. 299, 300, *note*.

Patriarch, the Chaldeans, i. 265.
Pavement of bricks, i. 111. Of the chambers of Assyrian palaces, ii. 206.
Pegasus, the, an Assyrian emblem, ii. 350.
Persepolis, Assyrian origin of sculptures of, ii. 227. Of religious emblems at, 335.
Persia, cuneiform writing of, ii. 136. Names of kings of, on vases, 129, *note*. Influence of in Asia Minor, 225.
Perseus, his Assyrian origin, ii. 335, *note*.
Phalanz, known to Assyrians, ii. 268.
Pillars, inscriptions on, ii. 146.
Pine-cone, the, a sacred emblem, ii. 355.
Pleiads, the, on Assyrian monuments, ii. 346.
Plough, the, used in Assyria, ii. 321.
Polyhistor, his Assyrian chronology, ii. 172.
Pottery, in tombs at Nimroud, ii. 173.
Prestor John, i. 209. His letter to the Greek emperor, 210.
Pomegranate, the, a sacred emblem, ii. 233.
Priam, dependent on the king of Assyria, ii. 181.
Prisoners, treatment of by Assyrians, ii. 287.
Pritchard, Dr., his observation on the Syro-Arabian races, ii. 191, *note*.
Pterium, rock sculptures at, ii. 225. Winged circle at, 340.
Pul, king of Assyria, ii. 177, *note*.
Pulley, represented in bas-relief, ii. 31, 246.

Q

Quintus Curtius, his description of a Persian army, i. 279.
Quiver of the Assyrians, ii. 234.

R

Rabban Hormuzd, convent of, i. 198.
Rafts, how constructed, ii. 80.
Raola, district of, i. 167.
Rassam, Mr., vice-consul at Mosul, i. 40, 153. Mr. Hormuzd, 64.
Rawlinson, Major, resident at Baghdad,

i. 61. His classification of cuneiform writing, ii. 136.
Records, mode of keeping in ancient Assyria, ii. 147.
Religion of the Assyrians, ii. 333. Connected with their public and private life, 357.
Rhea, her statue at Babylon, ii. 342. Her worship, 347.
Rhinoceros, on obelisk, ii. 330.
River, army crossing a, i. 275.
Robes of the Assyrians, embroideries on, ii. 233. Materials of, 249. Magnificence of, 314.
Rome, church of, persecutes the Nestorians, i. 216.
Roof of Assyrian edifices, how formed, ii. 203, 209, *note*.
Ross, Mr., i. 41, *note*. Carries on excavations at Kouyunjik, ii. 110, 112. His account of Bavian, 114.
Ruten-nu, the, of the Egyptian monuments, who, ii. 308.

S

Sabæanism of the Assyrians, ii. 333.
Saddles not represented in early bas-reliefs, ii. 274.
Saint, a Kurdish, i. 192.
Sandals of the Assyrians, ii. 251.
Saracus, the last king of Assyria, ii. 173.
Sarcophagus, discovery of, i. 286.
Sardanapalus, his effeminacy, ii. 258, *note*. His death and tomb, 359, 360. More than one king of the name, 362, and *note*.
Scribes, represented in bas-reliefs, ii. 146.
Sculptures, method of removing, i. 128. Subjects recorded by, ii. 24. Skill of the Assyrians in the art of sculpture, 221.
Scythians, their language in the cuneiform writing, ii. 134, *note*. Their occupation of Assyria, 162. Characteristics of the race, 190.
Seals, Assyrian, ii. 320.
Se-gan-foo, inscription of, i. 205, 206, *note*.
Selamiyah, village of, i. 51.
Semiramis, account of her edifices, fabulous, ii. 140. Ruins attributed to her,

- 173, *note*. Invention of ship-building attributed to her, 292. Introduces worship of Venus, 345. Her death and tomb, 359. More than one of the name, 362, *note*.
- Semitic* races, their characteristics, ii. 187.
- Sethos*, an Assyrian king, ii. 171.
- Seyyid*, visit to a, ii. 46.
- Shairetana*, the, of Egyptian monuments, ii. 307.
- Shammar*, the, Arabs' description of, i. 90.
- Sharu*, the, of Egyptian monuments, ii. 306.
- Shawls* represented in sculptures, i. 120.
- Sheeas*, the, peculiar doctrines of, i. 80. *note*.
- Sheep* represented in Assyrian bas-reliefs, ii. 324.
- Shetah*, the, of the Egyptian monuments, ii. 303.
- Sheikh Adi*, tomb of, i. 137.
- Sheikh Nasr*. See *Nasr*.
- Sheikh Shems*, sanctuary of, i. 239.
- Sheikh*, seizure of an Arab, i. 196.
- Shields* of the Assyrians, ii. 265. Hung on walls and ships, 296.
- Ships* in sculptures, ii. 104, 290, 293. Of Tyre, 295, 296.
- Siege* represented in bas-relief, i. 55, 260. Description of a, ii. 289.
- Silver* used in roofs, ii. 208. Abundant in Assyria, 317.
- Sinjar*, visit to, i. 254. Ruined town of, 264.
- Skins*, mode of crossing river on, i. 120; ii. 291. Men dressed in, ii. 302.
- Slabs* sculptured after placed, ii. 130.
- Slingers*, Assyrian, ii. 261, 265.
- Sofuk*, sheikh of the Shammar, visit to, i. 91. His history, 93. His domestic establishment, 98. His mare, 100. His death, 108.
- Soil*, fertility of, in Assyria, ii. 56.
- Spears*, Assyrian, ii. 264.
- Sphinx* discovered, i. 283. The Assyrian, ii. 172, 348. On architectural monuments in palaces, 207, and *note*.
- Stamp* used to impress inscriptions, ii. 149.
- Standards*, Assyrian, ii. 268.
- Stars*, worship of, i. 333, *note*, ii. 335, 336, 346-7.
- Steel* probably known to Assyrians, ii. 318.
- Stone*, inscription on, ii. 150.
- Storms*, violence of, i. 116.
- Sugar-cane* formerly cultivated in Assyria, ii. 322.
- Sun*, Yezidi veneration for, i. 240, 247. An Assyrian emblem, ii. 338. Same as Baal, 341, *note*.
- Swimming*, mode of, in Assyria, i. 120.
- Swords*, Assyrian, ii. 234.
- Symbols* suspended round neck of king, i. 123; ii. 338.

T

- Tables*, Assyrian, ii. 236.
- Tablets* on rocks, ii. 145.
- Tahyar Pasha*, i. 115. Visit from, 129. His death, ii. 9.
- Tamerlane* persecutes the Chaldeans, i. 215.
- Tartars*, Nestorian mission to the, i. 209, 212.
- Taurus*, Darius's column on the, ii. 145.
- Tel Afer*, town of, i. 257.
- Tel Kef*, village of, i. 200.
- Temples*, the residence of the king, ii. 211, 357.
- Tents*, in bas-reliefs, ii. 214. In common use amongst Assyrians, 215. Magnificence of Assyrian, 279.
- Teutames*, king of Assyria, sends aid to Troy, ii. 180.
- Throne* of Assyrian king, i. 125; ii. 235.
- Thurus*, king of Assyria, ii. 171, *note*.
- Thyrus* of Bacchus of Assyrian origin, ii. 356.
- Tiara* worn by Assyrian king, ii. 249.
- Tiles*, inscription on, ii. 147.
- Tin* not found in Assyria, ii. 319.
- Tiyari*, departure for the, i. 134. Dress of, 168. Employed in the excavations, 294.
- Tkhoma*, district of, i. 175. Massacre of inhabitants of, 201.
- Tokari*, the, of Egyptian monuments, ii. 307.
- Tombs*, discovery of, ii. 21. Assyrian, not discovered, 124. At Nimroud, 175. Of Persian kings, ib.
- Tools* of copper, ii. 318.
- Towers*, Assyrian, ii. 212. Artificial, used in sieges, 284.
- Tree*, the sacred, ii. 233. In Assyrian sculptures, 332. Of life, 356.

Tribute brought by conquered nations, ii. 303.
Tripod discovered at Khorsabad, i. 135 ; ii. 353.
Troops, disciplined, of the Assyrians, ii. 259-60.
Troy, an Assyrian dependency, ii. 180.
Tunnel under the Euphrates attributed to Semiramis, ii. 205, *note*.
Type, cuneiform, ii. 154.
Tyre, Assyrian conquest of, ii. 116, 304.

U.

Umbrella carried over king, ii. 107, 253.
Unicorn, the, ii. 326.
Ur of the Chaldees, its site, ii. 188, *note*.

V.

Variants in cuneiform inscriptions, ii. 151, 182, *note*.
Vases in glass and alabaster discovered at Nimroud, i. 279. From tombs at Nimroud, ii. 174. Assyrian, 236, 317.
Vault known to the Assyrians, ii. 205.
Venus, the worship of in Assyria, ii. 345.
Vessel, square, carried by winged figures, ii. 357.
Vine, the, grows in Assyria, ii. 323.
Vizir, dress of, ii. 253.
Vizirial letter, arrival of, i. 121.
Vulture, the, represented in Assyrian sculptures, ii. 331.

W.

Walls of Assyrian palaces, ii. 212. Of Nineveh and Babylon, 213, 217, 218, *note*.

Warriors, costume of Assyrian, ii. 260.
Wedge, the, a sacred emblem, ii. 144.
Wigs worn by the Assyrians and Persians, ii. 254.
Wilkinson, Sir Gardner, his work on Egypt, ii. 124, *note*.
Windows not found in Assyrian buildings, ii. 205.
Wine drunk at public festivals, ii. 312.
Wine-skins in bas-reliefs, i. 64.
Women represented in bas-reliefs, i. 275. Present at public festivals, ii. 193, 312.
Wood, beam of, discovered, ii. 36.

X.

Xanthus, people of, burn their city, ii. 173, *note*. Marble from, 226. * Their Assyrian character, 229.

Y.

Yakoub Nais, i. 158.
Yezidia, visit to, i. 225. Persecution of the, 230. Their dances, 237. Their music, 242. Their doctrines, 245. Origin of their name, 247. Their reverence for the sun, 239, 248. Their names, 249. Orders of the priesthood, 249. Their language, 251. See Sinjar.

Z.

Zab, wicker bridge across the, i. 166.
Zaweetha, village of, i. 159.
Zodiac, signs of, on Assyrian monuments, ii. 330, and *note*.
Zoroaster, ii. 335, and *note*.

THE END.

